

**Please Note:**

195

In order to reduce our costs in producing these ZTS books, the foldout maps **have not** been inserted into the appropriate areas. These fold-outs all follow this note. Please insert these maps into the appropriate location designated by the **pink** slip sheet.

Thank you  
ZTS group & Print Shop

NYC

FAIRVIEW PA EAST

TO ROCHESTER ±

w/GENEVA

# ZTS MAP UPDATE

Rev. 12/13/95

|                   |                 |
|-------------------|-----------------|
| DATE: _____       | DIVISION: _____ |
| FROM: NAME: _____ | ZONE: _____     |
| TITLE: _____      | PAGE: _____     |
| DEPT.: _____      | PHONE: _____    |
| ADDRESS: _____    | FAX: _____      |

|                           |                            |
|---------------------------|----------------------------|
| TO: CONRAIL - Z T S DEPT. | PHONE - 8-444-6056 / 6820  |
| 15 SUMMIT PARK DRIVE      | BELL - 412-747-6056 / 6820 |
| RIDC PARK WEST            | FAX - 8-444-6553           |
| PITTSBURGH, PA 15275      | BELL - 412-747-6553        |

SHOW ALL PERTINENT TRACK NUMBERS, PATRON NAMES, SPOTS, ETC.  
INDICATE WITHIN  (A) - ADD / (D) - DELETE / (C) - CHANGE

|                          |       |
|--------------------------|-------|
| <input type="checkbox"/> | _____ |
| <input type="checkbox"/> | _____ |
| <input type="checkbox"/> | _____ |
| <input type="checkbox"/> | _____ |
| <input type="checkbox"/> | _____ |
| <input type="checkbox"/> | _____ |
| <input type="checkbox"/> | _____ |
| <input type="checkbox"/> | _____ |
| <input type="checkbox"/> | _____ |
| <input type="checkbox"/> | _____ |
| <input type="checkbox"/> | _____ |
| <input type="checkbox"/> | _____ |
| <input type="checkbox"/> | _____ |
| <input type="checkbox"/> | _____ |
| <input type="checkbox"/> | _____ |

PLEASE MARK ALL CHANGES CLEARLY IN RED IF MAILING OR "X" OUT IF FAXING.  
ATTACH A COPY OF COVER SHEET AND CORRESPONDING MAP INDICATING AS  
ACCURATELY AS POSSIBLE ALL ADDITIONS / DELETIONS / CHANGES TO BE MADE.

## **INSTRUCTIONS - ZTS MAP UPDATE FORM**

1. Print Date, Name, Department, Address and Phone and Fax number of individual furnishing update information. Forward to the Customer Service ZTS Office in Pittsburgh as indicated on the form.
2. Print Division, Zone and Page information for the specific map or maps which need updating. This information is contained within the legend of each map.
3. There are three (3) basic types of updates which occur:
  1. An ADDITION - EX: ( Add track and patron XYZ Chemical )
  2. A DELETION - EX: ( Delete crossover, or tracks as marked )
  3. A CHANGE - EX: ( Change ABC Lumber to Uptown Lumber )
4. Indicate inside the box the type of update needed ( A, B, C, ) and give a brief explanation of the update. List all track numbers, patron names, spots, and any other pertinent information you feel will be helpful in updating the map and will eliminate misinterpretation once the form is received in Pittsburgh. It is **NECESSARY** to attach a COPY of the map and cover sheet involved with all updated areas marked. Do not send the original copy from your book because we will not send the original back if we find there was no change on that map or cover sheet. If a track has been removed, mark the ENTIRE area of track removed ( in Red if mailing, or "X" out or "White Out" if sending by fax. )

# ALBANY DIVISION VOLUME 4 ZONES 1-9, & 26, 28

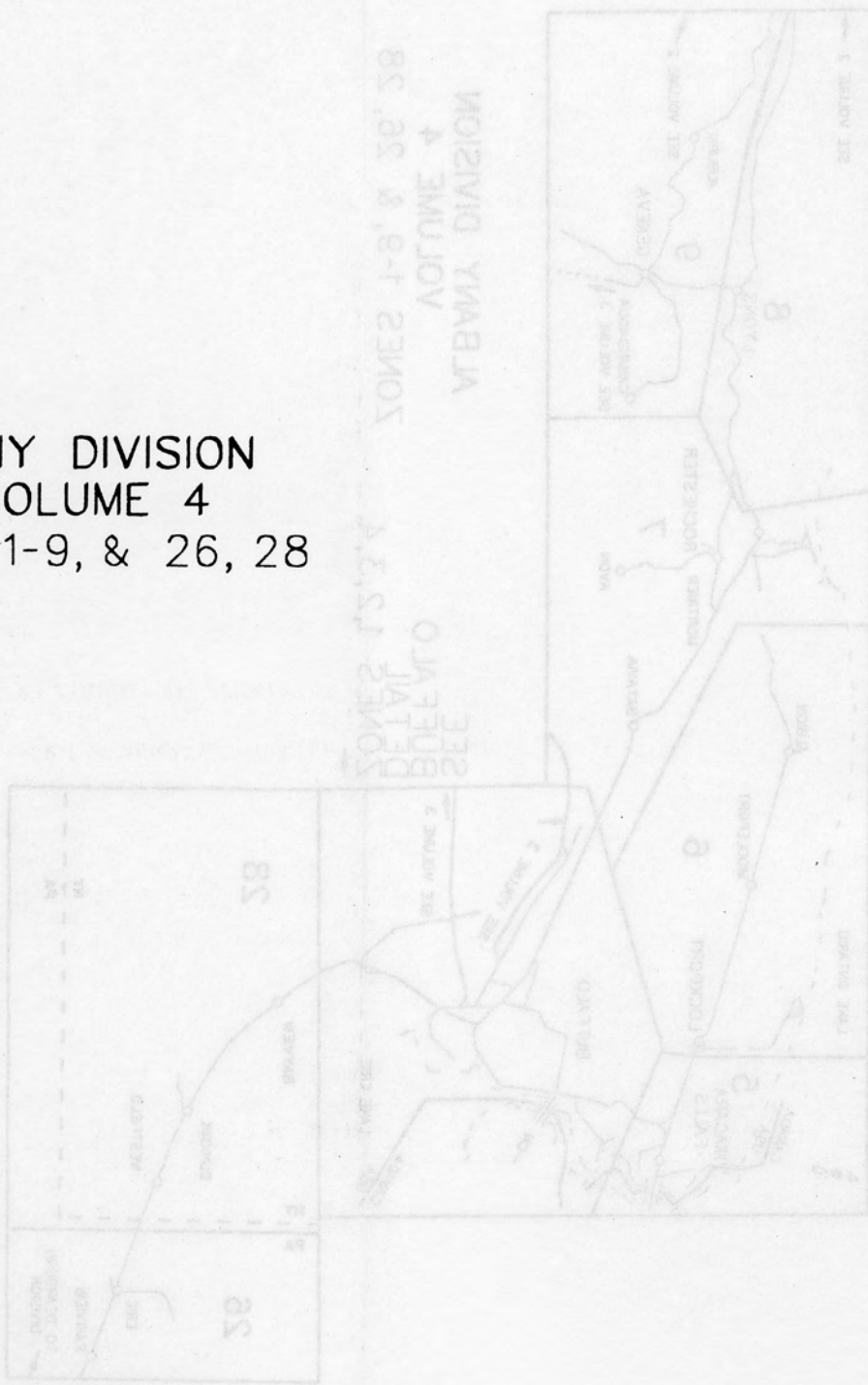

ALBANY DIVISION  
VOLUME 4  
ZONES 1-9, & 26, 28

ALBANY DIVISION  
VOLUME 4  
ZONES 1-9, & 26, 28

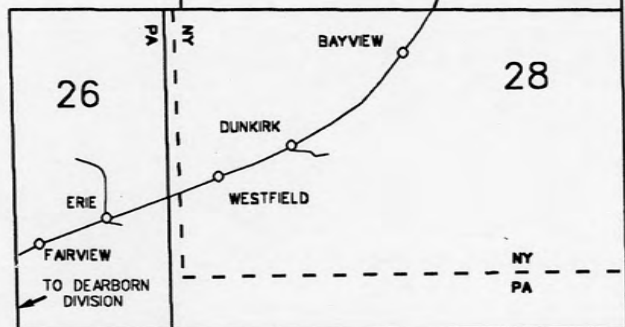
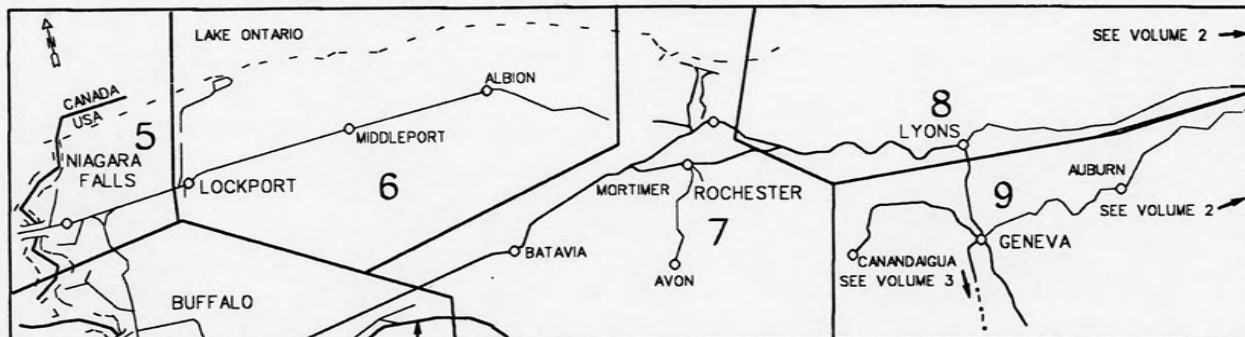

SEE  
BUFFALO  
DETAIL  
ZONES 1,2,3,4

ALBANY DIVISION  
VOLUME 4  
ZONES 1-9, & 26, 28

ALBANY DIVISION  
VOLUME 4  
ZONES 1-9, & 26, 28

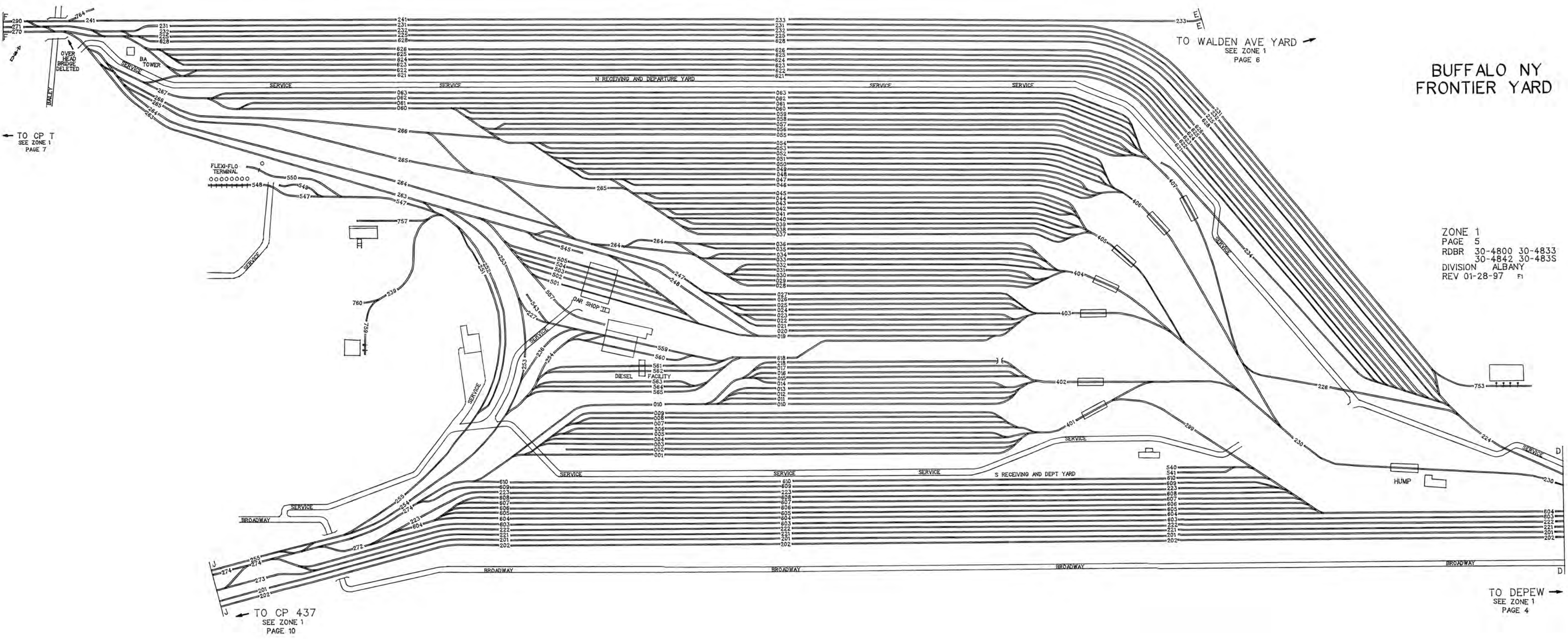

**BUFFALO NY  
FRONTIER YARD**

TO WALDEN AVE YARD  
SEE ZONE 1  
PAGE 6

TO CP T  
SEE ZONE 1  
PAGE 7

ZONE 1  
PAGE 5  
RDBR 30-4800 30-4833  
30-4842 30-4835  
DIVISION ALBANY  
REV 01-28-97 F1

FLEXI-FLO  
TERMINAL  
○○○○○○○○  
+++++ 548

BROADWAY

TO CP 437  
SEE ZONE 1  
PAGE 10

TO DEPEW  
SEE ZONE 1  
PAGE 4

BROADWAY

BROADWAY

BROADWAY

BROADWAY

D

D

D

# BUFFALO NY

ZONE 1  
PAGE 13  
RDBR 30-6401

DIVISION ALBANY  
REV 03-26-96

# BUFFALO NY

TO BISON  
RUNNING TRACK  
SEE ZONE 1  
PAGE 12

← TO ERIE  
SEE ZONE 2  
PAGE 8

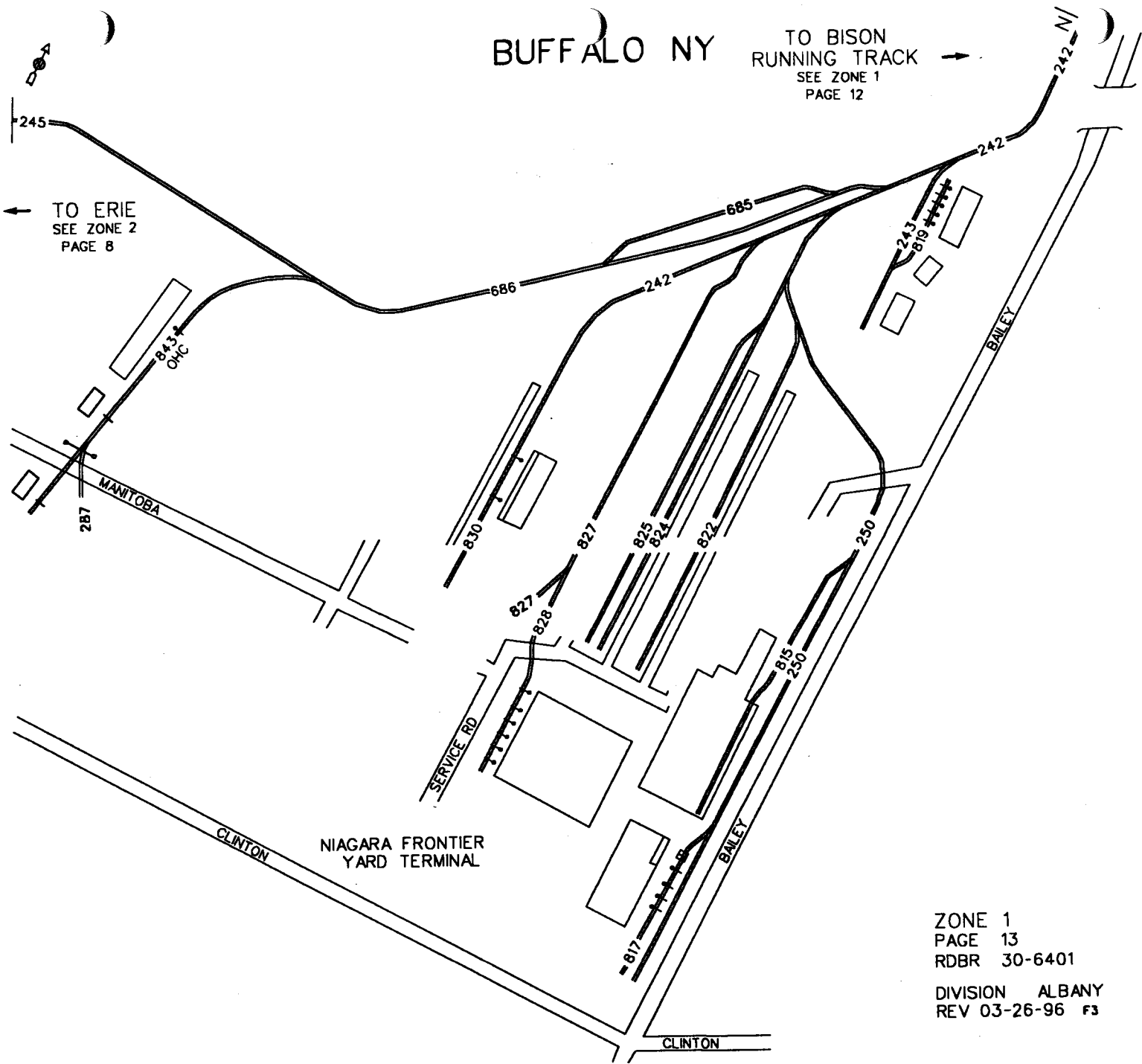

NIAGARA FRONTIER  
YARD TERMINAL

ZONE 1  
PAGE 13  
RDBR 30-6401

DIVISION ALBANY  
REV 03-26-96 F3



BUFFALO NY

ZONE 2  
PAGE 14  
RDBR 30-6467

DIVISION ALBANY  
REV 03-19-96

# BUFFALO NY

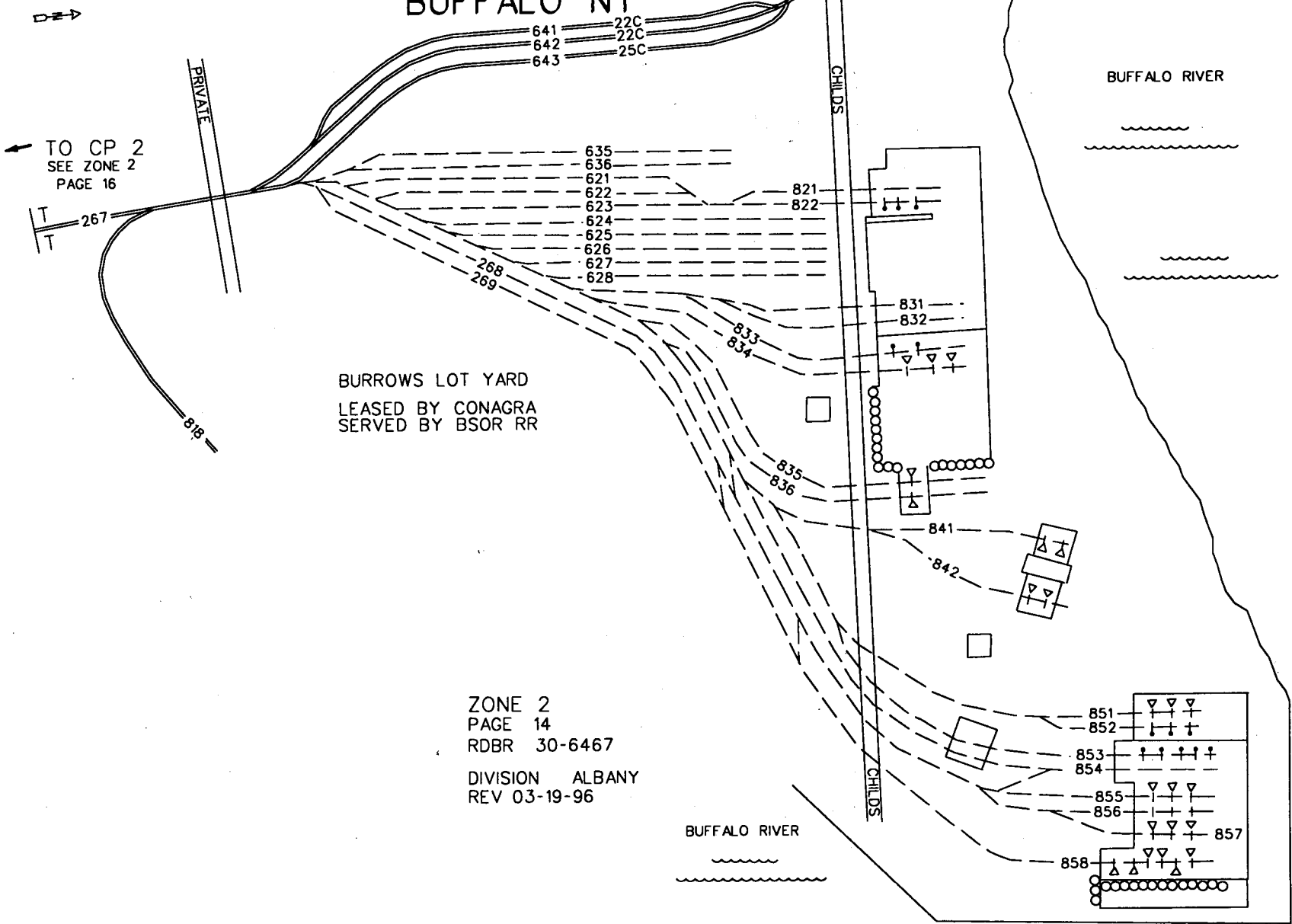

TO CP 2  
SEE ZONE 2  
PAGE 16

BURROWS LOT YARD  
LEASED BY CONAGRA  
SERVED BY BSOR RR

ZONE 2  
PAGE 14  
RDBR 30-6467  
DIVISION ALBANY  
REV 03-19-96

BUFFALO RIVER

BUFFALO RIVER

LACKAWANNA NY  
NORTH END  
(SENECA YARD)

ZONE 3  
PAGE 7  
RDBR 30-4800  
30-4853  
DIVISION ALBANY  
REV 03-19-96

LACKAWANNA NY  
(SENECA YARD)

781  
782  
BUFFALO NY

NY RTE 5 BUFFALO SKYWAY

Not All  
Tracks Shown

ZONE 3  
PAGE 7  
RDBR 30-4800 30-0616  
30-4841  
DIVISION ALBANY  
REV 03-19-96

TO SENECA CLASS YARD  
SEE ZONE 3  
PAGE 6

PENN YARD

TO CP 2  
SEE ZONE 2  
PAGE 11

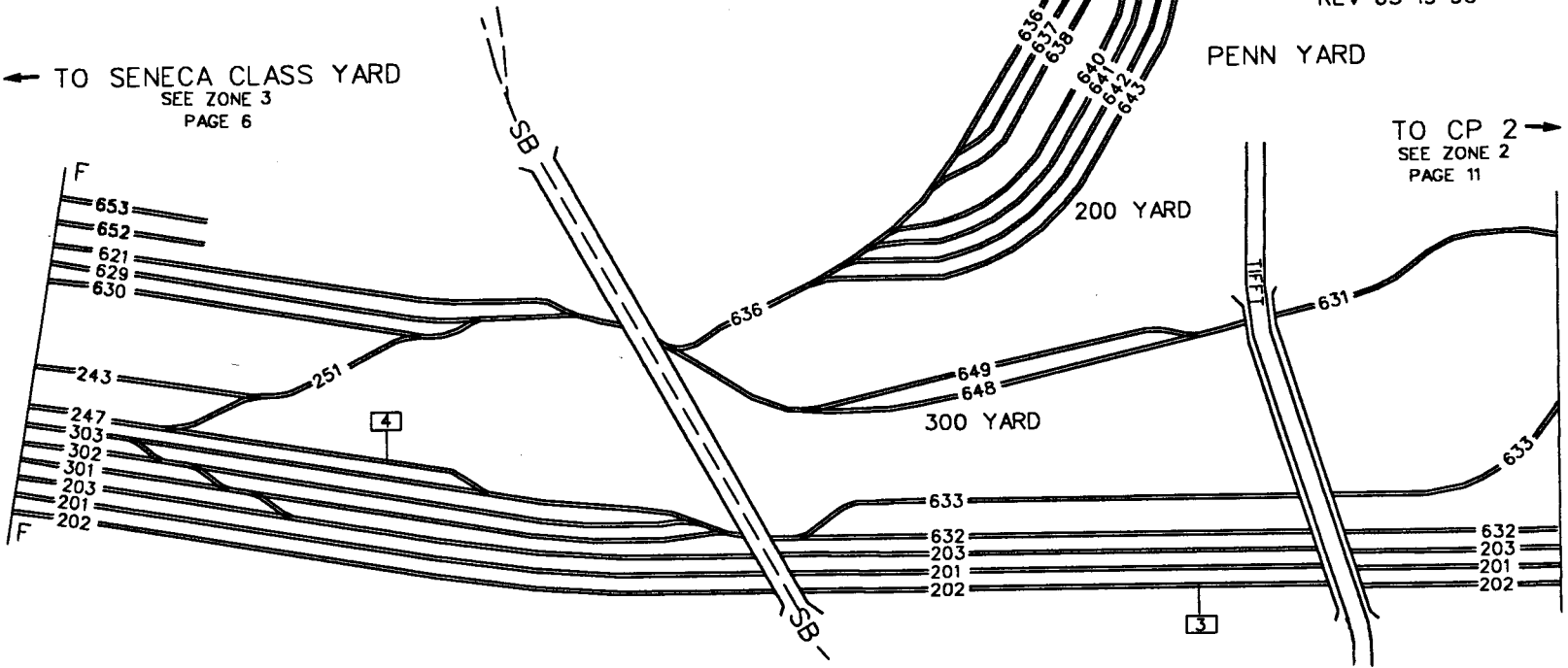

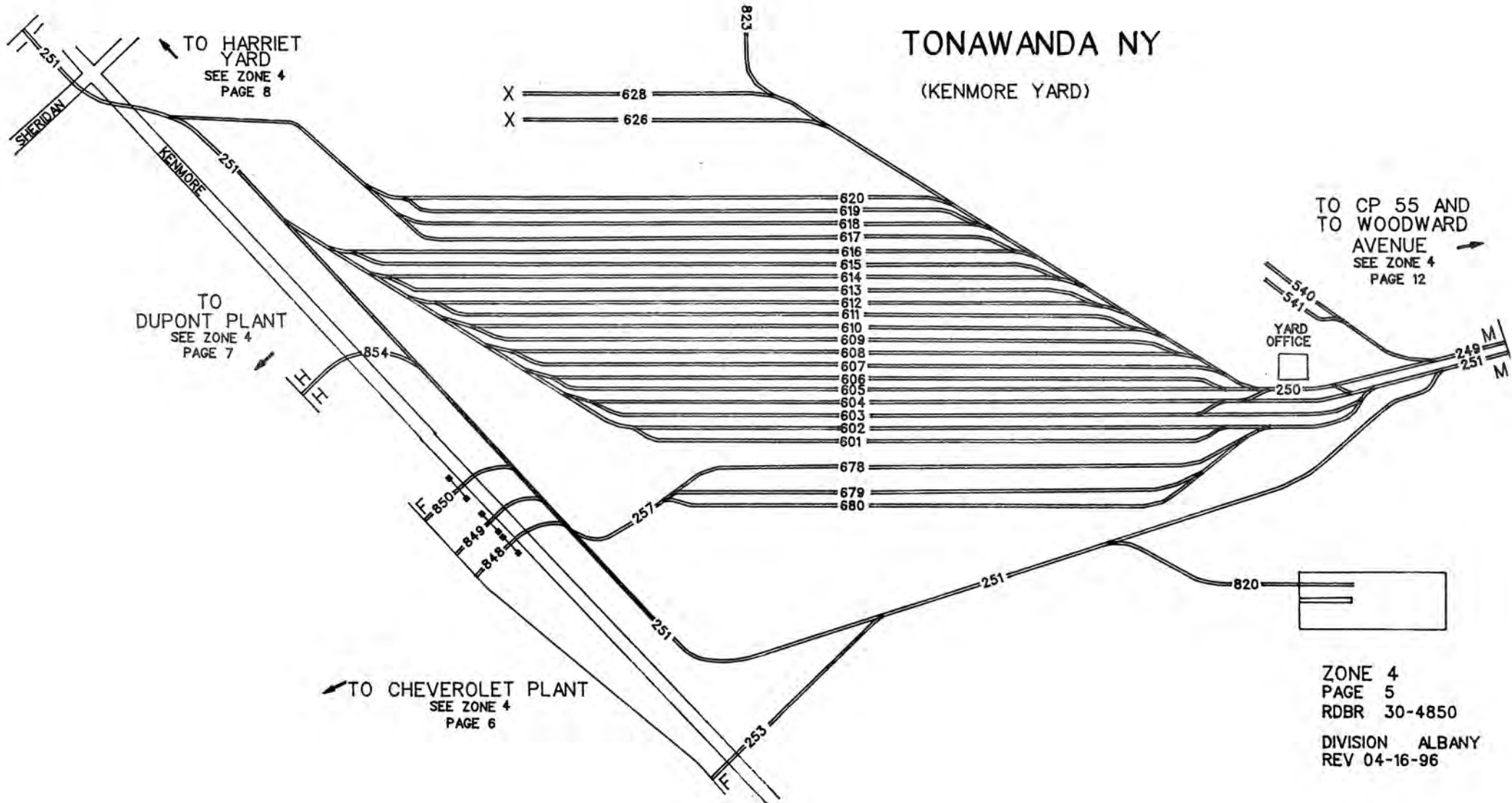

TONAWANDA NY  
(KENMORE YARD)

TO HARRIET YARD  
SEE ZONE 4  
PAGE 8

TO DUPONT PLANT  
SEE ZONE 4  
PAGE 7

TO CHEVEROLET PLANT  
SEE ZONE 4  
PAGE 6

TO CP 55 AND  
TO WOODWARD AVENUE  
SEE ZONE 4  
PAGE 12

YARD OFFICE

ZONE 4  
PAGE 5  
RDBR 30-4850  
DIVISION ALBANY  
REV 04-16-96

X ——— 628  
X ——— 626

- 620
- 619
- 618
- 617
- 616
- 615
- 614
- 613
- 612
- 611
- 610
- 609
- 608
- 607
- 606
- 605
- 604
- 603
- 602
- 601

- 678
- 679
- 680

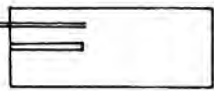

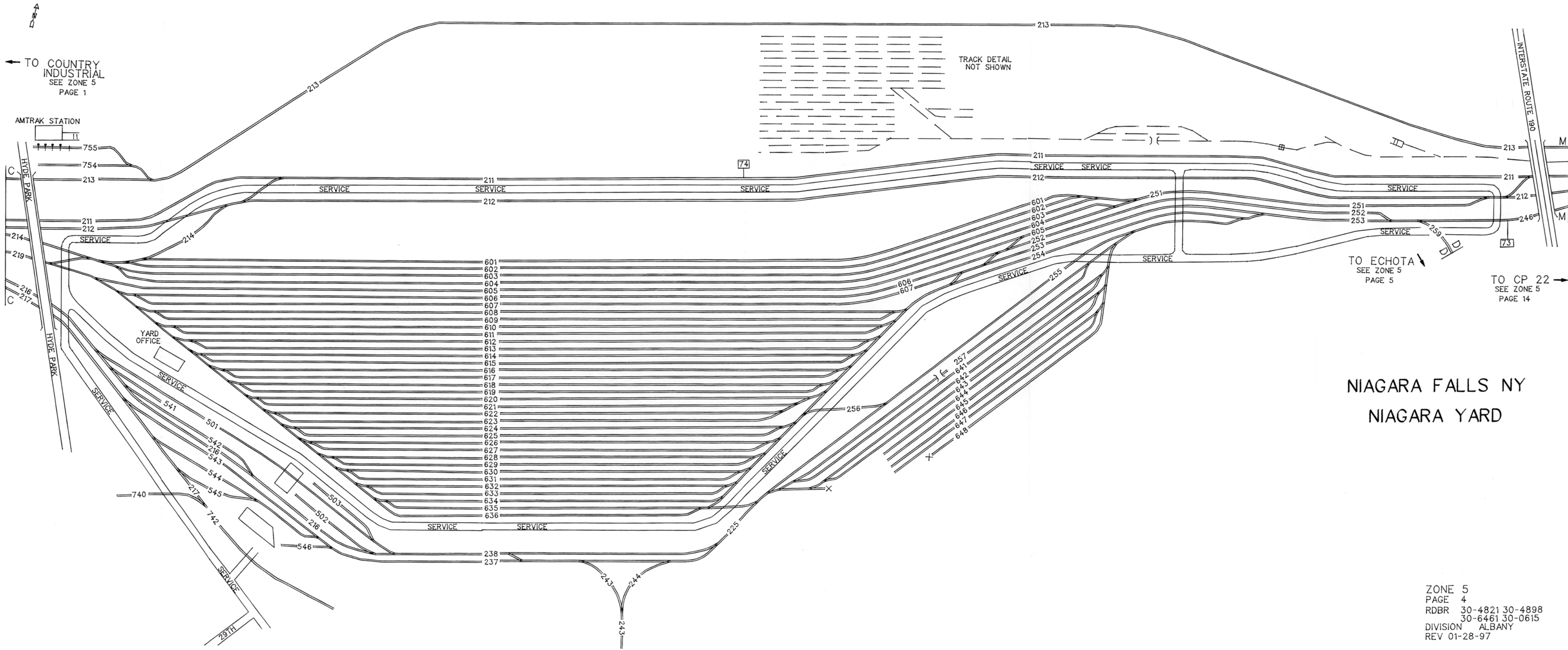

NIAGARA FALLS NY  
NIAGARA YARD

ZONE 5  
PAGE 4  
RDBR 30-4821 30-4898  
30-6461 30-0615  
DIVISION ALBANY  
REV 01-28-97

**INSTRUCTIONS**

ENCLOSED IS YOUR NEW **ALBANY VOL 4**  
ZTS BOOK. THIS REPLACES YOUR OLD  
**ALBANY VOL 4** BOOK IN ITS ENTIRETY.

THE INFORMATION USED TO UPDATE THIS  
BOOK WAS GATHERED FROM VARIOUS SOURCES:  
COC'S, DIVISION PERSONNEL, ENGINEERING,  
AND FROM CUSTOMER THEMSELVES THROUGH  
THE SWITCH MAINTENANCE PROCESS. ALL OF  
THE SOURCES HAVE BEEN AND WILL CONTINUE  
TO BE, VERY VALUABLE TO OUR CONTINUOUS  
COMMITMENT OF PROVIDING QUALITY INFORMATION.

THE MAPS AND REFERENCE PAGES ARE ONLY AS  
GOOD AS THE INFORMATION WE RECEIVE.

M.R. TERRILL  
J. KINNEY

ZTS MAPS  
15 SUMMIT PARK DRIVE  
RIDC PARK WEST  
PITTSBURGH, PA 15275

**ATTENTION**

REQUEST FOR " ZTS " BOOKS WILL NOW  
BE MADE TO YOUR DIVISION HEAD QUARTERS.  
SEE THE BACK OF THIS PAGE FOR A LIST.

PHONE 8 - 444 - 6056 OR 6820  
BELL 412 - 893 - 6056 / 6820

FAX 8 - 444 - 6553  
BELL - FAX 412 - 893 - 6553

## **Albany**

Dave Stevenson  
Manager Customer Service  
One Bell Crossing Rd.  
Selkirk, NY 12158  
8-245-6266

## **Dearborn**

J. L. Taylor  
17301 Michigan Ave.  
Dearborn, MI 48126  
8-520-5001

## **Indianapolis**

E. A. Strauss  
Division Manager Customer Service  
31 E. Georgia St.  
Indianapolis, IN 46204  
8-531-4521

## **Philadelphia**

Brian Keller  
Manager Operating Rules  
1000 Howard Blvd.  
Mt. Laurel, NJ 08054-2355  
8-320-2355

## **Pittsburgh**

Dick Chambers  
Suite 108 Conrail Building  
425 Holiday Drive  
Pittsburgh, PA 15220  
8-444-7085

## **NCSC**

Mark Shebby  
Director Revenue Protection  
15 Summit Park Drive  
RIDC Park West  
Pittsburgh, PA 15275  
8-444-6057





CONRAIL  
CUSTOMER SERVICE  
ZTS MAPS

ALBANY DIVISION

VOLUME 4

DATE OF ISSUE:

FEB 1997

# LEGEND

## DESCRIPTION OF SYMBOLS

CONRAIL TRACK   
 (DOES NOT INDICATE OWNERSHIP)

CONRAIL TRACK  
 ANOTHER ZONE 

FORIEGN ROAD OR  
 PRIVATE INDUSTRY TRACK  
 ON WHICH CR DOES NOT SWITCH 

TRACK SPOT 

DOOR SPOT 

TANK CONNECTION 

PNEUMATIC TUBE CONNECTION 

LOADING SPOUT 

HOPPER UNLOADING PIT 

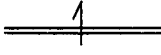
ONE SIDE UNLOAD SPOT 

ARROW INDICATES  
 NUMBERING OF SPOTS  
 ON DOUBLE  
 ENDED SIDETRACK 



CAR CAPACITY OF TRACK  
 KEEP IN MIND THAT CAPACITY CAN CHANGE  
 AS CARS GET LONGER, TRACKS SHORTER, ETC

OVERHEAD CRANE 

MILE POST MARKER 

DIVISION POST OR  
 DIVIDING POINT 

# LEGEND

(CONT)

GATE AT INDUSTRY

PRIVATE LOCK

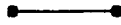

RAILROAD LOCK



BREAK (DISTANCE)

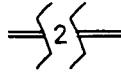

ROUND STRUCTURE

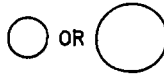

NORTH ARROW

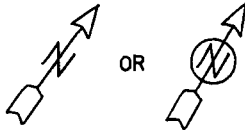

END OF TRACK



BRIDGES

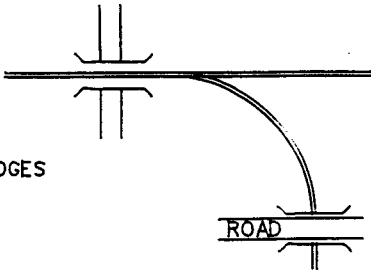

SCALE



RAMP

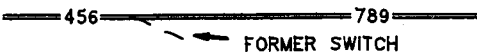
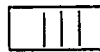

ABOUT TRACKS WITH MORE THAN 1 ZTS NUMBER THESE MULTIPLE NUMBERS RESULT WHEN A SWITCH OR DIVIDING POINT OF A DEFINITIVE PIECE OF TRACK HAS BEEN REMOVED. THESE DIFFERENT TRACK SEGMENTS ARE STILL IDENTIFIED AS SUCH IN OTHER DATA BASES SO ARE LEFT IN ZTS BOOK AS SUCH.

**ZTS  
TRACK NUMBERING SCHEME**

\*\*\*\*\*

**NUMBER  
SERIES**

**APPLIES TO**

---

- 001-199 - CLASSIFICATION TRACKS
  
- 200-299 - MAIN TRACKS
  - SIDINGS
  - SWITCHING LEADS
  - RAILROAD SCALE TRACKS
  
- 300-349 - RECEIVING TRACKS
  
- 350-399 - DEPARTURE TRACKS
  
- 400-499 - RESERVED FOR SPECIAL APPLICATIONS
  
- 500-527 - CAR REPAIR TRACKS
  - 528 - TRIMS INBOUND SHOP
  - 529 - TRIMS OUTBOUND SHOP
  
- 530-539 - CLEAN OUT TRACKS
  
- 540-597 - INTERMODAL
  - FLEXI-FLOW
  - AUTO TERMINAL
  - ENGINE FACILITIES
  - OTHER COMPANY USE TRACKS FOR
  - LOADING & UNLOADING
  - 598 - TICS INBOUND REPORTING
  - 599 - TICS OUTBOUND REPORTING
  
- 600-696 - OUTLYING YARD TRACKS
  - INTERCHANGE TRACKS
  
- 697-699 - DATA EXCHANGE TRACKS
  
- 700-997 - INDUSTRY TRACKS
  
- 998-999 - RESERVED FOR SPECIAL APPLICATIONS

\*\*\*\*\*

# ZONE TRACK SPOT DESCRIPTION

\*\*\*\*\*

**ZONE:** Each Division is divided into a series of Zones, each individually numbered.

**TRACK:** Each Track in a Zone will have a unique number assigned to it.  
(Note - There may be more than one industry on any given track).

**SPOT:** Will further define the location a car is to be placed. (If more than one patron is located on any given track, the Spot will further define the patron's exact location). Spot number 99 99 indicates patron has no designated Spot locations on that track.

### PATRON DESCRIPTION

04 | 829 | 01 | 01 | ABC COMPANY

Indicates patron is assigned one spot delivery.

04 | 829 | 02 | 03 | XYZ COMPANY

Indicates patron is assigned spots two & three for delivery.

04 | 829 | 04 | 09 | GENERIC INC.

Indicates patron is assigned spots four through nine for delivery.

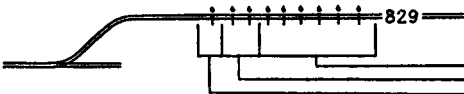

**NOTE:** While all above patrons are on one track, they are separated by unique spot numbers.

\*\*\*\*\*



ALBANY DIVISION - CONVERSION OF ZONES

Volume 1 -(Former New England)

| NEW  | OLD   | ZONE NAME            |
|------|-------|----------------------|
| ZONE | ZONE  |                      |
| 70   | 5 & 6 | BOSTON               |
| 71   | 7     | MIDDLEBORO           |
| 72   | 6     | READVILLE            |
| 73   | 3 & 4 | FRAMINGHAM\WORCESTER |
| 74   | 1     | SPRINGFIELD          |
| 75   | 8     | HARTFORD             |
| 76   | 11    | CEDAR HILL - 2       |
| 77   | 10    | CEDAR HILL - 1       |
| 79   | 2     | PITTSFIELD           |

VOLUME 2 -(Former Mohawk Hudson)

| NEW         | OLD         |                     |
|-------------|-------------|---------------------|
| <u>ZONE</u> | <u>ZONE</u> | <u>ZONE NAME</u>    |
| 80          | 1           | Selkirk             |
| 81          | 2 & 3       | Poughkeepsie/Croton |
| 82          | 4           | Metropolitan        |
| 83          | 5 & 6       | Mohawk              |
| 84          | 6 & 7       | Dewitt/Utica        |
| 85          | 8           | Syracuse/Solvay     |
| 86          | 9           | Fulton              |
| 87          | 10          | Watertown           |
| 88          | 11 & 12     | Carthage/Gouverneur |
| 89          | 13          | Massena             |
| 90          | 14          | Montreal            |

VOLUME 3 - (Former Southern Tier)

| NEW         | OLD         |                  |
|-------------|-------------|------------------|
| <u>ZONE</u> | <u>ZONE</u> | <u>ZONE NAME</u> |
| 91          | 1           | Elmira           |
| 92          | 2           | Binghamton       |
| 93          | 3           | Campbell Hall    |
| 94          | 4           | Corning          |
| 95          | 5           | Himrod Jct.      |
| 96          | 6           | Olean            |
| 97          | 7           | Jamestown        |
| 98          | 8           | Ithaca           |
| 99          | 85          | Corry            |

\* VOLUME 4 - (Former Buffalo)

Zones 1 thru 9

\* NO CONVERSION NECESSARY

# **ALBANY DIVISION**

**Former Pittsburgh Division - Conversion of Zones**

**Volume 4 - (Former Cleveland)**

| <b><u>NEW<br/>ZONES</u></b> | <b><u>ZONES</u></b> | <b><u>ZONE NAME</u></b> |
|-----------------------------|---------------------|-------------------------|
| 26                          | 6 & 7               | Painesville/Erie        |
| 28                          | 81                  | Dunkirk                 |



## MAP INDEX

| CITY               | ST | ZONE | PAGE  |
|--------------------|----|------|-------|
| Abby Yard          | NY | 2    | 9     |
| Angola             | NY | 28   | 9     |
| Batavia            | NY | 7    | 1-3   |
| Batavia Yard       | NY | 7    | 2     |
| Bayview            | NY | 28   | 9     |
| Bayview            | NY | 3    | 5     |
| Belle Isle         | NY | 8    | 11    |
| Bergen             | NY | 7    | 4     |
| Black Rock         | NY | 4    | 17    |
| Blasdell           | NY | 3    | 5     |
| Bowmansville       | NY | 1    | 3     |
| Brocton            | NY | 28   | 2     |
| Buffalo            | NY | 1    | 7-13  |
| Buffalo            | NY | 4    | 12-17 |
| Buffalo            | NY | 3    | 7     |
| Buffalo            | NY | 1    | 5     |
| Buffalo            | NY | 3    | 4     |
| Buffalo            | NY | 2    | 1-16  |
| Buffalo Avenue     | NY | 5    | 12    |
| Buffalo Jct. Yard  | NY | 2    | 9     |
| Burrows Lot Yard   | NY | 2    | 14    |
| Cambria            | NY | 5    | 17    |
| Charlotte          | NY | 7    | 16-17 |
| Charlotte Yard     | NY | 7    | 17    |
| Cheektowaga        | NY | 1    | 14    |
| Cheektowaga        | NY | 1    | 6     |
| Cheektowaga        | NY | 1    | 3-4   |
| Chili              | NY | 7    | 9     |
| Chili              | NY | 7    | 5     |
| Chili Center       | NY | 7    | 5     |
| Clyde              | NY | 8    | 6     |
| Coldwater          | NY | 7    | 9     |
| Corfu              | NY | 7    | 1     |
| Country Industrial | NY | 5    | 1-3   |
| Crittenden         | NY | 7    | 1     |
| Depew              | NY | 1    | 1-2   |
| Dunkirk            | NY | 28   | 3-7   |
| Dunkirk Yard       | NY | 28   | 7     |
| Dunkirk Yard       | NY | 28   | 4     |
| East Rochester     | NY | 8    | 1     |
| East Yard          | PA | 26   | 12    |
| East Yard          | PA | 26   | 9     |
| Echota             | NY | 5    | 7     |
| Elm                | PA | 26   | 6     |
| Erie               | PA | 26   | 1-12  |
| Fairport           | NY | 8    | 1     |
| Fairport           | NY | 7    | 8     |
| Fairview           | PA | 26   | 1     |
| Foote Yard         | NY | 5    | 5     |

## MAP INDEX

| CITY                | ST | ZONE | PAGE  |
|---------------------|----|------|-------|
| Foxridge            | NY | 8    | 8     |
| Fredonia            | NY | 28   | 6     |
| Frontier Yard       | NY | 1    | 4-5   |
| Gardenville         | NY | 3    | 3     |
| Gates               | NY | 7    | 10    |
| Genesee Junction    | NY | 7    | 5-6   |
| Genesee Junction Yd | NY | 7    | 5     |
| Geneva              | NY | 9    | 1-3   |
| Goodman St. Yard    | NY | 7    | 19    |
| Hamburg Street Yard | NY | 2    | 4     |
| Harbor Creek        | PA | 26   | 13    |
| Harriet             | NY | 4    | 11    |
| Harriet             | NY | 4    | 8     |
| Harriet Yard        | NY | 4    | 10    |
| Henrietta           | NY | 7    | 7-8   |
| Huntley Yard        | NY | 4    | 9     |
| Jordan              | NY | 8    | 10    |
| Katherine St Lead   | NY | 2    | 5     |
| Kenmore             | NY | 4    | 12-13 |
| Kenmore Yard        | NY | 4    | 5     |
| Lackawanna          | NY | 3    | 5-7   |
| Lancaster           | NY | 1    | 1     |
| Lockport            | NY | 5    | 17-18 |
| Lockport            | NY | 6    | 1     |
| Lockport            | NY | 6    | 3     |
| Lockport Yard       | NY | 6    | 3     |
| Lyons               | NY | 8    | 5-6   |
| Lyons Yard          | NY | 8    | 5     |
| Macedon             | NY | 8    | 3     |
| Martinsville        | NY | 4    | 2     |
| Mortimer            | NY | 7    | 6     |
| Newark              | NY | 8    | 4     |
| NFFT                | NY | 1    | 13    |
| Niagara Falls       | NY | 5    | 1-14  |
| Niagara Yard        | NY | 5    | 4     |
| North East          | PA | 26   | 14-15 |
| North Evans         | NY | 28   | 9     |
| North Macedon       | NY | 8    | 3     |
| North Port Byron    | NY | 8    | 9     |
| North Tonawanda     | NY | 4    | 1     |
| North Tonawanda     | NY | 4    | 3     |
| North Weedsport     | NY | 8    | 9     |
| North Yard          | NY | 1    | 12    |
| OD Yard             | PA | 26   | 5     |
| Ohio St. Middle Yd  | NY | 2    | 12    |
| Ohio Street         | NY | 2    | 13    |
| Ohio Street Yard    | NY | 2    | 15    |
| Otis Yard           | NY | 7    | 14    |
| Palmyra             | NY | 8    | 3     |

## MAP INDEX

| CITY               | ST | ZONE | PAGE  |
|--------------------|----|------|-------|
| Penn Yard          | NY | 3    | 7     |
| Pittsford          | NY | 7    | 8     |
| Ripley             | NY | 28   | 1     |
| Riverside Track    | NY | 5    | 10-11 |
| Rochester          | NY | 7    | 18-20 |
| Rochester          | NY | 7    | 11-15 |
| Sanborn            | NY | 5    | 15    |
| Savannah           | NY | 8    | 7     |
| Scott Street       | NY | 2    | 3     |
| Seneca Yard        | NY | 3    | 6-7   |
| Silver Creek       | NY | 28   | 8     |
| SK Yard            | NY | 1    | 12    |
| SK Yard (DH)       | NY | 2    | 8     |
| Sloan              | NY | 1    | 14    |
| Somerset           | NY | 6    | 2     |
| South Byron        | NY | 7    | 4     |
| Spencerport        | NY | 7    | 13    |
| Stock Yard         | NY | 1    | 11    |
| Thompson           | NY | 9    | 1     |
| Tonawanda          | NY | 4    | 3-11  |
| Walden Avenue Yard | NY | 1    | 6     |
| Walmore            | NY | 5    | 15-16 |
| Warners            | NY | 8    | 11    |
| Wayneport          | NY | 8    | 2     |
| Wesleyville        | PA | 26   | 13    |
| West Seneca        | NY | 3    | 1-3   |
| Westfield          | NY | 28   | 1-2   |
| Wheatfield         | NY | 5    | 16    |
| Windsor Beach      | NY | 7    | 16    |



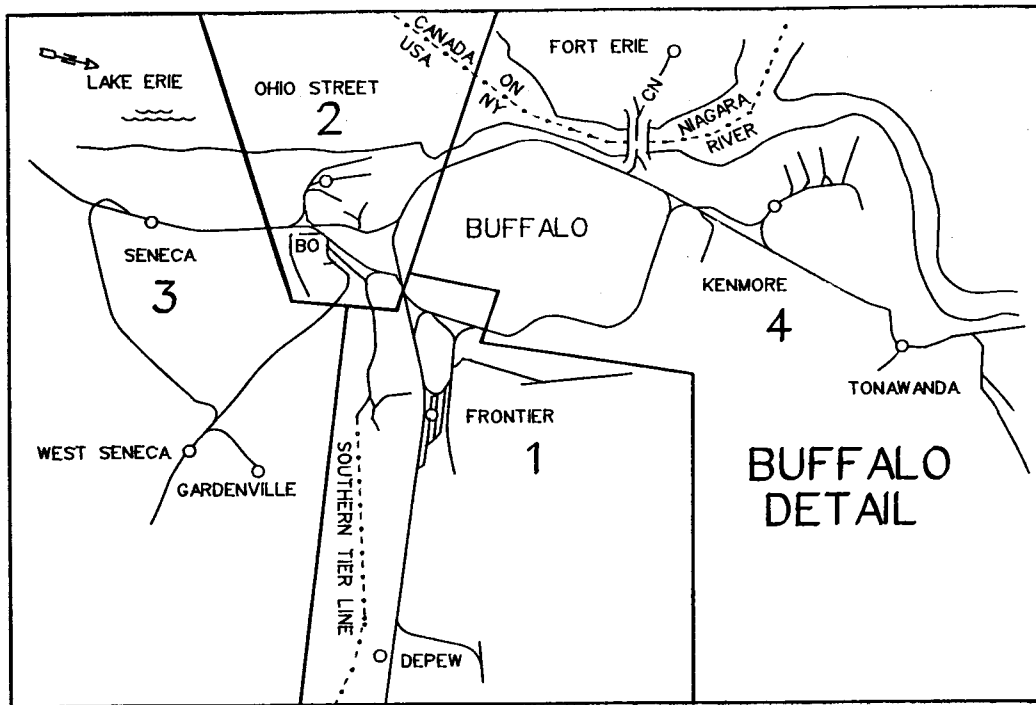



# FRONTIER ZONE 1

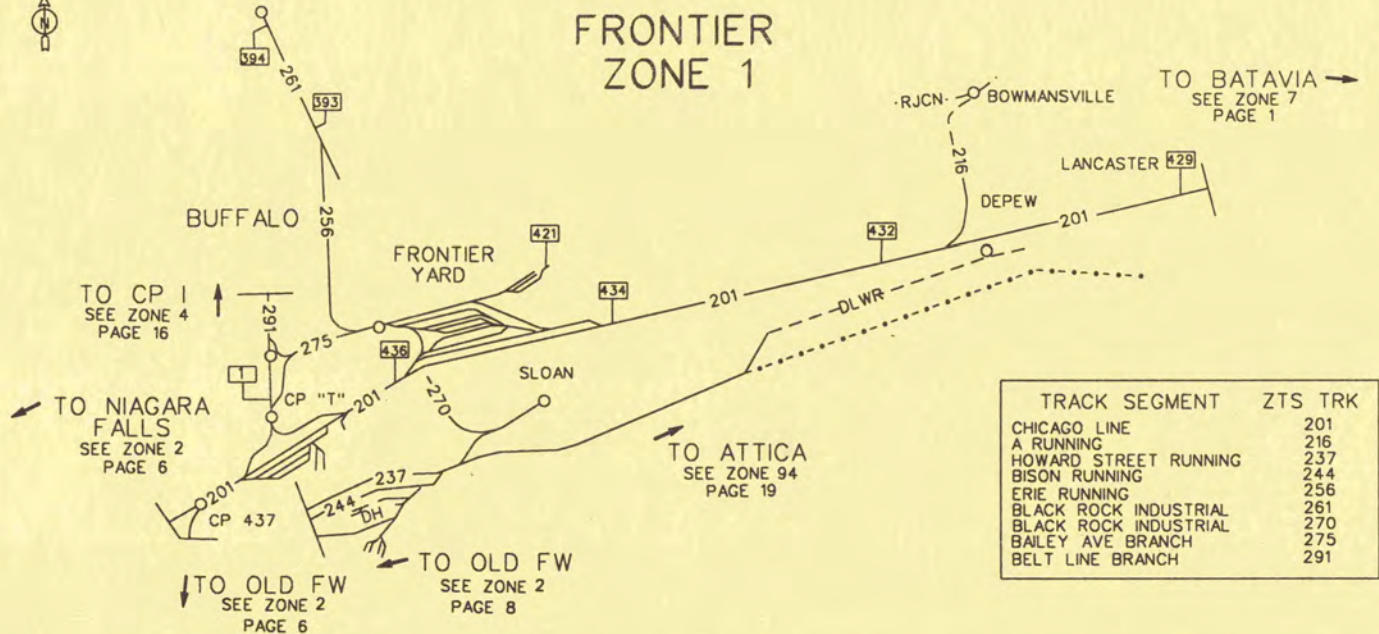

| TRACK SEGMENT         | ZTS TRK |
|-----------------------|---------|
| CHICAGO LINE          | 201     |
| A RUNNING             | 216     |
| HOWARD STREET RUNNING | 237     |
| BISON RUNNING         | 244     |
| ERIE RUNNING          | 256     |
| BLACK ROCK INDUSTRIAL | 261     |
| BLACK ROCK INDUSTRIAL | 270     |
| BAILEY AVE BRANCH     | 275     |
| BELT LINE BRANCH      | 291     |

ZONE 1

Rev 12/20/96

PAGE 1

|   |     |    |    |                            |
|---|-----|----|----|----------------------------|
| 1 | 201 | 00 | 00 | Chicago - Line - TK.#1     |
| 1 | 202 | 00 | 00 | Chicago - Line - Tk.#2     |
| 1 | 203 | 00 | 00 | Chicago - Line - Tk.#3     |
| 1 | 204 | 00 | 00 | Chicago - Line - Tk.#4     |
| 1 | 213 | 00 | 00 | Ind. Lead - Tk.            |
| 1 | 214 | 00 | 00 | Runaround                  |
| 1 | 701 | 01 | 02 | Weyerhaeuser               |
| 1 | 701 | 99 | 99 | Babcock Lumber             |
| 1 | 702 | 01 | 03 | Weyerhaeuser Lumber        |
| 1 | 703 | 01 | 01 | Henry & Henry              |
| 1 | 709 | 01 | 03 | Domtar Ind.                |
| 1 | 711 | 97 | 97 | Depew - (Team Tk.)         |
| 1 | 713 | 99 | 99 | Eighty Four Lumber         |
| 1 | 715 | 01 | 01 | Dowell                     |
| 1 | 717 | 99 | 99 | Scrantons Thruway Builders |
| 1 | 719 | 01 | 01 | Vacant                     |



# DEPEW NY

# LANCASTER NY

ZONE 1  
 PAGE 1  
 RDBR 30-4800

DIVISION ALBANY  
 REV 03-15-96

TO BATAVIA →  
 SEE ZONE 7  
 PAGE 1

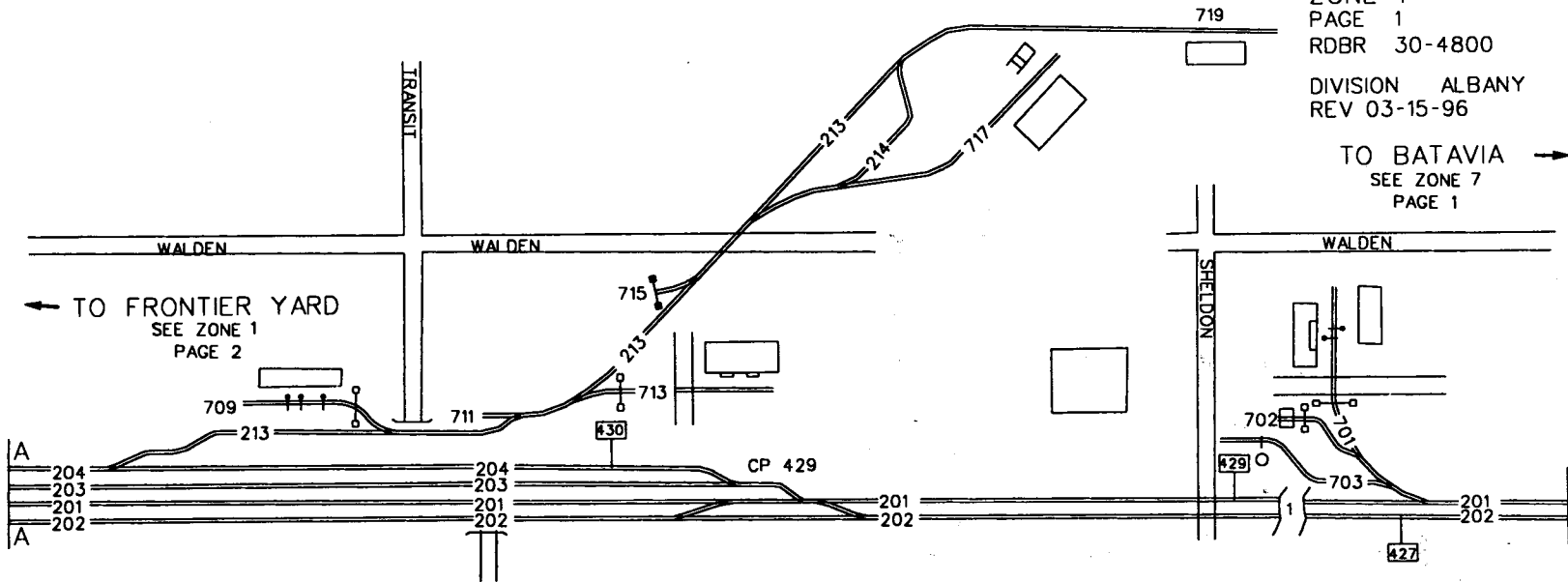



ZONE 1

Rev 12/9/96

PAGE 2

|   |     |    |    |                               |
|---|-----|----|----|-------------------------------|
| 1 | 201 | 00 | 00 | Chicago - Line - Tk.#1        |
| 1 | 202 | 00 | 00 | Chicago - Line - Tk.#2        |
| 1 | 203 | 00 | 00 | Chicago - Line - Tk.#3        |
| 1 | 204 | 00 | 00 | Chicago - Line - Tk.#4        |
| 1 | 216 | 00 | 00 | Industrial - Tk.(A)           |
| 1 | 222 | 00 | 00 | Running - Tk.South-2W         |
| 1 | 224 | 00 | 00 | Eastbound - Runner            |
| 1 | 721 | 99 | 99 | G.M. Plant                    |
| 1 | 723 | 01 | 04 | Georgia Pacific               |
| 1 | 725 | 01 | 03 | Buff Tech                     |
| 1 | 731 | 99 | 99 | Quebecor Printing Tk #1       |
| 1 | 732 | 99 | 99 | Quebecor Printing Tk.#2       |
| 1 | 735 | 99 | 99 | Quebecor Printing Tk.#5       |
| 1 | 736 | 99 | 99 | Quebecor Printing Fence Tk.#6 |
| 1 | 746 | 99 | 99 | Bestway                       |



DEPEW NY TO WALDEN  
 RUNNING TRACK  
 SEE ZONE 1  
 PAGE 3

TO FRONTIER YARD  
 SEE ZONE 1  
 PAGE 4

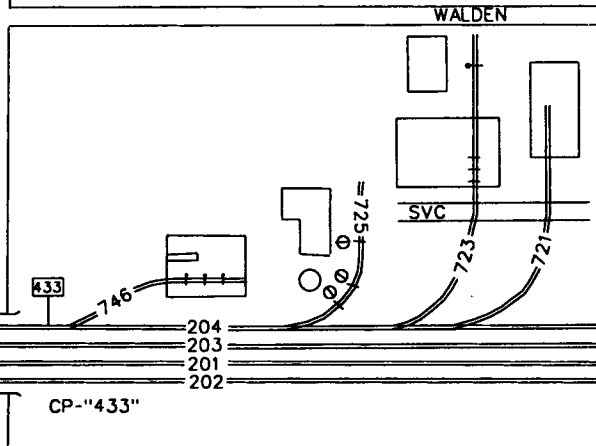
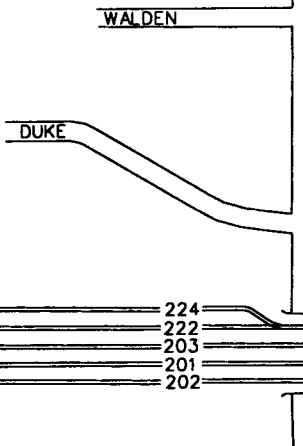
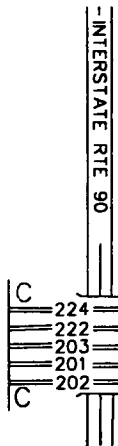
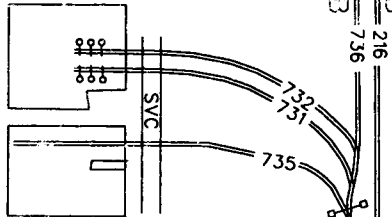

ZONE 1  
 PAGE 2  
 RDBR 30-4800  
 30-4847  
 DIVISION ALBANY  
 REV 02-01-94



STATION

431

TO BATAVIA  
 SEE ZONE 1  
 PAGE 1



**ZONE 1**

**Rev 12/17/96**

**PAGE 3**

1 216 00 00 Industrial - Tk.(A)  
1 601 00 00 (RJCN) - I/C Tk.  
1 727 01 06 Sonwill Dist. Center - Tk.  
1 736 99 99 Quebecor Printing Fence Tk.#6



CHEEKTOWAGA NY

BOWMANSVILLE NY

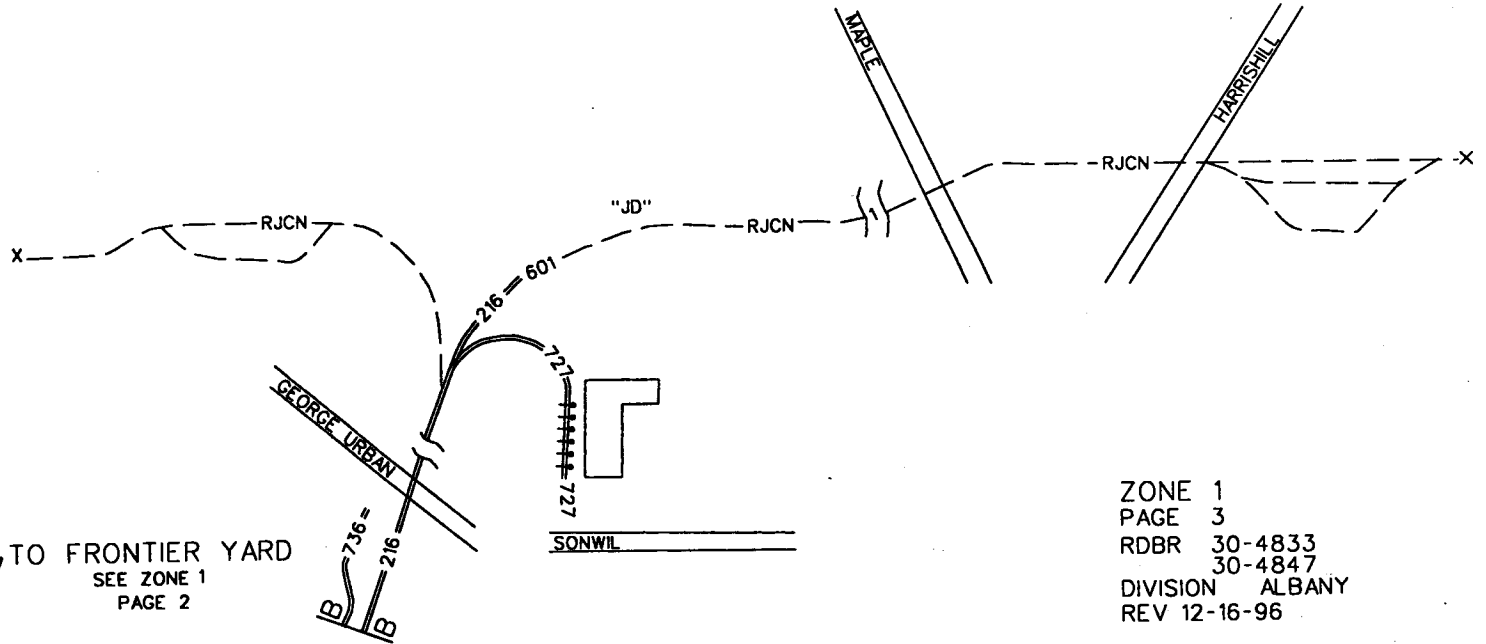

TO FRONTIER YARD  
 SEE ZONE 1  
 PAGE 2

ZONE 1  
 PAGE 3  
 RDBR 30-4833  
 30-4847  
 DIVISION ALBANY  
 REV 12-16-96

ZONE 1

Rev 12/9/96

PAGE 4

|   |     |    |    |                              |
|---|-----|----|----|------------------------------|
| 1 | 201 | 00 | 00 | Chicago - Line - Tk.#1       |
| 1 | 202 | 00 | 00 | Chicago - Line - Tk.#2       |
| 1 | 203 | 00 | 00 | Chicago - Line - Tk.#3       |
| 1 | 221 | 00 | 00 | Running - Tk.South-1W        |
| 1 | 222 | 00 | 00 | Running - Tk.South-2W        |
| 1 | 224 | 00 | 00 | Eastbound - Runner           |
| 1 | 228 | 00 | 00 | North - Hump - Lead          |
| 1 | 229 | 00 | 00 | South - Hump - Lead          |
| 1 | 230 | 00 | 00 | Hump - Lead                  |
| 1 | 603 | 00 | 00 | So. Rec. & Dept. Yd. Tk.#S-3 |
| 1 | 604 | 00 | 00 | So. Rec. & Dept. Yd. Tk.#S-4 |

# CHEEKTOWAGA NY (FRONTIER YARD)

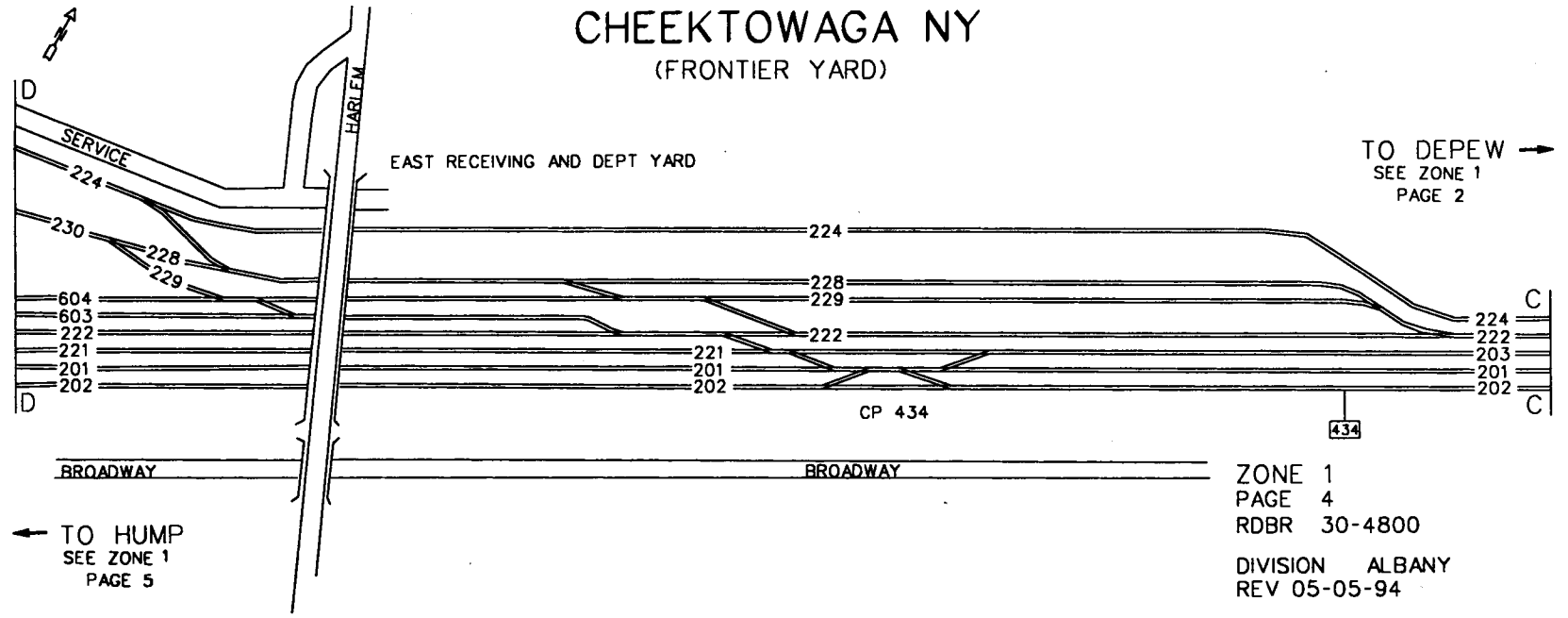

TO DEPEW →  
SEE ZONE 1  
PAGE 2

← TO HUMP  
SEE ZONE 1  
PAGE 5

ZONE 1  
PAGE 4  
RDBR 30-4800  
DIVISION ALBANY  
REV 05-05-94

- 1 001 00 00 Frontier - Yd. Class - Tk.#1
- 1 002 00 00 Frontier - Yd. Class - Tk.#2
- 1 003 00 00 Frontier - Yd. Class - Tk.#3
- 1 004 00 00 Frontier - Yd. Class - Tk.#4
- 1 005 00 00 Frontier - Yd. Class - Tk.#5
- 1 006 00 00 Frontier - Yd. Class - Tk.#6
- 1 007 00 00 Frontier - Yd. Class - Tk.#7
- 1 008 00 00 Frontier - Yd. Class - Tk.#8
- 1 009 00 00 Frontier - Yd. Class - Tk.#9
- 1 010 00 00 Frontier - Yd. Class - Tk.#10
- 1 011 00 00 Frontier - Yd. Class - Tk.#11
- 1 012 00 00 Frontier - Yd. Class - Tk.#12
- 1 013 00 00 Frontier - Yd. Class - Tk.#13
- 1 014 00 00 Frontier - Yd. Class - Tk.#14
- 1 015 00 00 Frontier - Yd. Class - Tk.#15
- 1 016 00 00 Frontier - Yd. Class - Tk.#16
- 1 017 00 00 Frontier - Yd. Class - Tk.#17
- 1 019 00 00 Frontier - Yd. Class - Tk.#19
- 1 020 00 00 Frontier - Yd. Class - Tk.#20
- 1 021 00 00 Frontier - Yd. Class - Tk.#21
- 1 022 00 00 Frontier - Yd. Class - Tk.#22
- 1 023 00 00 Frontier - Yd. Class - Tk.#23
- 1 024 00 00 Frontier - Yd. Class - Tk.#24
- 1 025 00 00 Frontier - Yd. Class - Tk.#25
- 1 026 00 00 Frontier - Yd. Class - Tk.#26
- 1 027 00 00 Frontier - Yd. Class - Tk.#27
- 1 028 00 00 Frontier - Yd. Class - Tk.#28
- 1 029 00 00 Frontier - Yd. Class - Tk.#29
- 1 030 00 00 Frontier - Yd. Class - Tk.#30
- 1 031 00 00 Frontier - Yd. Class - Tk.#31
- 1 032 00 00 Frontier - Yd. Class - Tk.#32
- 1 033 00 00 Frontier - Yd. Class - Tk.#33
- 1 034 00 00 Frontier - Yd. Class - Tk.#34
- 1 035 00 00 Frontier - Yd. Class - Tk.#35
- 1 036 00 00 Frontier - Yd. Class - Tk.#36
- 1 037 00 00 Frontier - Yd. Class - Tk.#37
- 1 038 00 00 Frontier - Yd. Class - Tk.#38
- 1 039 00 00 Frontier - Yd. Class - Tk.#39
- 1 040 00 00 Frontier - Yd. Class - Tk.#40
- 1 041 00 00 Frontier - Yd. Class - Tk.#41
- 1 042 00 00 Frontier - Yd. Class - Tk.#42
- 1 043 00 00 Frontier - Yd. Class - Tk.#43
- 1 044 00 00 Frontier - Yd. Class - Tk.#44
- 1 045 00 00 Frontier - Yd. Class - Tk.#45
- 1 046 00 00 Frontier - Yd. Class - Tk.#46

|   |     |    |    |                                       |
|---|-----|----|----|---------------------------------------|
| 1 | 266 | 00 | 00 | Tk.#6 - Lead                          |
| 1 | 267 | 00 | 00 | Tk.#7 - Lead                          |
| 1 | 270 | 00 | 00 | 6 Yard Lead                           |
| 1 | 271 | 00 | 00 | 5 Yard Lead                           |
| 1 | 272 | 00 | 00 | Yd. Lead                              |
| 1 | 273 | 00 | 00 | Tk.#3 - Yd. Lead                      |
| 1 | 274 | 00 | 00 | Tk.#4 - Yd. Lead                      |
| 1 | 290 | 00 | 00 | Sycamore St. Branch                   |
| 1 | 299 | 00 | 00 | South Hump By Pass                    |
| 1 | 401 | 00 | 00 | Group #1 Lead                         |
| 1 | 402 | 00 | 00 | Group #2 Lead                         |
| 1 | 403 | 00 | 00 | Group #3 Lead                         |
| 1 | 404 | 00 | 00 | Group #4 Lead                         |
| 1 | 405 | 00 | 00 | Group #5 Lead                         |
| 1 | 406 | 00 | 00 | Group #6 Lead                         |
| 1 | 407 | 00 | 00 | Group #7 Lead                         |
| 1 | 501 | 00 | 00 | Frontier - Yd. Car Shop - Tk.#1       |
| 1 | 502 | 00 | 00 | Frontier - Yd. Car Shop - Tk.#2       |
| 1 | 503 | 00 | 00 | Frontier - Yd. Car Shop - Tk.#3       |
| 1 | 504 | 00 | 00 | Frontier - Yd. Car Shop - Tk.#4       |
| 1 | 505 | 00 | 00 | Frontier - Yd. Car Shop - Tk.#5       |
| 1 | 540 | 00 | 00 | North - Cab. Tk.                      |
| 1 | 540 | 01 | 04 | Archer Daniels Midland (Lease 250 Ft) |
| 1 | 541 | 00 | 00 | South - Cab. Tk.                      |
| 1 | 543 | 00 | 00 | Snow Plow                             |
| 1 | 545 | 00 | 00 | Old - Steam Crane                     |
| 1 | 547 | 00 | 00 | Flexi Flo - South Tk.                 |
| 1 | 548 | 00 | 00 | Flexi Flo - South Steam Tk.           |
| 1 | 549 | 00 | 00 | Flexi Flo - Middle Tk.                |
| 1 | 550 | 00 | 00 | Flexi Flo - North Tk.                 |
| 1 | 557 | 00 | 00 | Store House                           |
| 1 | 559 | 00 | 00 | Frontier - Diesel Facility - No. Hse  |
| 1 | 560 | 00 | 00 | Frontier - Diesel Facility - So. Hse  |
| 1 | 561 | 00 | 00 | Frontier - Diesel Facility - Tk. #1   |
| 1 | 562 | 00 | 00 | Frontier - Diesel Facility - Tk. #2   |
| 1 | 563 | 00 | 00 | Frontier - Diesel Facility - Tk. #3   |
| 1 | 564 | 00 | 00 | Frontier - Diesel Facility - Tk. #4   |
| 1 | 565 | 00 | 00 | Frontier - Diesel Facility - Tk. #5   |
| 1 | 603 | 00 | 00 | So. Rec. & Dept. Yd. Tk.#S-3          |
| 1 | 604 | 00 | 00 | So. Rec. & Dept. Yd. Tk.#S-4          |
| 1 | 605 | 00 | 00 | So. Rec. & Dept. Yd. Tk.#S-5          |
| 1 | 606 | 00 | 00 | So. Rec. & Dept. Yd. Tk.#S-6          |
| 1 | 607 | 00 | 00 | So. Rec. & Dept. Yd. Tk.#S-7          |
| 1 | 608 | 00 | 00 | So. Rec. & Dept. Yd. Tk.#S-8          |
| 1 | 609 | 00 | 00 | So. Rec. & Dept. Yd. Tk.#S-9          |



1 047 00 00 Frontier - Yd. Class - Tk.#47  
1 048 00 00 Frontier - Yd. Class - Tk.#48  
1 049 00 00 Frontier - Yd. Class - Tk.#49  
1 050 00 00 Frontier - Yd. Class - Tk.#50  
1 051 00 00 Frontier - Yd. Class - Tk.#51  
1 052 00 00 Frontier - Yd. Class - Tk.#52  
1 053 00 00 Frontier - Yd. Class - Tk.#53  
1 054 00 00 Frontier - Yd. Class - Tk.#54  
1 055 00 00 Frontier - Yd. Class - Tk.#55  
1 056 00 00 Frontier - Yd. Class - Tk.#56  
1 057 00 00 Frontier - Yd. Class - Tk.#57  
1 058 00 00 Frontier - Yd. Class - Tk.#58  
1 059 00 00 Frontier - Yd. Class - Tk.#59  
1 060 00 00 Frontier - Yd. Class - Tk.#60  
1 061 00 00 Frontier - Yd. Class - Tk.#61  
1 062 00 00 Frontier - Yd. Class - Tk.#62  
1 063 00 00 Frontier - Yd. Class - Tk.#63  
1 201 00 00 Chicago - Line - Tk.#1  
1 202 00 00 Chicago - Line - Tk.#2  
1 218 00 00 Frontier - Yd. Tk.#18 (Scale)  
1 221 00 00 Running - Tk.South-1W  
1 222 00 00 Running - Tk.South-2W  
1 223 00 00 Runner  
1 224 00 00 Eastbound - Runner  
1 225 00 00 North - Runner  
1 226 00 00 Eastward - Bypass  
1 227 00 00 North - Eng. House Wye Tk.  
1 230 00 00 Hump - Lead  
1 231 00 00 North - Feeder  
1 232 00 00 South - Feeder  
1 233 00 00 Erie Straight  
1 234 00 00 Escape - Tk.  
1 236 00 00 South - Eng. House Wye Tk.  
1 239 00 00 Buffalo - Ind. Park - Lead  
1 241 00 00 Erie - Straight Tk.#(3-W5)  
1 247 00 00 Lead  
1 248 00 00 Tk.#19 - Lead  
1 251 00 00 Tk.#1 - Loop  
1 252 00 00 Tk.#2 - Loop  
1 253 00 00 Tk.#3 - Loop  
1 254 00 00 Diesel - Spur  
1 255 00 00 Loop - Lead  
1 263 00 00 Pullman - Lead  
1 264 00 00 Tk.#4 - Lead  
1 265 00 00 Tk.#5 - Lead

ZONE 1 Rev 12/20/96

PAGE 5 (continued)

|   |     |    |    |                               |
|---|-----|----|----|-------------------------------|
| 1 | 610 | 00 | 00 | So. Rec. & Dept. Yd. Tk.#S-10 |
| 1 | 618 | 00 | 00 | Tk.#18 - Spur                 |
| 1 | 621 | 00 | 00 | No. Rec. & Dept. Yd. Tk.#N-1  |
| 1 | 622 | 00 | 00 | No. Rec. & Dept. Yd. Tk.#N-2  |
| 1 | 623 | 00 | 00 | No. Rec. & Dept. Yd. Tk.#N-3  |
| 1 | 624 | 00 | 00 | No. Rec. & Dept. Yd. Tk.#N-4  |
| 1 | 625 | 00 | 00 | No. Rec. & Dept. Yd. Tk.#N-5  |
| 1 | 626 | 00 | 00 | No. Rec. & Dept. Yd. Tk.#N-6  |
| 1 | 628 | 00 | 00 | No. Rec. & Dept. Yd. Tk.#N-8  |
| 1 | 753 | 01 | 04 | Vacant                        |
| 1 | 757 | 99 | 99 | Vacant                        |
| 1 | 759 | 99 | 99 | Vacant                        |
| 1 | 760 | 99 | 99 | Vacant                        |
| 1 | 764 | 99 | 99 | USPCI                         |



ZONE 1

Rev 2/7/97

PAGE 6

1 233 00 00 Erie Straight  
1 630 00 00 Walden Ave. Yd. Tk.#30  
1 630 99 99 Midwest Steel Alloy  
1 631 00 00 Walden Ave. Yd. Tk.#31  
1 633 00 00 Walden Ave. Yd. Tk.#5  
1 634 00 00 Walden Ave. Yd. Tk.#6

# CHEEKTOWAGA NY



← TO FRONTIER YARD  
SEE ZONE 1  
PAGE 5

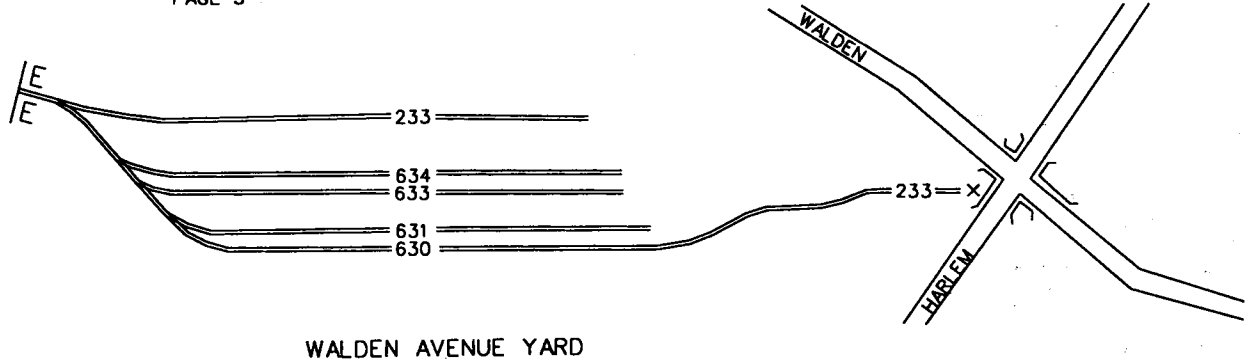

ZONE 1  
PAGE 6  
RDBR 30-4833  
DIVISION ALBANY  
REV 04-04-94

**ZONE 1**

**Rev 12/20/96**

**PAGE 7**

- 1 256 00 00 Former - (Erie Running Tk.)
- 1 257 00 00 Walden - Runaround
- 1 270 00 00 6 Yard Lead
- 1 271 00 00 5 Yard Lead
- 1 275 00 00 Belt Line Branch Tk#2
- 1 276 00 00 Belt Line Branch Tk#1
- 1 290 00 00 Sycamore Yard Lead
- 1 291 00 00 Belt Line - Branch - Tk.#1
- 1 292 00 00 Belt Line - Branch - Tk.#2

# BUFFALO NY

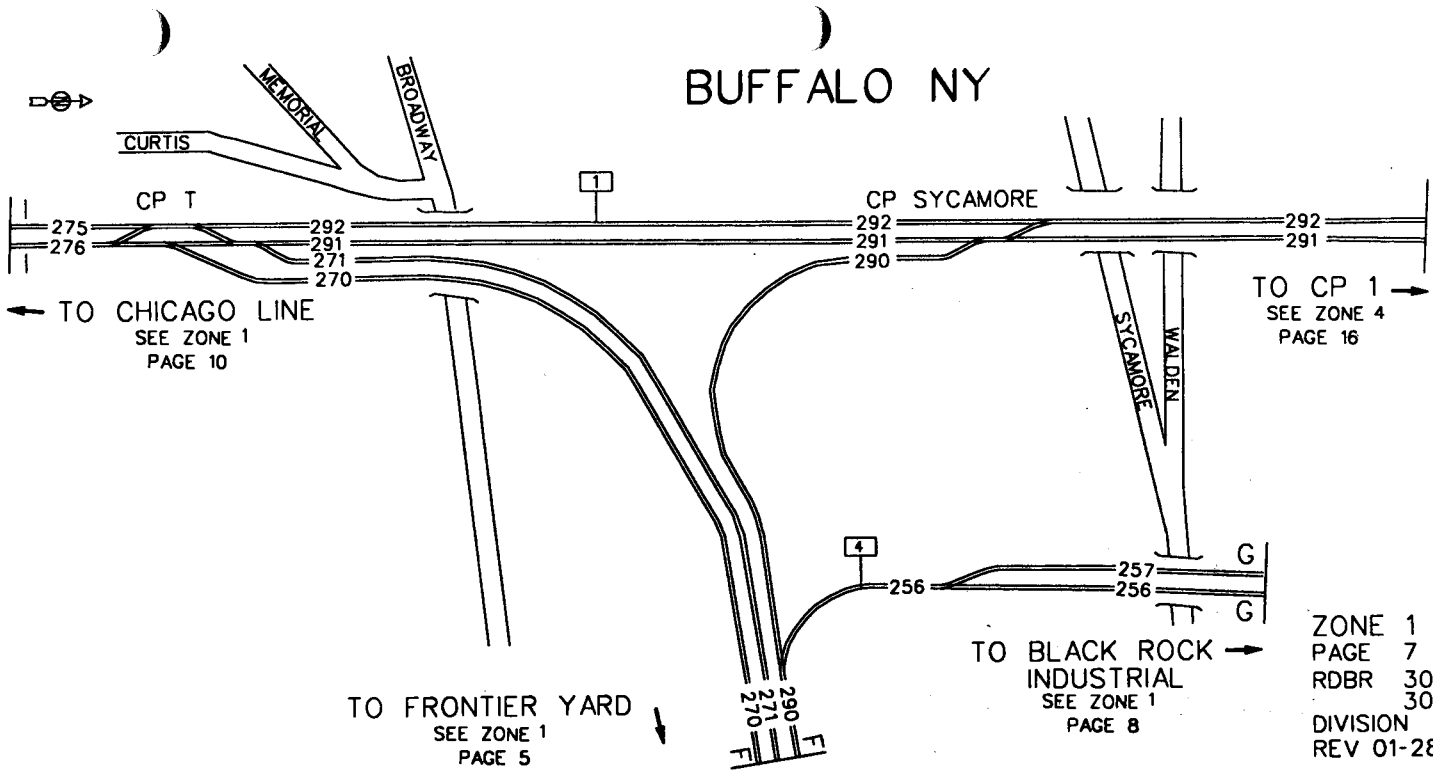

← TO CHICAGO LINE  
SEE ZONE 1  
PAGE 10

TO CP 1 →  
SEE ZONE 4  
PAGE 16

TO FRONTIER YARD  
SEE ZONE 1  
PAGE 5

TO BLACK ROCK INDUSTRIAL →  
SEE ZONE 1  
PAGE 8

ZONE 1  
PAGE 7  
RDBR 30-4842 30-4835  
30-6466  
DIVISION ALBANY  
REV 01-28-97

ZONE 1

Rev 12/9/96

PAGE 8

|   |     |    |    |                              |
|---|-----|----|----|------------------------------|
| 1 | 256 | 00 | 00 | Former - (Erie Running Tk.)  |
| 1 | 257 | 00 | 00 | Walden - Runaround           |
| 1 | 258 | 00 | 00 | Erie Industrial TK WestBound |
| 1 | 269 | 00 | 00 | Industrial Siding            |
| 1 | 638 | 00 | 00 | Water - Tk.                  |
| 1 | 641 | 00 | 00 | Cemetary - Tk.#1             |
| 1 | 642 | 00 | 00 | Cemetary - Tk.#2             |
| 1 | 773 | 01 | 04 | Bison Laboratories           |
| 1 | 780 | 99 | 99 | American Axle MFG #6         |
| 1 | 781 | 99 | 99 | American Axle MFG #5         |
| 1 | 782 | 99 | 99 | American Axle MFG #4         |
| 1 | 783 | 99 | 99 | American Axle MFG #3         |
| 1 | 784 | 99 | 99 | American Axle MFG #2         |
| 1 | 785 | 99 | 99 | American Axle MFG #1         |



# BUFFALO NY

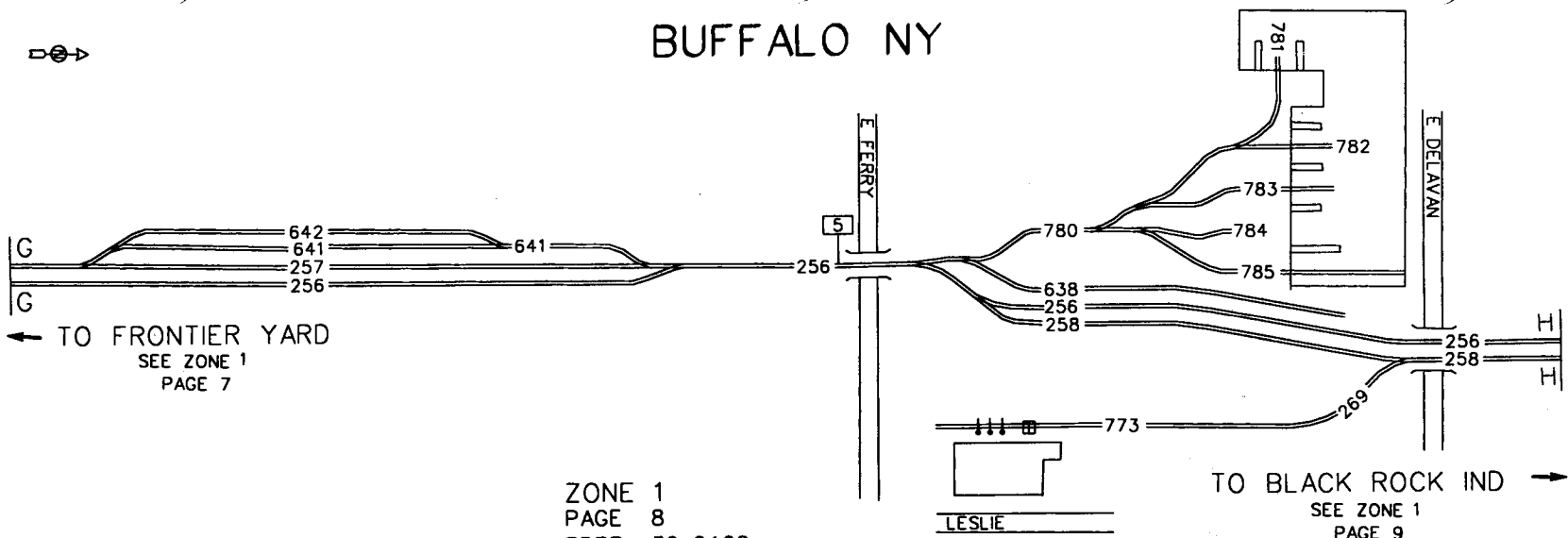

ZONE 1  
PAGE 8  
RDBR 30-6462  
30-6466  
DIVISION ALBANY  
REV 04-04-94

TO BLACK ROCK IND →  
SEE ZONE 1  
PAGE 9

ZONE 1

Rev 12/9/96

PAGE 9

|   |     |    |    |                              |
|---|-----|----|----|------------------------------|
| 1 | 256 | 00 | 00 | Former - (Erie Running Tk.)  |
| 1 | 258 | 00 | 00 | Erie Industrial Tk WestBound |
| 1 | 262 | 00 | 00 | Runaround                    |
| 1 | 791 | 99 | 99 | Vacant                       |
| 1 | 792 | 99 | 99 | North Shore Recycling        |
| 1 | 793 | 01 | 01 | Vacant                       |
| 1 | 794 | 99 | 99 | Vacant                       |

# BUFFALO NY

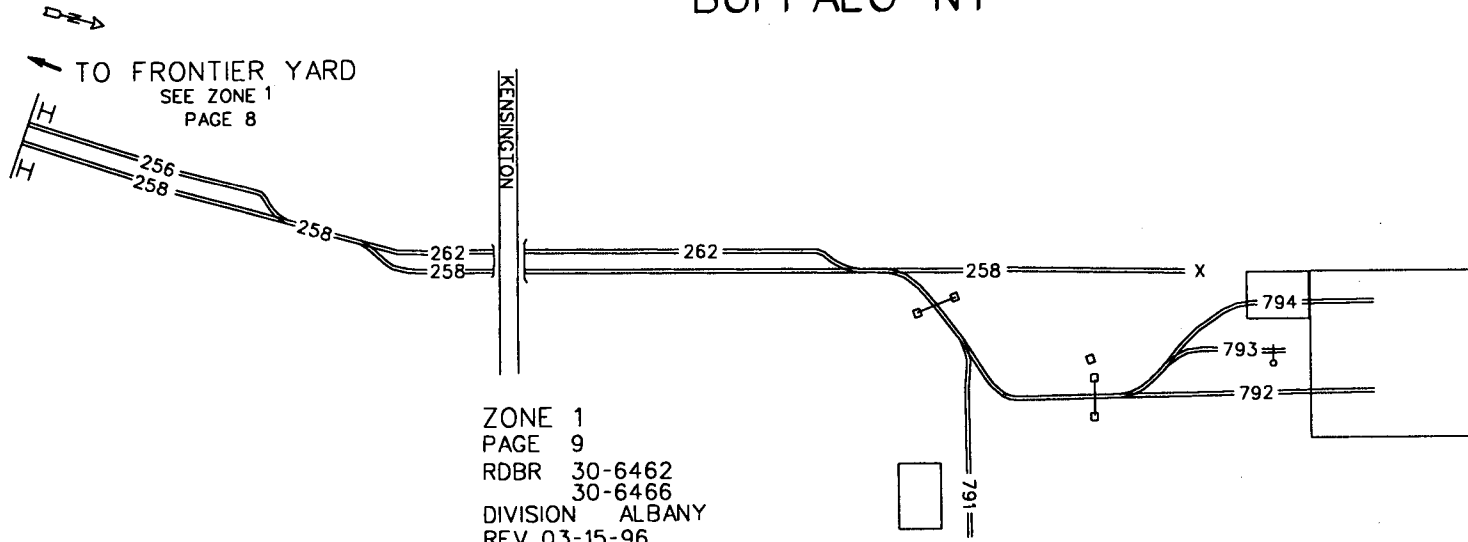

ZONE 1  
PAGE 9  
RDBR 30-6462  
30-6466  
DIVISION ALBANY  
REV 03-15-96

ZONE 1

Rev 12/9/96

PAGE 10

|   |     |    |    |                         |
|---|-----|----|----|-------------------------|
| 1 | 201 | 00 | 00 | Chicago - Line - Tk.#1  |
| 1 | 202 | 00 | 00 | Chicago - Line - Tk.#2  |
| 1 | 211 | 00 | 00 | Niagara - Branch        |
| 1 | 255 | 00 | 00 | Loop - Lead             |
| 1 | 273 | 00 | 00 | Tk.#3 - Yd. Lead        |
| 1 | 274 | 00 | 00 | Tk.#4 - Yd. Lead        |
| 1 | 275 | 00 | 00 | Belt Line Branch Tk#2   |
| 1 | 276 | 00 | 00 | Belt Line Branch Tk#1   |
| 1 | 278 | 00 | 00 | Lovejoy - Industrial Tk |
| 1 | 284 | 00 | 00 | Stock - Yd. Lead        |

# BUFFALO NY



← TO EXCHANGE ST  
SEE ZONE 2  
PAGE 6

ZONE 1  
PAGE 10  
RDBR 30-4800 30-4842 30-6421  
30-4843 30-6467  
DIVISION ALBANY  
REV 01-28-97

TO CP T  
SEE ZONE 1  
PAGE 7

TO FRONTIER YARD →  
SEE ZONE 1  
PAGE 5

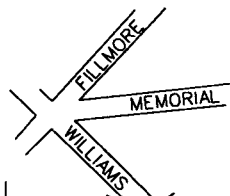

CP 437

437

436

211

211

201

202

274

275

276

275

276

255

255

274

273

201

202

J

J

BAILEY

TO OLD FW  
SEE ZONE 2  
PAGE 6

TO STOCK YARD  
SEE ZONE 1  
PAGE 11

TO IQ  
SEE ZONE 1  
PAGE 11

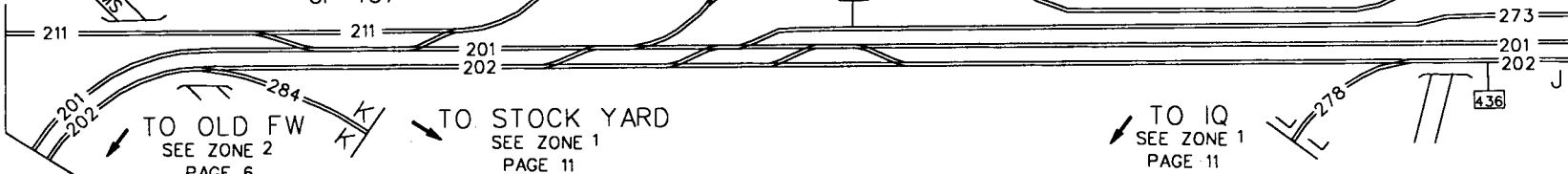

|   |     |    |    |                                     |
|---|-----|----|----|-------------------------------------|
| 1 | 278 | 00 | 00 | Lovejoy - Industrial Tk             |
| 1 | 279 | 00 | 00 | Industry - Tk.                      |
| 1 | 280 | 00 | 00 | Car Shop - Lead                     |
| 1 | 281 | 00 | 00 | Van - Lead                          |
| 1 | 282 | 00 | 00 | Post Office - Lead                  |
| 1 | 283 | 00 | 00 | Water Rack                          |
| 1 | 284 | 00 | 00 | Stock - Yd. Lead                    |
| 1 | 285 | 00 | 00 | Stock - Yd. Lead                    |
| 1 | 287 | 00 | 00 | Federal Baking Lead                 |
| 1 | 551 | 00 | 00 | TVT - Tk.#1                         |
| 1 | 551 | 97 | 97 | Universal Forests Products          |
| 1 | 552 | 00 | 00 | TVT - Tk.#2                         |
| 1 | 553 | 00 | 00 | West Ramp                           |
| 1 | 556 | 00 | 00 | East - Ramp                         |
| 1 | 570 | 00 | 00 | President's Track                   |
| 1 | 645 | 00 | 00 | Stock - Yd. Tk.#5                   |
| 1 | 645 | 01 | 03 | Chemical Waste Mngmt (Lease 200 Ft) |
| 1 | 645 | 97 | 97 | Clean Harbors Environment           |
| 1 | 646 | 00 | 00 | Stock - Yd. Tk.#6                   |
| 1 | 647 | 00 | 00 | Stock - Yd. Tk.#7                   |
| 1 | 649 | 00 | 00 | Stock - Yd. Tk.#9                   |
| 1 | 649 | 01 | 30 | NGL Supply                          |
| 1 | 650 | 00 | 00 | Stock - Yd. Tk.#10                  |
| 1 | 651 | 00 | 00 | Stock - Yd. Tk.#11                  |
| 1 | 652 | 00 | 00 | Stock - Yd. Tk.#12                  |
| 1 | 656 | 00 | 00 | Camp Car Track                      |
| 1 | 803 | 99 | 99 | Deltacraft Paper Co                 |
| 1 | 805 | 99 | 99 | Gohr Distributors                   |
| 1 | 809 | 01 | 01 | Federal Baking Supply               |
| 1 | 809 | 02 | 04 | Eber Bros.                          |
| 1 | 811 | 99 | 99 | Vacant - (Former Hog Tk.)           |

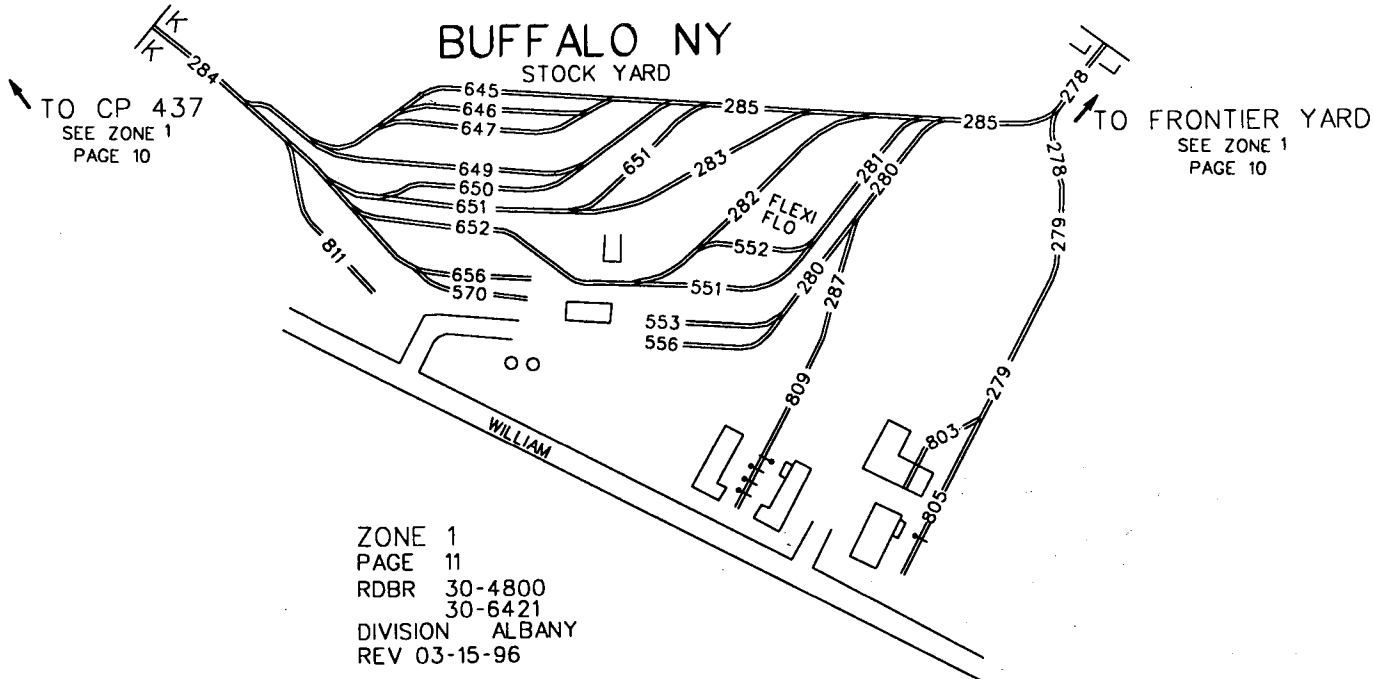

TO CP 437  
SEE ZONE 1  
PAGE 10

TO FRONTIER YARD  
SEE ZONE 1  
PAGE 10

# BUFFALO NY

STOCK YARD

ZONE 1  
PAGE 11  
RDBR 30-4800  
30-6421  
DIVISION ALBANY  
REV 03-15-96

ZONE 1

Rev 12/9/96

PAGE 12

|   |     |    |    |                                   |
|---|-----|----|----|-----------------------------------|
| 1 | 211 | 00 | 00 | Southern - Tier - Line            |
| 1 | 237 | 00 | 00 | Howard St. Running - Tk.          |
| 1 | 242 | 00 | 00 | NFFT Market - Lead                |
| 1 | 244 | 00 | 00 | Bison - Running - Tk.             |
| 1 | 246 | 00 | 00 | North Yd. Lead                    |
| 1 | 661 | 00 | 00 | (D&H) - I/C - Tk.#1 - No. Yd. Tk. |
| 1 | 663 | 00 | 00 | (D&H) - I/C - Tk.#3 - No. Yd. Tk. |
| 1 | 665 | 00 | 00 | (D&H) - I/C - Tk.#5 - No. Yd. Tk. |
| 1 | 666 | 00 | 00 | (D&H) - I/C - Tk.#6 - No. Yd. Tk. |
| 1 | 667 | 00 | 00 | (D&H) - I/C - Tk.#7 - No. Yd. Tk. |
| 1 | 668 | 00 | 00 | (N&S) - Connection. Tk.           |
| 1 | 765 | 99 | 99 | R&R Salvage                       |
| 1 | 767 | 99 | 99 | Trippi Foods                      |



# BUFFALO NY

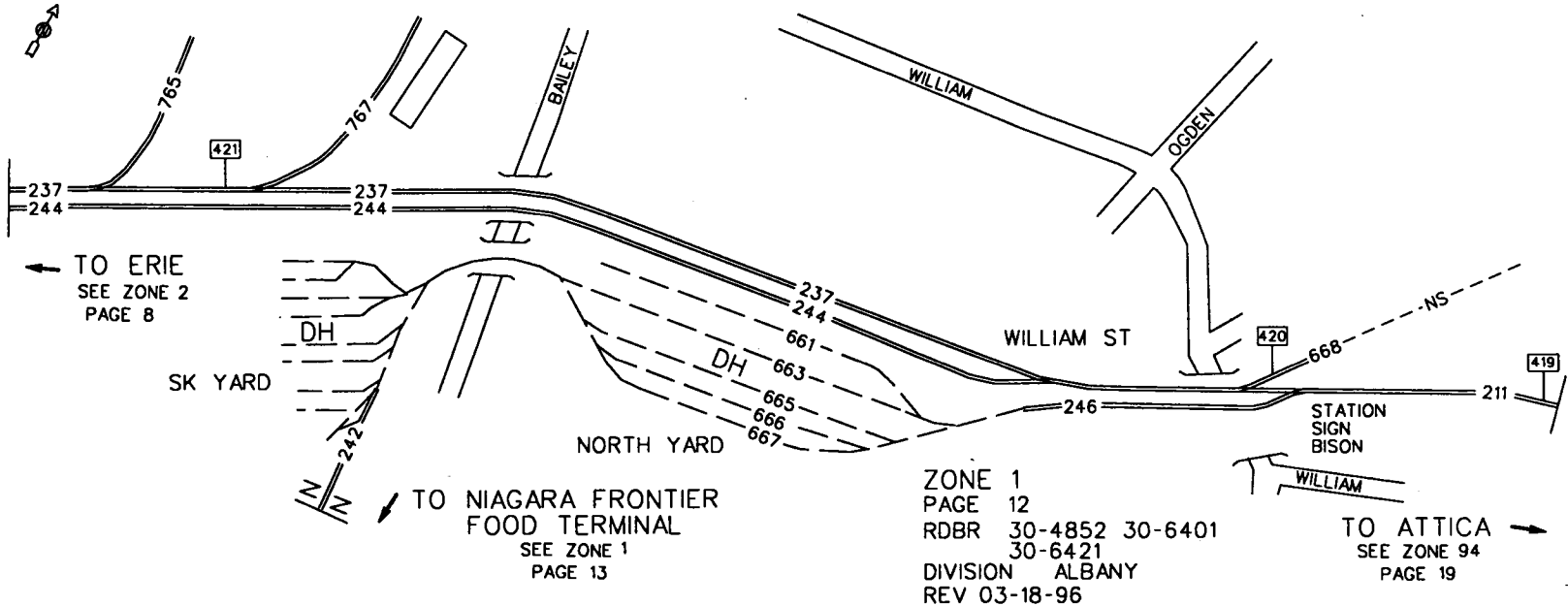

TO ERIE  
SEE ZONE 2  
PAGE 8

SK YARD

DH

N

N

TO NIAGARA FRONTIER  
FOOD TERMINAL  
SEE ZONE 1  
PAGE 13

NORTH YARD

DH

ZONE 1  
PAGE 12  
RDBR 30-4852 30-6401  
30-6421  
DIVISION ALBANY  
REV 03-18-96

STATION  
SIGN  
BISON

TO ATTICA  
SEE ZONE 94  
PAGE 19

1 242 00 00 NFFT Market - Lead  
1 243 00 00 Ind. Lead - Tk.  
1 245 00 00 Pohlman Lead  
1 250 00 00 Ind. Lead - Tk.  
1 287 00 00 Stub  
1 685 00 00 Runaround  
1 686 00 00 Market - Rec. Yd. Tk.#6  
1 815 01 05 U. S. Sugar  
1 817 01 05 Canadian American Packaging  
1 819 01 05 Chudy Paper  
1 822 97 97 Scoular  
1 822 97 97 NFFT - (Team Tk.#3)  
1 822 97 97 Tarantino Foods Inc  
1 822 97 97 Sunshine Feed Grain  
1 822 97 97 Metro Plastics  
1 822 97 97 R D Scheible Son  
1 822 97 97 Mt Chirico  
1 822 97 97 Triple G Farms Inc  
1 822 97 97 David C Haas  
1 822 97 97 James Desiderio Inc  
1 822 97 97 Johnson Steel  
1 822 97 97 L Altman  
1 822 97 97 Louis J De Carlo and Sons Inc  
1 822 97 97 Matlack  
1 824 97 97 NFFT - (Team Tk.#6)  
1 825 97 97 Air Liquide America Corp  
1 825 97 97 Johnson International  
1 825 97 97 NFFT - (Team Tk.#5)  
1 827 97 97 NFFT - (Team Tk.#7)  
1 828 01 06 Bishop Potato - Tk.  
1 830 01 02 Irish Carbonic #5  
1 830 97 97 NFFT - Tk.#10  
1 830 97 97 McLean Thomas  
1 843 01 03 Pohlman Foundry

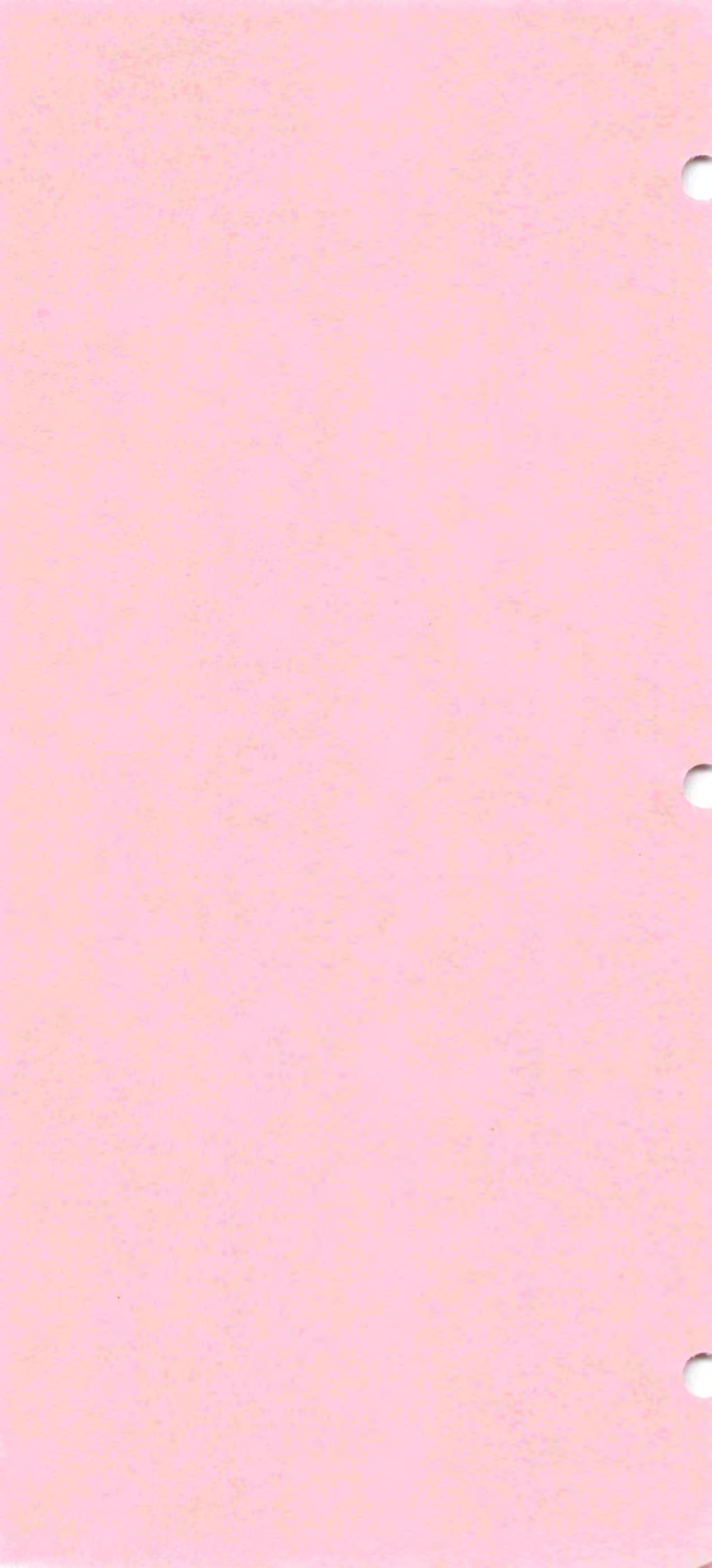

ZONE 1

Rev 12/9/96

PAGE 14

|   |     |    |    |                             |
|---|-----|----|----|-----------------------------|
| 1 | 217 | 00 | 00 | Connection DLWR             |
| 1 | 260 | 00 | 00 | Ind. Lead - Tk.             |
| 1 | 288 | 00 | 00 | Connection DLWR             |
| 1 | 296 | 00 | 00 | Runaround                   |
| 1 | 676 | 00 | 00 | Former - (Bison Yd. Tk.#76) |
| 1 | 695 | 00 | 00 | Interchange DLWR            |
| 1 | 849 | 01 | 09 | Benlin Whse.                |
| 1 | 850 | 99 | 99 | Benlin Whse.                |
| 1 | 851 | 99 | 99 | Benlin Warehouse            |
| 1 | 852 | 99 | 99 | Keystone Whse. (Pillsbury)  |
| 1 | 854 | 99 | 99 | Benlin Warehouse            |
| 1 | 855 | 01 | 03 | Benlin Warehouse            |
| 1 | 857 | 01 | 12 | Vacant                      |

CHEEKTOWAGA NY

SLOAN NY

BROADWAY

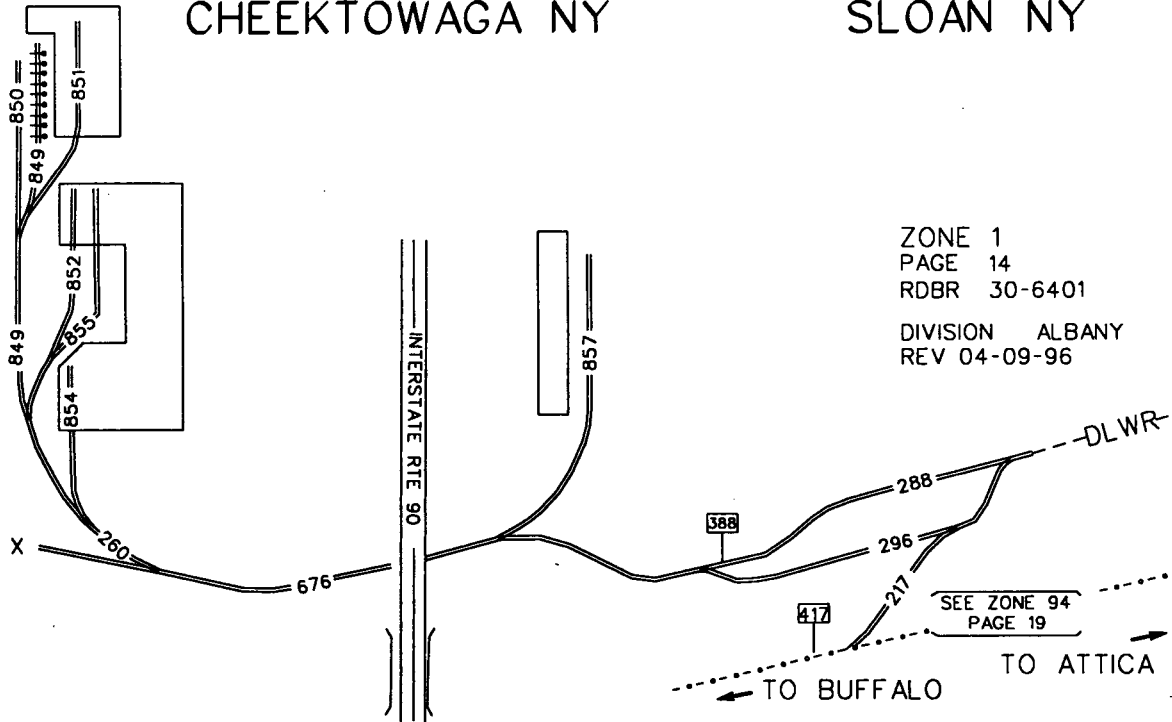

ZONE 1  
PAGE 14  
RDBR 30-6401

DIVISION ALBANY  
REV 04-09-96

SEE ZONE 94  
PAGE 19

TO BUFFALO

TO ATTICA

# OHIO ST-ZONE 2

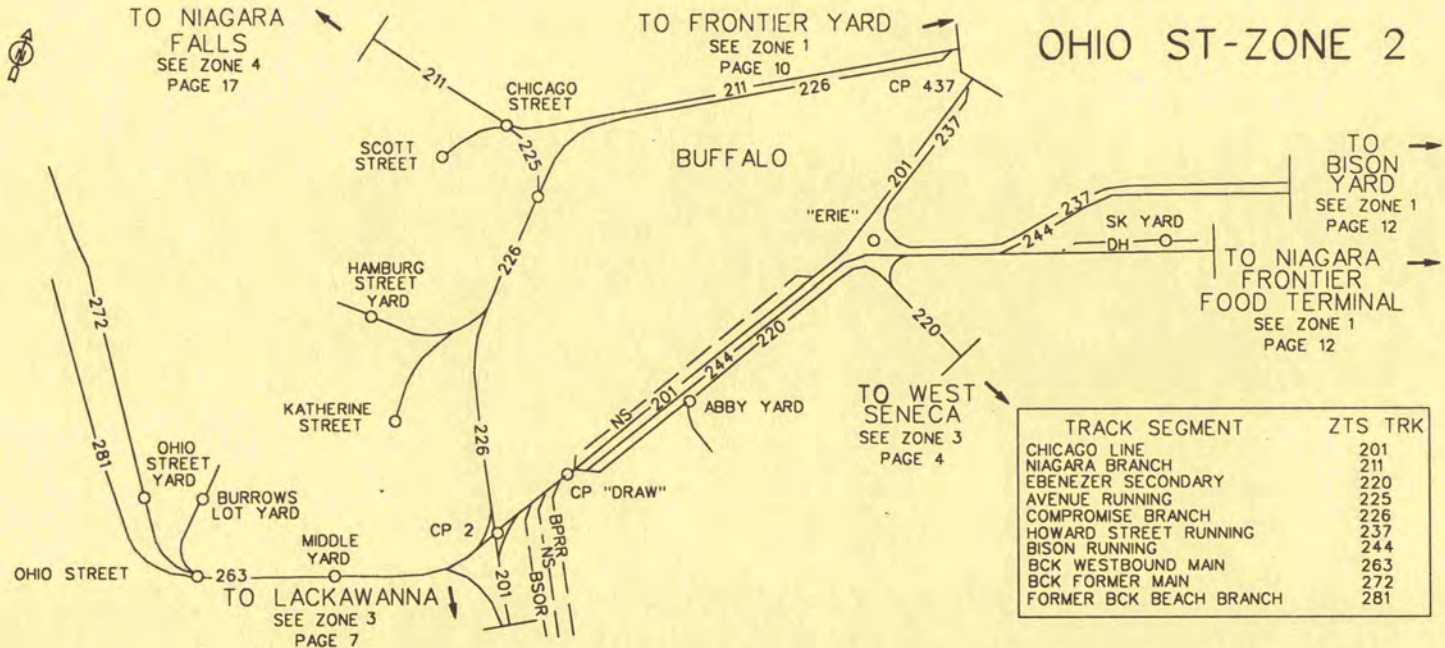

| TRACK SEGMENT           | ZTS TRK |
|-------------------------|---------|
| CHICAGO LINE            | 201     |
| NIAGARA BRANCH          | 211     |
| EBENEZER SECONDARY      | 220     |
| AVENUE RUNNING          | 225     |
| COMPROMISE BRANCH       | 226     |
| HOWARD STREET RUNNING   | 237     |
| BISON RUNNING           | 244     |
| BCK WESTBOUND MAIN      | 263     |
| BCK FORMER MAIN         | 272     |
| FORMER BCK BEACH BRANCH | 281     |

ZONE 2

Rev 12/10/96

PAGE 1

|   |     |    |    |                      |
|---|-----|----|----|----------------------|
| 2 | 211 | 00 | 00 | Niagara - Branch     |
| 2 | 212 | 00 | 00 | Industrial Lead      |
| 2 | 215 | 00 | 00 | News Runaround       |
| 2 | 704 | 99 | 99 | Buffalo Evening News |

# BUFFALO NY

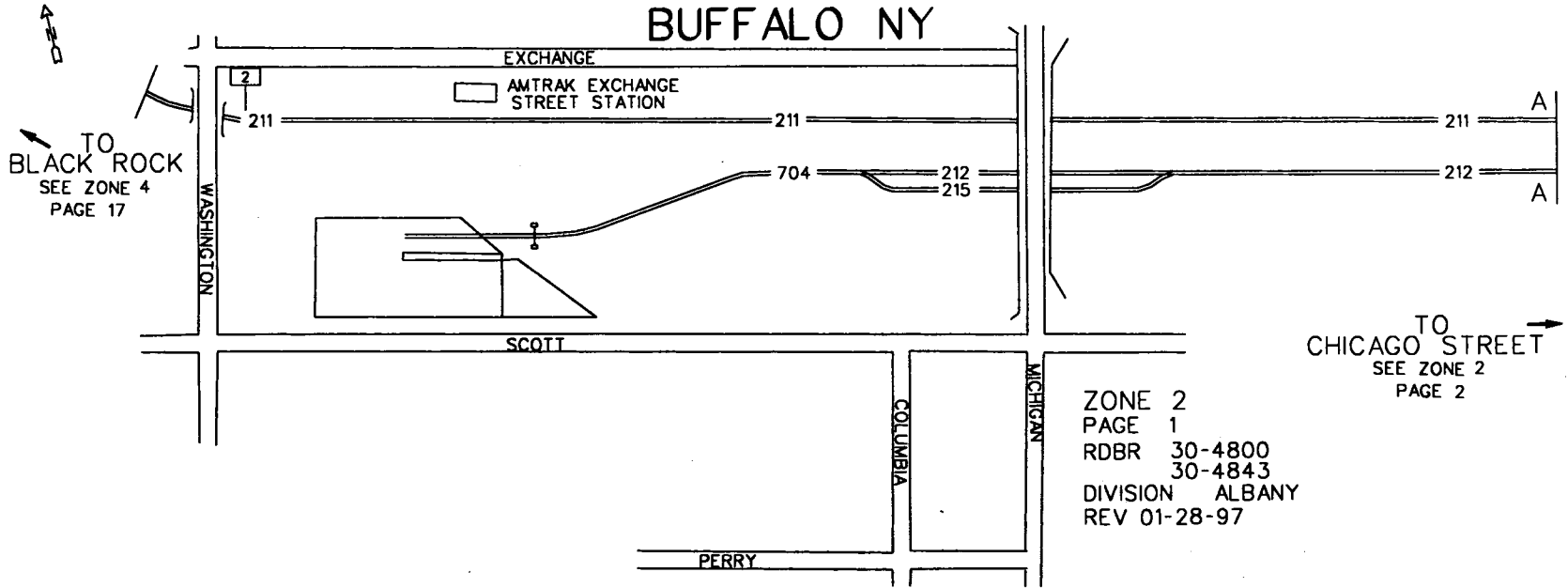

TO  
BLACK ROCK  
SEE ZONE 4  
PAGE 17

TO  
CHICAGO STREET  
SEE ZONE 2  
PAGE 2

ZONE 2  
PAGE 1  
RDBR 30-4800  
30-4843  
DIVISION ALBANY  
REV 01-28-97



ZONE 2

Rev 12/10/96

PAGE 2

|   |     |    |    |                          |
|---|-----|----|----|--------------------------|
| 2 | 211 | 00 | 00 | Niagara - Branch         |
| 2 | 212 | 00 | 00 | Industrial Lead          |
| 2 | 219 | 00 | 00 | Ind. Lead - Tk.          |
| 2 | 225 | 00 | 00 | Ave. Running - Tk.       |
| 2 | 226 | 00 | 00 | Compromise - Branch      |
| 2 | 701 | 01 | 04 | Stetson Chemical - Tk.#1 |
| 2 | 702 | 99 | 99 | Stetson Chemical - Tk.#2 |
| 2 | 726 | 99 | 99 | Gilbrator Steel Whse.    |
| 2 | 726 | 99 | 99 | Beals McCarthy           |

# BUFFALO NY

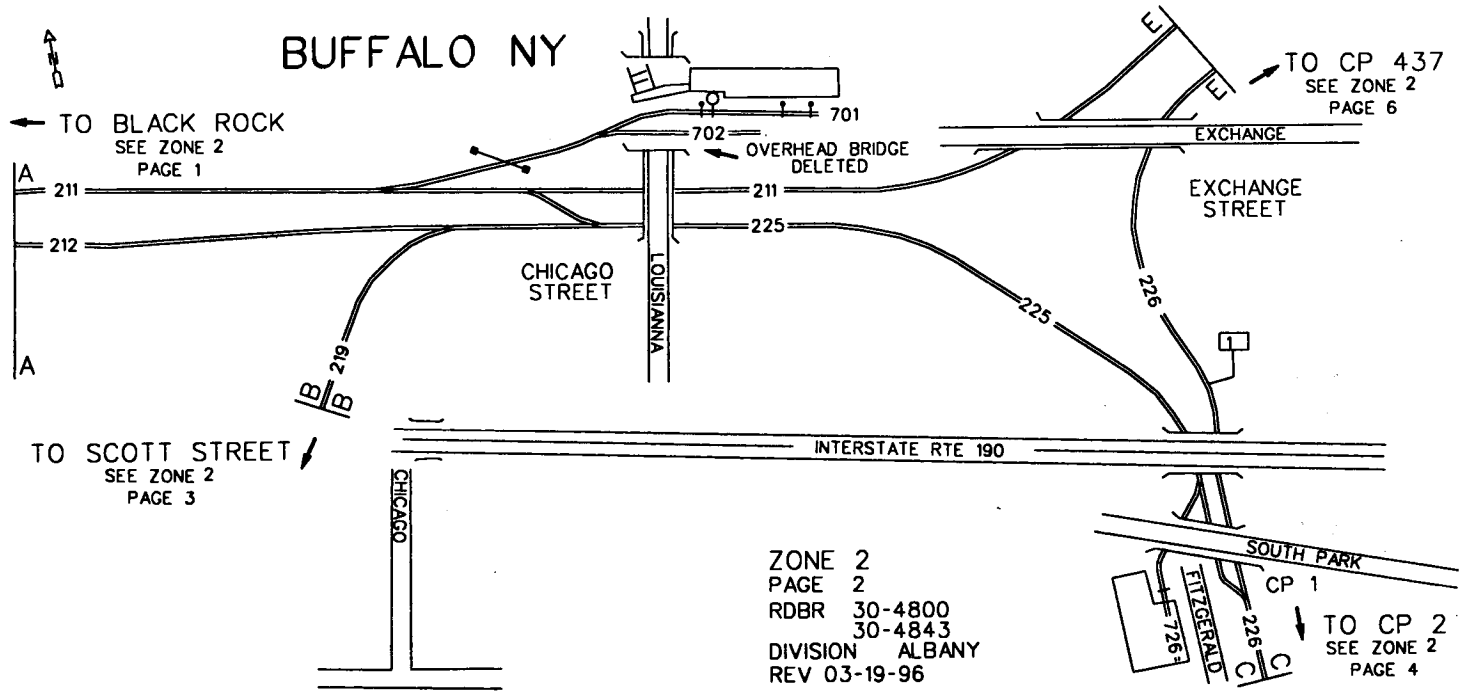

← TO BLACK ROCK  
SEE ZONE 2  
PAGE 1

TO CP 437  
SEE ZONE 2  
PAGE 6

TO SCOTT STREET  
SEE ZONE 2  
PAGE 3

TO CP 2  
SEE ZONE 2  
PAGE 4

ZONE 2  
PAGE 2  
RDBR 30-4800  
30-4843  
DIVISION ALBANY  
REV 03-19-96

ZONE 2

Rev 12/10/96

PAGE 3

|   |     |    |    |                 |
|---|-----|----|----|-----------------|
| 2 | 219 | 00 | 00 | Ind. Lead - Tk. |
| 2 | 222 | 00 | 00 | Ind. Lead - Tk. |
| 2 | 223 | 00 | 00 | Ind. Lead - Tk. |
| 2 | 720 | 01 | 01 | Vacant          |

←Z→

# BUFFALO NY

(SCOTT STREET)

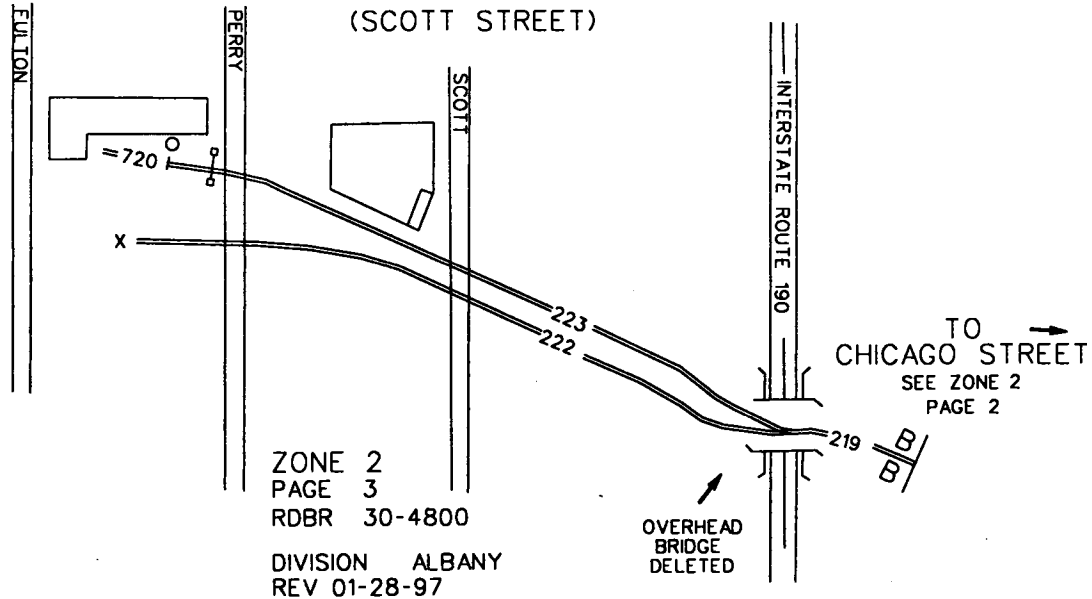

ZONE 2  
PAGE 3  
RDBR 30-4800

DIVISION ALBANY  
REV 01-28-97

ZONE 2

Rev 2/7/97

PAGE 4

|   |     |    |    |                          |
|---|-----|----|----|--------------------------|
| 2 | 226 | 00 | 00 | Compromise - Branch      |
| 2 | 227 | 00 | 00 | Hamburg St. Lead         |
| 2 | 228 | 00 | 00 | Runaround                |
| 2 | 229 | 00 | 00 | Standard - Lead          |
| 2 | 230 | 00 | 00 | Katherine St. Lead       |
| 2 | 261 | 00 | 00 | River - Tk.              |
| 2 | 617 | 00 | 00 | Hamburg St. Yd. Tk.#1    |
| 2 | 618 | 00 | 00 | Hamburg St. Yd. Tk.#2    |
| 2 | 619 | 00 | 00 | Hamburg St. Yd. Tk.#3    |
| 2 | 620 | 00 | 00 | Hamburg St. Yd. Tk.#4    |
| 2 | 729 | 01 | 01 | Manitoba                 |
| 2 | 730 | 01 | 03 | Great Lakes Paper Fibres |
| 2 | 731 | 01 | 01 | ADM Milling - Tk.#1      |
| 2 | 732 | 01 | 01 | ADM Milling - Tk.#2      |
| 2 | 733 | 01 | 01 | ADM Milling - Tk.#3      |
| 2 | 734 | 01 | 04 | Vacant                   |
| 2 | 736 | 01 | 03 | BOC Gases                |
| 2 | 845 | 00 | 00 | Diederich Warehouse      |

# BUFFALO NY

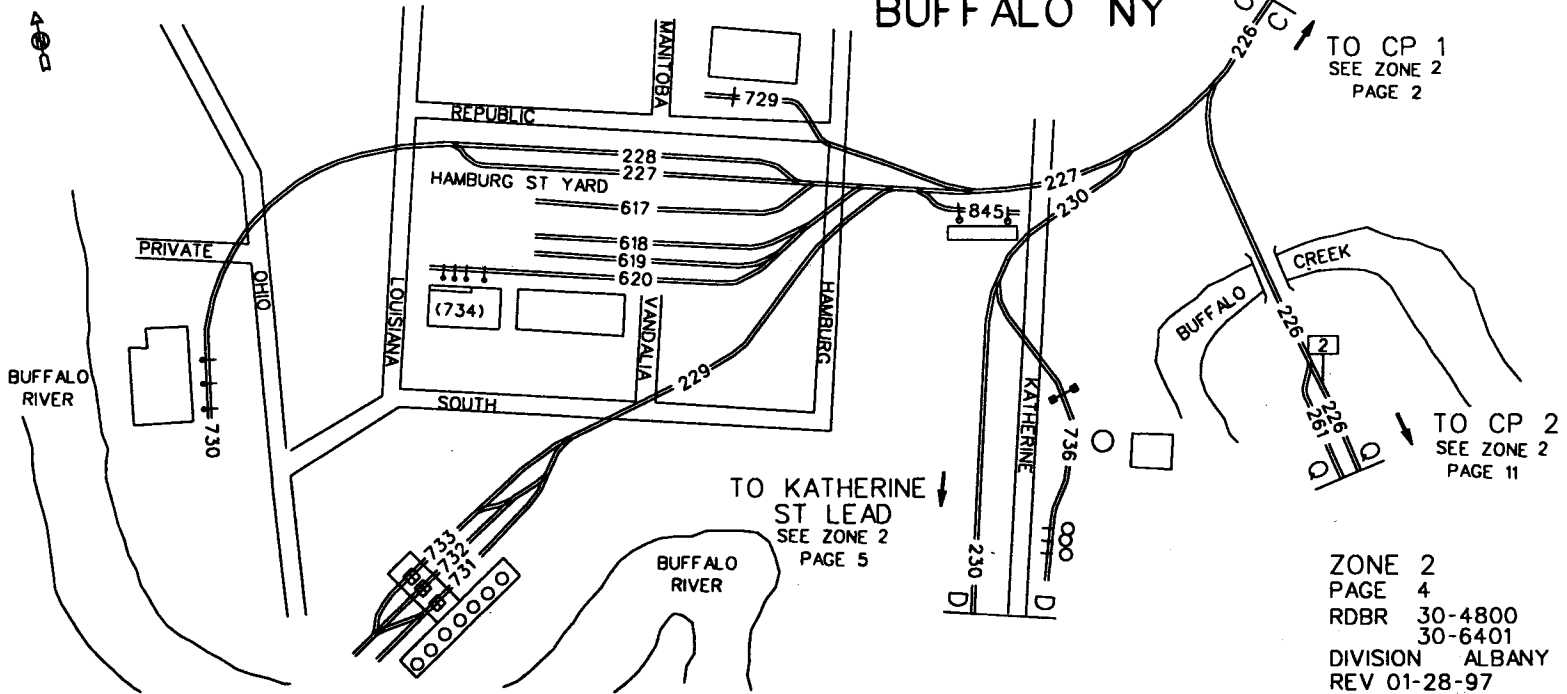

TO CP 1  
SEE ZONE 2  
PAGE 2

TO CP 2  
SEE ZONE 2  
PAGE 11

TO KATHERINE  
ST LEAD  
SEE ZONE 2  
PAGE 5

ZONE 2  
PAGE 4  
RDBR 30-4800  
30-6401  
DIVISION ALBANY  
REV 01-28-97

**ZONE 2**

**Rev 12/10/96**

**PAGE 5**

|   |     |    |    |                         |
|---|-----|----|----|-------------------------|
| 2 | 230 | 00 | 00 | Katherine St. Lead      |
| 2 | 738 | 01 | 04 | Vacant                  |
| 2 | 739 | 01 | 04 | Irish Carbonic          |
| 2 | 740 | 01 | 02 | Booth Oil(Safety Kleen) |
| 2 | 741 | 01 | 03 | Vacant                  |
| 2 | 742 | 01 | 02 | Vacant                  |

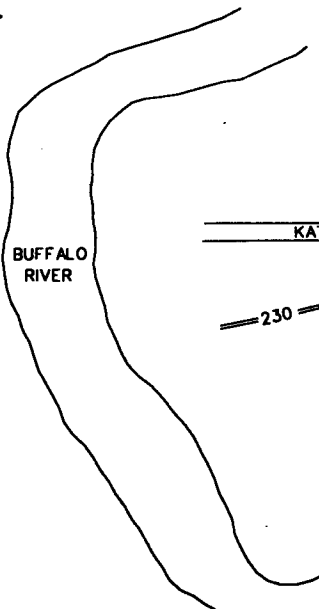

# BUFFALO NY

(KATHERINE ST LEAD)

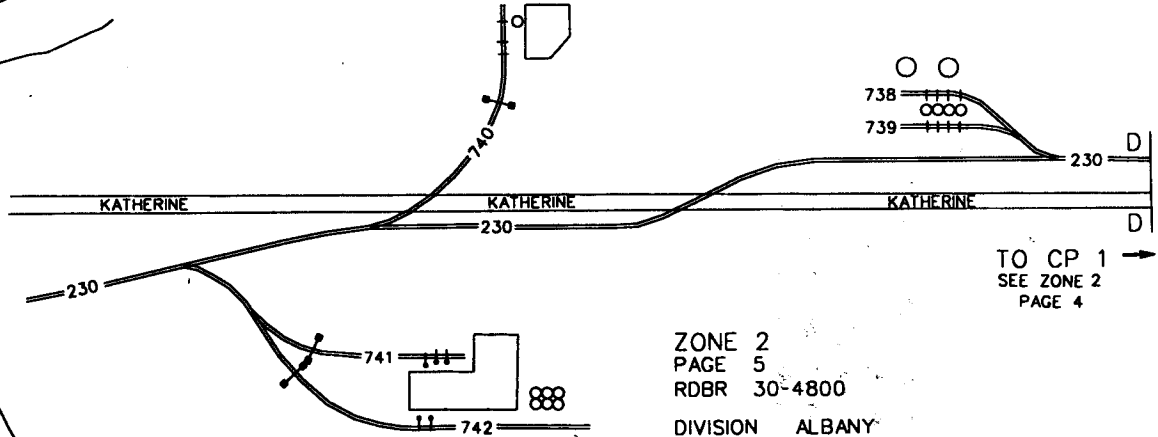

TO CP 1 →  
SEE ZONE 2  
PAGE 4

ZONE 2  
PAGE 5  
RDBR 30-4800  
DIVISION ALBANY  
REV 04-04-94



ZONE 2

Rev 12/10/96

PAGE 6

|   |     |    |    |                        |
|---|-----|----|----|------------------------|
| 2 | 201 | 00 | 00 | Chicago - Line - Tk.#1 |
| 2 | 202 | 00 | 00 | Chicago - Line - Tk.#2 |
| 2 | 211 | 00 | 00 | Niagara - Branch       |
| 2 | 226 | 00 | 00 | Compromise - Branch    |
| 2 | 237 | 00 | 00 | Howard St. Running     |

# BUFFALO NY

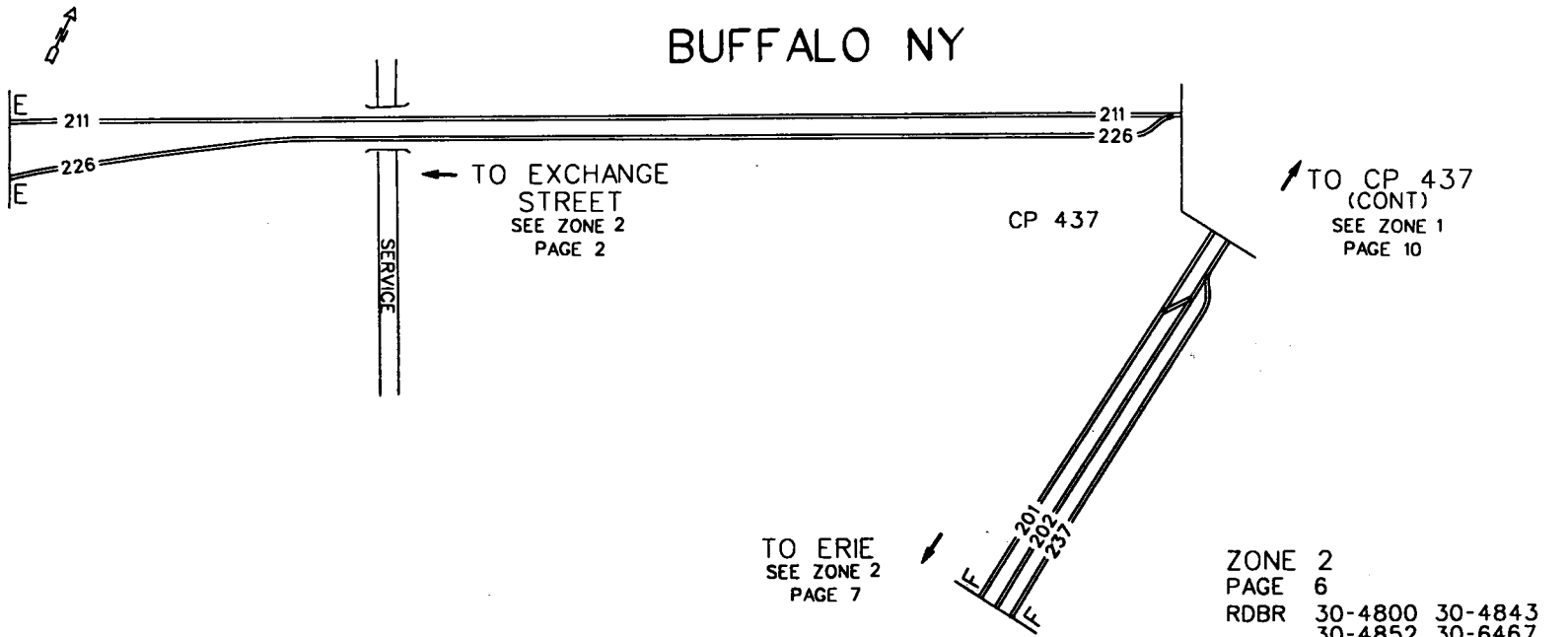

← TO EXCHANGE STREET  
SEE ZONE 2  
PAGE 2

↗ TO CP 437  
(CONT)  
SEE ZONE 1  
PAGE 10

↙ TO ERIE  
SEE ZONE 2  
PAGE 7

ZONE 2  
PAGE 6  
RDBR 30-4800 30-4843  
30-4852 30-6467  
DIVISION ALBANY  
REV 12-01-89

ZONE 2

Rev 12/23/96

PAGE 7

|   |     |    |    |                         |
|---|-----|----|----|-------------------------|
| 2 | 201 | 00 | 00 | Chicago - Line - Tk.#1  |
| 2 | 202 | 00 | 00 | Chicago - Line - Tk.#2  |
| 2 | 220 | 00 | 00 | Ebenezer - Secondary    |
| 2 | 232 | 00 | 00 | Babcock St Yd Tk.#2     |
| 2 | 234 | 00 | 00 | Babcock St Yd Tk.#4     |
| 2 | 237 | 00 | 00 | Howard St. Running      |
| 2 | 244 | 00 | 00 | Bison - Running         |
| 2 | 246 | 00 | 00 | Transco Wye - Tk.       |
| 2 | 630 | 00 | 00 | (NS) - Connection - Tk. |
| 2 | 770 | 99 | 99 | Laub Whse. Lead         |
| 2 | 771 | 01 | 05 | Laub Whse. Tk.#1        |
| 2 | 772 | 99 | 99 | Laub Whse. Tk.#2        |

# BUFFALO NY

CLINTON STREET X-OVERS

TO CP 437  
SEE ZONE 2  
PAGE 6

TO WILLIAM STREET &  
SO. TIER LINE  
SEE ZONE 2  
PAGE 8

TO CP GJ  
SEE ZONE 3  
PAGE 4

TO CP DRAW  
SEE ZONE 2  
PAGE 9

ZONE 2  
PAGE 7  
RDBR 30-4814 30-4852  
30-6401 30-6467  
DIVISION ALBANY  
REV 03-19-96

40A

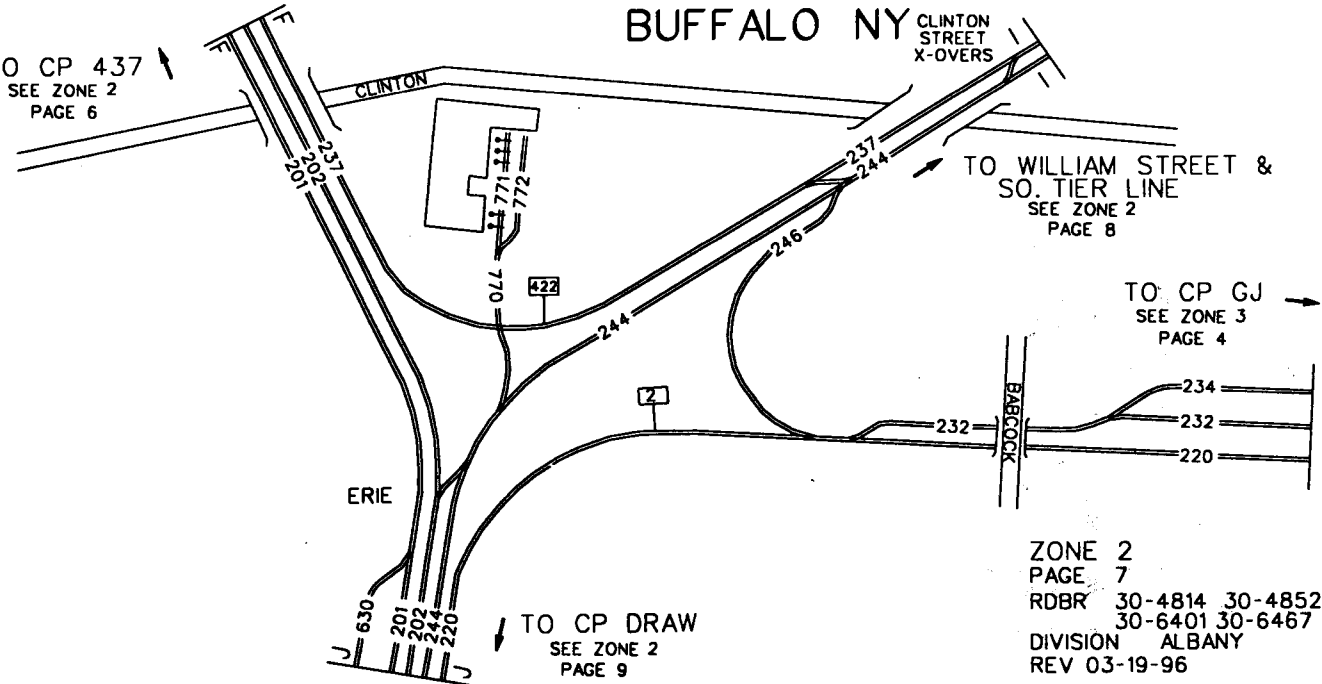

ZONE 2

Rev 12/20/96

PAGE 8

2 237 00 00 Howard St. Running  
2 244 00 00 Bison - Running  
2 245 00 00 Tk.#3 - Freight Main  
2 648 00 00 (D&H) - Connection - Tk.  
2 649 00 00 (D&H) - Connection - Tk.  
2 650 00 00 (D&H) - Connection - Tk.

BUFFALO NY

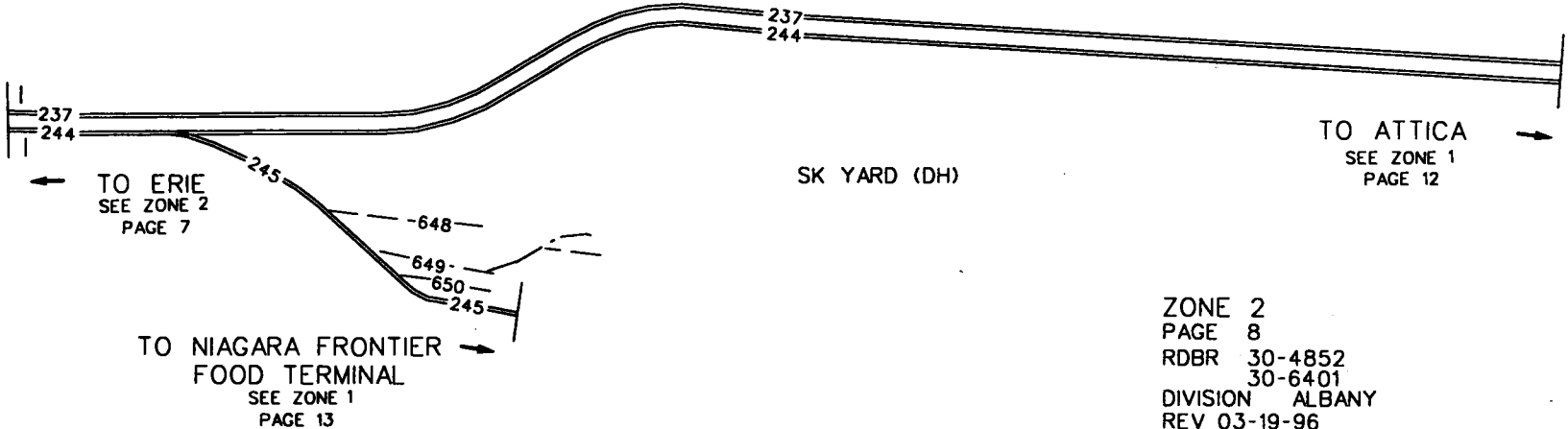

ZONE 2  
 PAGE 8  
 RDBR 30-4852  
 30-6401  
 DIVISION ALBANY  
 REV 03-19-96

ZONE 2

Rev 12/20/96

PAGE 9

2 201 00 00 Chicago - Line - Tk.#1  
2 202 00 00 Chicago - Line - Tk.#2  
2 220 00 00 Ebenezer - Secondary  
2 244 00 00 Bison - Running  
2 249 00 00 Prenatt St. Lead - (Atlas Main)  
2 253 00 00 Abby - Yd. Lead  
2 629 00 00 (SB) - Connection - Tk.  
2 630 00 00 (NS) - Connection - Tk.  
2 640 00 00 (NS) - Connection - Tk.  
2 657 00 00 (BPRR) - Connection - Tk.  
2 673 00 00 Abby - Yd. Tk.#3  
2 674 00 00 Abby - Yd. Tk.#4  
2 778 01 02 Buffalo Color - Tk.#20

# BUFFALO NY

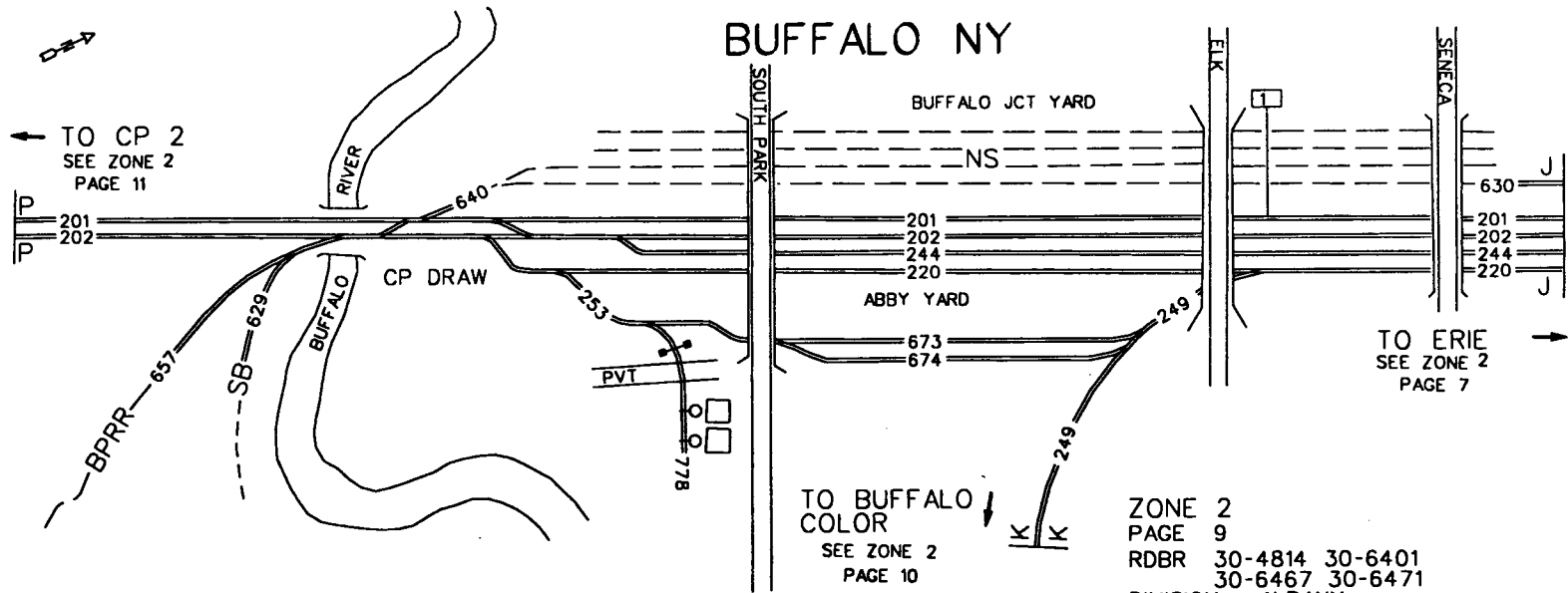

ZONE 2  
PAGE 9  
RDBR 30-4814 30-6401  
30-6467 30-6471  
DIVISION ALBANY  
REV 03-19-96



ZONE 2

Rev 12/20/96

PAGE 10

2 249 00 00 Prenatt St. Lead - (Atlas Main)  
2 250 00 00 Ind. Lead - Tk.  
2 251 00 00 Industrial Lead  
2 775 01 06 Buffalo Color - Liberty Park North Tk.  
2 776 01 01 Buffalo Color - Liberty Park South Tk.  
2 777 99 99 Buffalo Color - Storage Tk.  
2 780 99 99 PVS Chemical  
2 781 01 01 PVS Chemical - Tk.  
2 782 01 01 PVS Chemical - Tk.  
2 783 99 99 PVS Chemical - Stg. Tk.#3  
2 784 01 02 PVS Chemical - Tk.  
2 785 01 01 PVS Chemical - Tk.#5  
2 786 01 04 PVS Chemical - Tk.#6  
2 787 01 01 PVS Chemical - Sulphur Tk.  
2 788 01 02 PVS Chemical - Tk.  
2 789 99 99 PVS Chemical - Field Tk.  
2 790 01 01 PVS Chemical

# BUFFALO NY

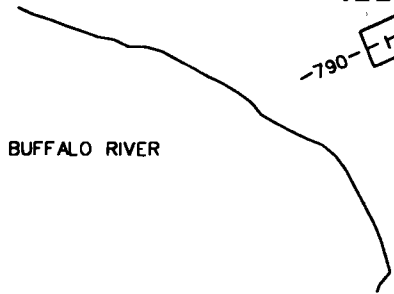
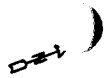

BUFFALO RIVER

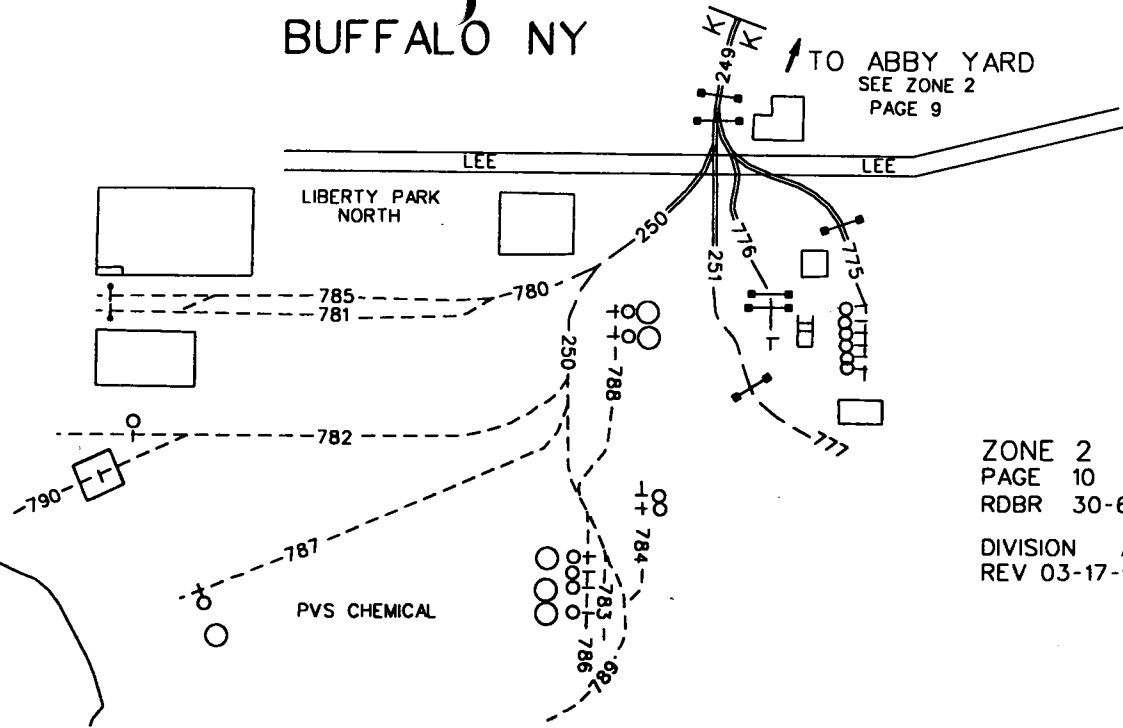

ZONE 2  
PAGE 10  
RDBR 30-6471  
DIVISION ALBANY  
REV 03-17-96

ZONE 2

Rev 12/20/96

PAGE 11

2 201 00 00 Chicago - Line - Tk.#1  
2 202 00 00 Chicago - Line - Tk.#2  
2 203 00 00 Chicago - Line - Tk.#3  
2 226 00 00 Compromise - Branch  
2 257 00 00 Eastbound  
2 258 00 00 Beach Lead - (Former Bck ML)  
2 259 00 00 Lehigh Connection  
2 260 00 00 Ohio St. Connection  
2 261 00 00 River - Tk.  
2 262 00 00 Middle - Yd. Lead  
2 631 00 00 Lehigh - Tk.#17  
2 632 00 00 Tk.#2 - In The Flats  
2 633 00 00 Lehigh West Bound Main  
2 659 00 00 (NS) - Connection - Tk.  
2 660 00 00 (NS) - Connection - Tk.  
2 682 00 00 (BSOR) - I/C - Tk.  
2 683 00 00 (BSOR) - I/C - Tk.

# BUFFALO NY

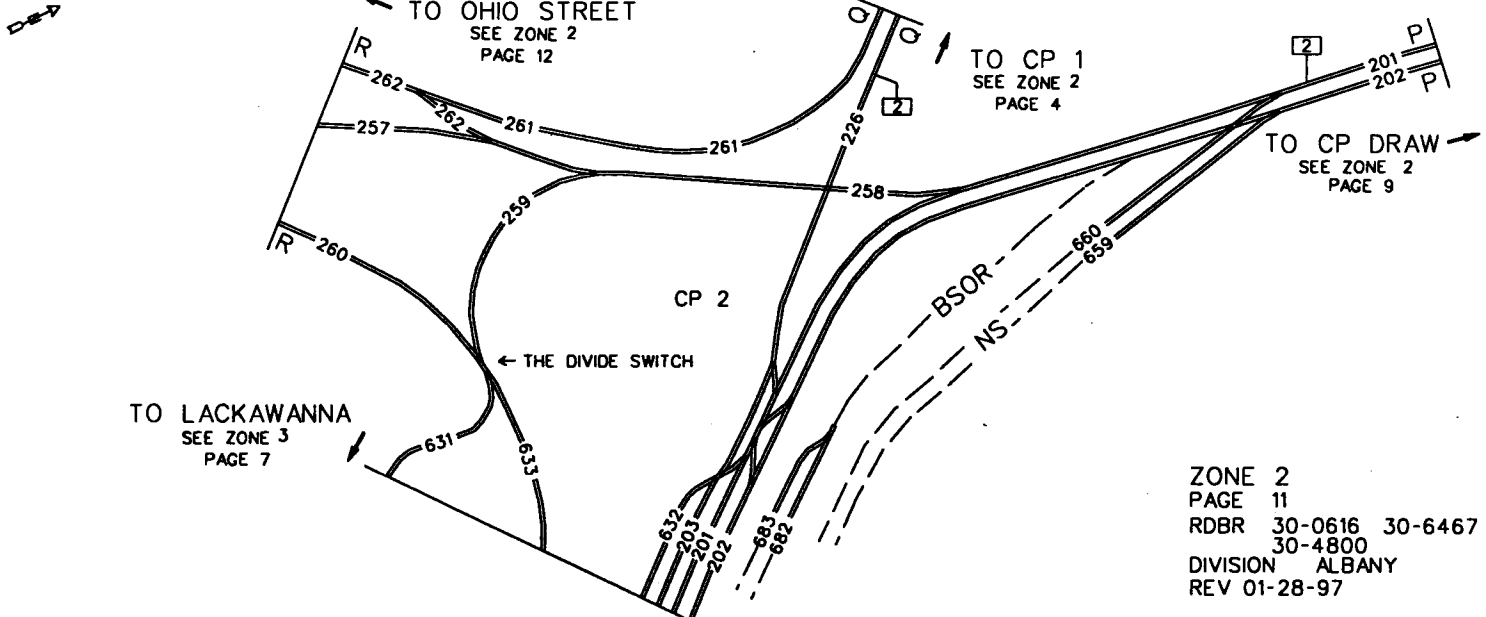

ZONE 2  
PAGE 11  
RDBR 30-0616 30-6467  
30-4800  
DIVISION ALBANY  
REV 01-28-97

- 2 254 00 00 Pocket
- 2 256 00 00 Pocket
- 2 257 00 00 Eastbound
- 2 260 00 00 Ohio St. Connection
- 2 262 00 00 Middle - Yd. Lead
- 2 263 00 00 W.bnd - Main - (Former Bck)
- 2 601 00 00 Ohio St. Middle - Yd. Tk.#1
- 2 602 00 00 Ohio St. Middle - Yd. Tk.#2
- 2 603 00 00 Ohio St. Middle - Yd. Tk.#3
- 2 604 00 00 Ohio St. Middle - Yd. Tk.#4
- 2 605 00 00 Ohio St. Middle - Yd. Tk.#5
- 2 606 00 00 Ohio St. Middle - Yd. Tk.#6
- 2 607 00 00 Ohio St. Middle - Yd. Tk.#7
- 2 608 00 00 Ohio St. Middle - Yd. Tk.#8
- 2 609 00 00 Ohio St. Middle - Yd. Tk.#9
- 2 610 00 00 Ohio St. Middle - Yd. Tk.#10
- 2 611 00 00 Ohio St. Middle - Yd. Tk.#11
- 2 612 00 00 Ohio St. Middle - Yd. Tk.#12
- 2 613 00 00 Ohio St. Middle - Yd. Tk.#13
- 2 614 00 00 Ohio St. Middle - Yd. Tk.#14
- 2 615 00 00 Ohio St. Middle - Yd. Tk.#15

# BUFFALO NY



## OHIO STREET MIDDLE YARD

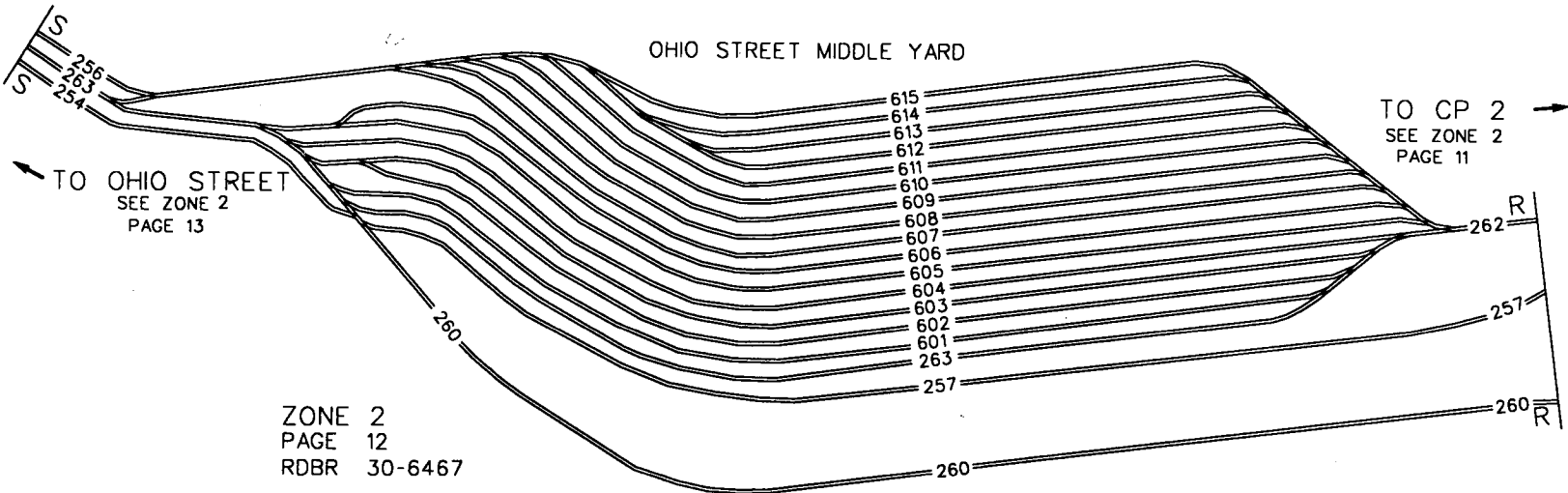

TO OHIO STREET  
SEE ZONE 2  
PAGE 13

TO CP 2  
SEE ZONE 2  
PAGE 11

ZONE 2  
PAGE 12  
RDBR 30-6467  
DIVISION ALBANY  
REV 03-19-96

ZONE 2

Rev 12/23/96

PAGE 13

|   |     |    |    |                              |
|---|-----|----|----|------------------------------|
| 2 | 254 | 00 | 00 | Pocket                       |
| 2 | 256 | 00 | 00 | Pocket                       |
| 2 | 263 | 00 | 00 | W.bnd - Main - (Former Bck)  |
| 2 | 264 | 00 | 00 | Ohio St. Yd. Lead            |
| 2 | 265 | 00 | 00 | Advance - Tk.#2              |
| 2 | 267 | 00 | 00 | Burrows Lot - Yd. Lead       |
| 2 | 280 | 00 | 00 | Beach - Lead                 |
| 2 | 281 | 00 | 00 | Beach - Tk.#1                |
| 2 | 282 | 00 | 00 | Beach - Tk.#2                |
| 2 | 286 | 00 | 00 | Beach - W.bnd - Lead - Tk.#6 |
| 2 | 290 | 00 | 00 | Ind. Lead - Tk.              |
| 2 | 533 | 00 | 00 | Beach - Tk.#3                |
| 2 | 534 | 00 | 00 | Beach - Tk.#4                |
| 2 | 921 | 99 | 99 | NFTA                         |
| 2 | 925 | 01 | 02 | Rich Tank Farm               |

# BUFFALO NY

ZONE 2  
PAGE 13  
RDBR 30-6467  
30-6472  
DIVISION ALBANY  
REV 03-19-96

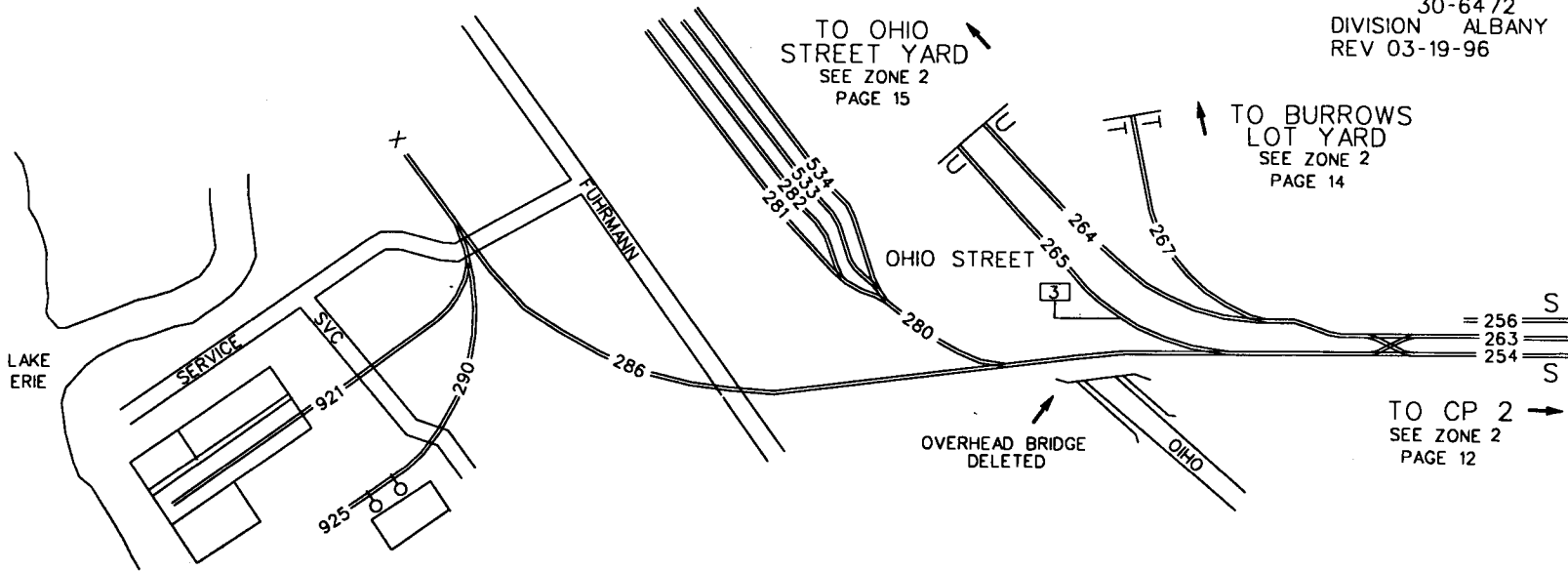

LAKE  
ERIE

SERVICE

SVC

FURMAN

OHIO STREET

TO BURROWS  
LOT YARD

TO OHIO  
STREET YARD

TO CP 2

OVERHEAD BRIDGE  
DELETED

OHIO



2 267 00 00 Burrows Lot - Yd. Lead  
2 268 00 00 Schwartz - Lead (Leased by Conagra)  
2 269 00 00 Marine - Lead (Leased by Conagra)  
2 621 00 00 Burrows Lot - Yd. Tk.#1 (Leased)  
2 622 00 00 Burrows Lot - Yd. Tk.#2 (Leased)  
2 623 00 00 Burrows Lot - Yd. Tk.#3 (Leased)  
2 624 00 00 Burrows Lot - Yd. Tk.#4 (Leased)  
2 625 00 00 Burrows Lot - Yd. Tk.#5 (Leased)  
2 626 00 00 Burrows Lot - Yd. Tk.#6 (Leased)  
2 627 00 00 Burrows Lot - Yd. Tk.#7 (Leased)  
2 628 00 00 Burrows Lot - Yd. Tk.#8 (Leased)  
2 635 00 00 Burrows Lot - Electric - Tk.#5 (Leased)  
2 636 00 00 Burrows Lot - Electric - Tk.#6 (Leased)  
2 641 00 00 Burrows Lot - Yd. Field - Tk.#1  
2 642 00 00 Burrows Lot - Yd. Field - Tk.#2  
2 643 00 00 Burrows Lot - Yd. Field - Tk.#3  
2 818 99 99 Co-Steel Recycling Advance Division  
2 821 99 99 Conagra Tk.#1 (Leased)  
2 822 01 03 Conagra Tk.#2 (Leased)  
2 831 99 99 Conagra - Tk.#1 (Leased)  
2 832 99 99 Conagra - Tk.#2 (Leased)  
2 833 01 02 Conagra - Tk.#3 (Leased)  
2 834 01 03 Conagra - Tk.#4 (Leased)  
2 835 01 01 Conagra - Tk.#5 (Leased)  
2 836 01 01 Conagra - Tk.#6 (Leased)  
2 841 01 02 American Malting - Tk.#1 (Leased)  
2 842 01 02 American Malting - Tk.#2 (Leased)  
2 851 01 03 Conagra - Tk.#1 (Leased)  
2 852 01 03 Conagra - Tk.#2 (Leased)  
2 853 01 05 Conagra - Tk.#3 (Leased)  
2 854 99 99 Conagra - Tk.#4 (Leased)  
2 855 01 03 Conagra - Tk.#5 (Leased)  
2 856 01 03 Conagra - Tk.#6 (Leased)  
2 857 01 03 Conagra - Tk.#7 (Leased)  
2 858 01 06 Conagra - Tk.#8 (Leased)

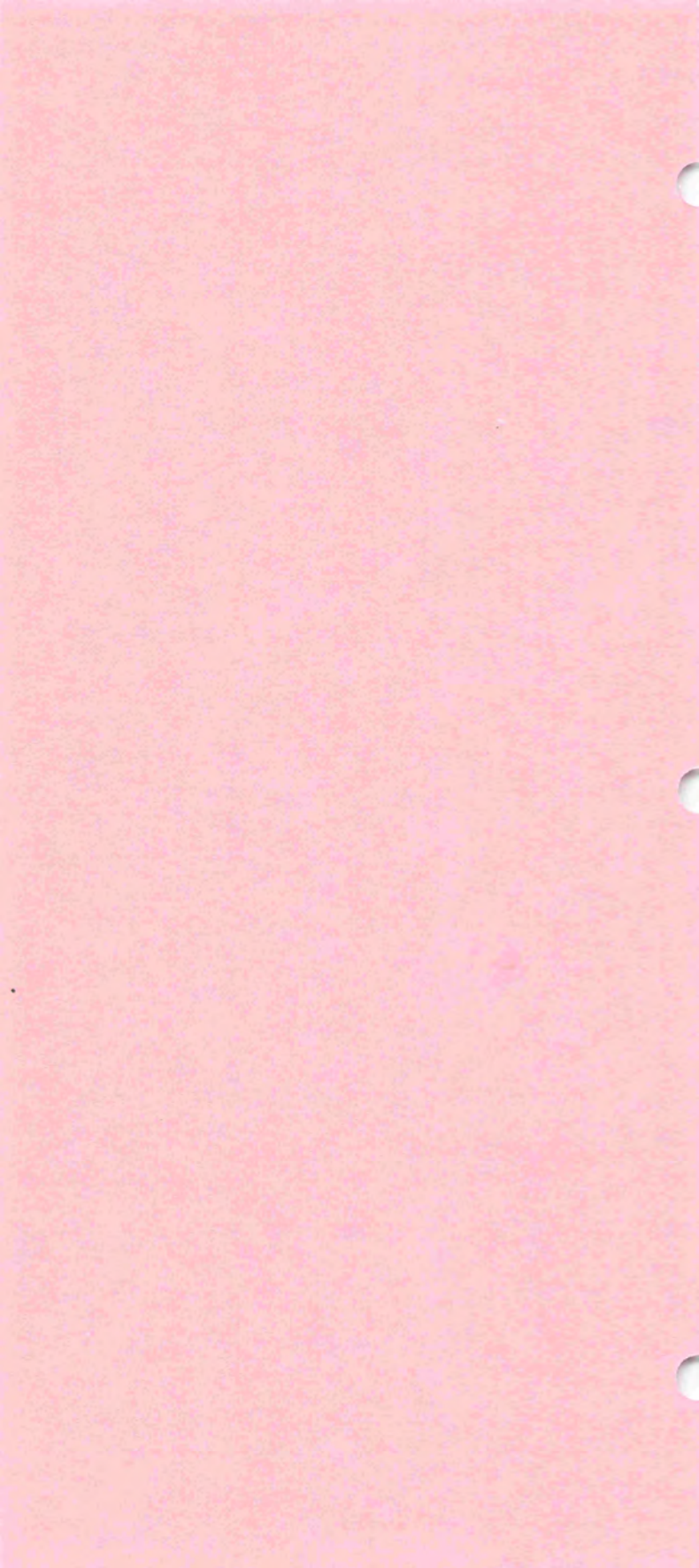

ZONE 2

Rev 12/20/96

PAGE 15

|   |     |    |    |                              |
|---|-----|----|----|------------------------------|
| 2 | 264 | 00 | 00 | Ohio St. Yd. Lead            |
| 2 | 265 | 00 | 00 | Advance - Tk.#2              |
| 2 | 266 | 00 | 00 | Vulkey - Lead                |
| 2 | 272 | 00 | 00 | Tk.#2 - Main - (Former Bck)  |
| 2 | 273 | 00 | 00 | Top Vulkey                   |
| 2 | 274 | 00 | 00 | Lower Vulkey                 |
| 2 | 653 | 00 | 00 | Ohio St. Yd. Tumpike - Tk.#3 |
| 2 | 654 | 00 | 00 | Ohio St. Yd. Tumpike - Tk.#4 |
| 2 | 655 | 00 | 00 | Ohio St. Yd. Tumpike - Tk.#5 |
| 2 | 664 | 00 | 00 | Ohio St. Yd. E.bnd - Tk.#4   |
| 2 | 671 | 00 | 00 | Ohio St. Yd. E.bnd - Tk.#11  |
| 2 | 871 | 01 | 09 | ADM Milling - Tk.#1          |
| 2 | 872 | 99 | 99 | ADM Milling - Tk.#2          |
| 2 | 873 | 99 | 99 | ADM Milling - Tk.#3          |
| 2 | 874 | 99 | 99 | ADM Milling - Mutual - Tk.#4 |
| 2 | 875 | 01 | 01 | ADM Milling - Mutual - Tk.#5 |
| 2 | 876 | 01 | 01 | ADM Milling - Mutual - Tk.#6 |
| 2 | 877 | 01 | 01 | ADM Milling - Mutual - Tk.#7 |

# BUFFALO NY

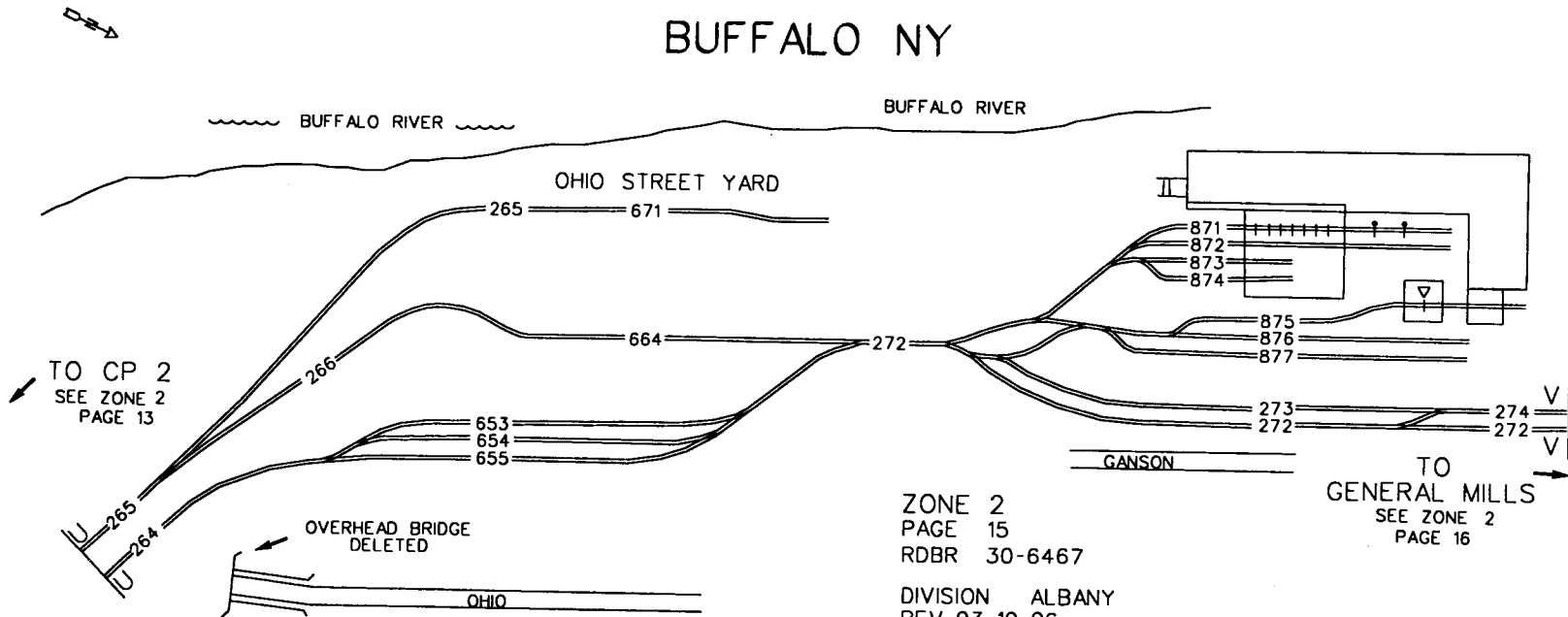

ZONE 2  
PAGE 15  
RDBR 30-6467

DIVISION ALBANY  
REV 03-19-96

ZONE 2

Rev 12/20/96

PAGE 16

|   |     |    |    |                                     |
|---|-----|----|----|-------------------------------------|
| 2 | 256 | 00 | 00 | Pocket                              |
| 2 | 272 | 00 | 00 | Tk.#2 - Main - (Former Bck)         |
| 2 | 274 | 00 | 00 | Lower Vulkey                        |
| 2 | 880 | 99 | 99 | General Mills - (BPRR) (Leased Tk.) |
| 2 | 881 | 99 | 99 | General Mills - Whse. Tk.#1         |
| 2 | 882 | 01 | 03 | General Mills - Mill - Tk.#2        |
| 2 | 885 | 99 | 99 | General Mills - Mill - Tk.#5        |
| 2 | 887 | 01 | 01 | General Mills - Mill - Tk.#7        |
| 2 | 891 | 99 | 99 | General Mills - Cereal - Tk.#1      |
| 2 | 892 | 99 | 99 | General Mills - Cereal - Tk.#2      |
| 2 | 897 | 99 | 99 | General Mills - Cereal - Tk.#7      |
| 2 | 901 | 99 | 99 | General Mills - Grain - Tk.#1       |
| 2 | 902 | 01 | 01 | General Mills - Grain - Tk.#2       |
| 2 | 907 | 99 | 99 | Integrated Tire                     |
| 2 | 907 | 99 | 99 | Crown Lumber - Tk.#2                |

# BUFFALO NY

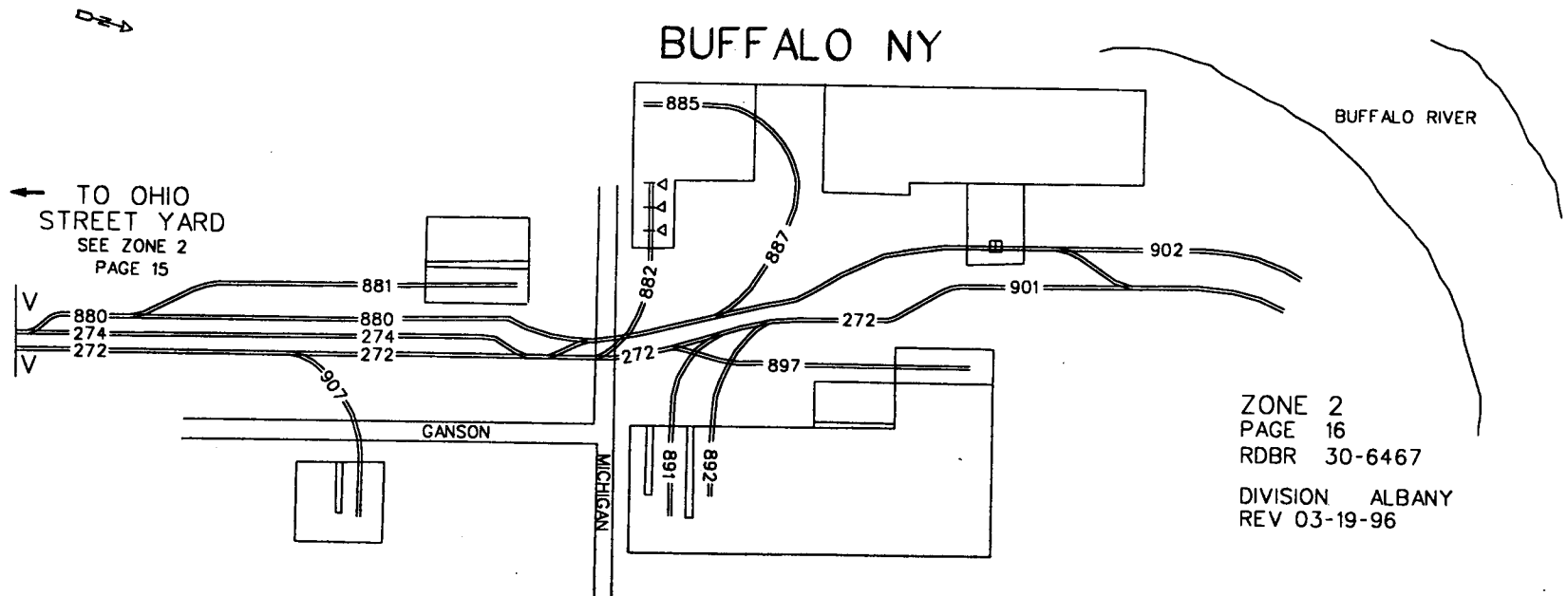

← TO OHIO STREET YARD  
SEE ZONE 2  
PAGE 15

BUFFALO RIVER

ZONE 2  
PAGE 16  
RDBR 30-6467  
DIVISION ALBANY  
REV 03-19-96

# SENECA-ZONE 3

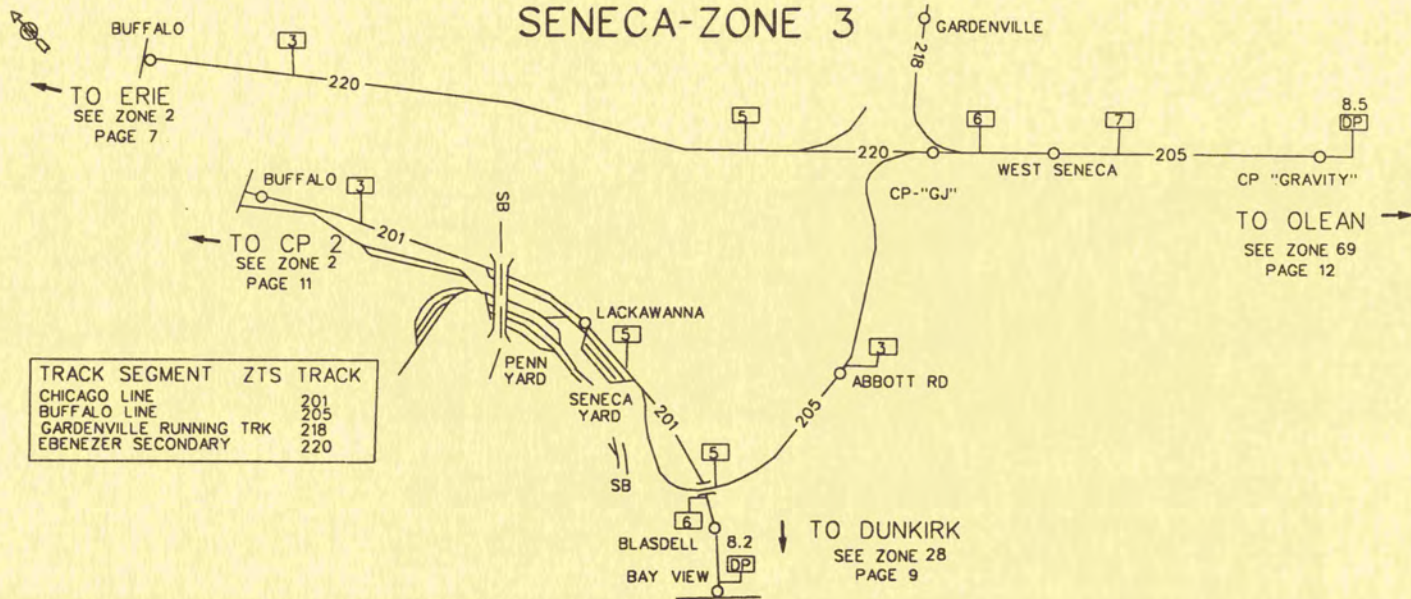

ZONE 3

Rev 12/10/96

PAGE 1

|   |     |    |    |                             |
|---|-----|----|----|-----------------------------|
| 3 | 205 | 00 | 00 | Buffalo - Line              |
| 3 | 208 | 00 | 00 | Controlled - Siding         |
| 3 | 211 | 00 | 00 | Ind. Lead - Tk.             |
| 3 | 213 | 00 | 00 | Crossover                   |
| 3 | 215 | 00 | 00 | Ind. Lead - Tk.             |
| 3 | 708 | 99 | 99 | Ebenezer Rail Car           |
| 3 | 710 | 99 | 99 | Eastern Railway - I/B - Tk. |
| 3 | 711 | 99 | 99 | Eastern Railway - O/B - Tk. |
| 3 | 714 | 01 | 07 | Sonwill Dist. Center - Tk.  |



# WEST SENECA NY

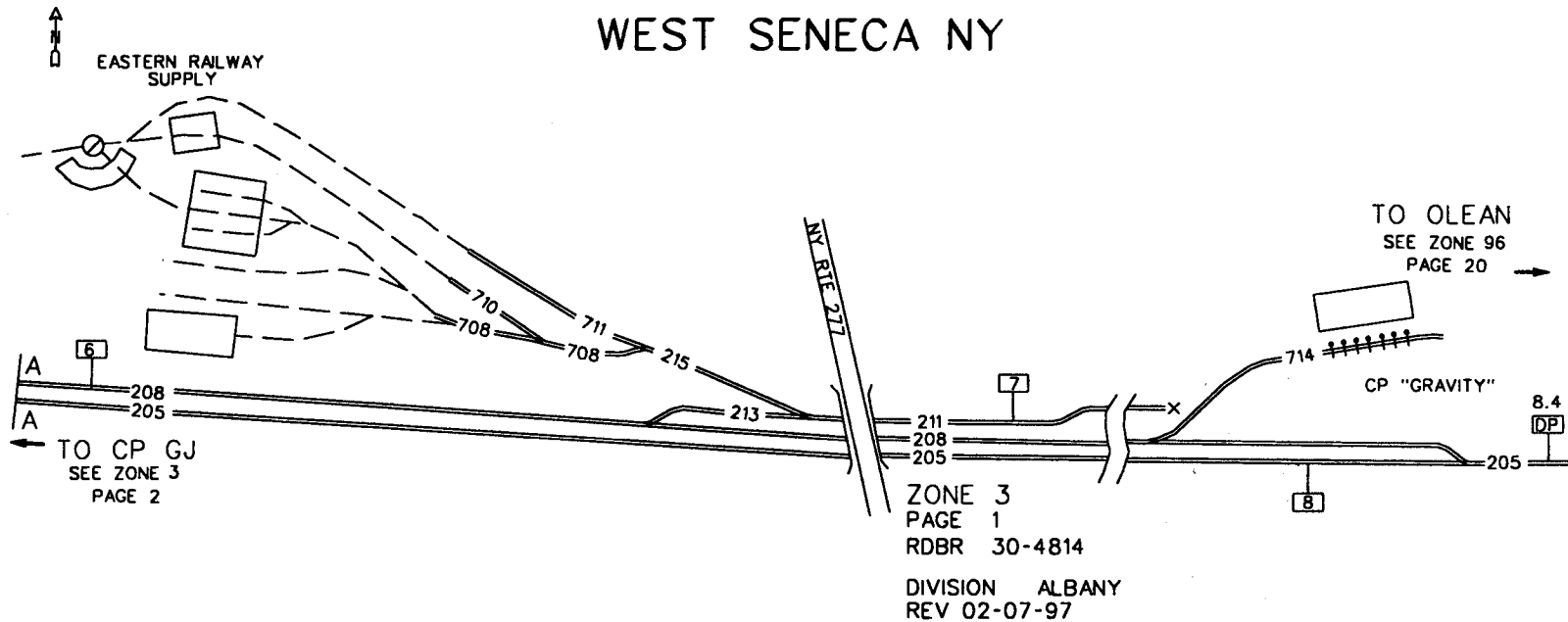

↑  
N  
EASTERN RAILWAY  
SUPPLY

TO OLEAN  
SEE ZONE 96  
PAGE 20 →

A 6  
208  
205  
← TO CP GJ  
SEE ZONE 3  
PAGE 2

211  
208  
205  
7  
X  
8  
8.4  
DP

ZONE 3  
PAGE 1  
RDBR 30-4814  
DIVISION ALBANY  
REV 02-07-97

8.4  
DP

ZONE 3

Rev 12/10/86

PAGE 2

|   |     |    |    |                                    |
|---|-----|----|----|------------------------------------|
| 3 | 205 | 00 | 00 | Buffalo - Line                     |
| 3 | 208 | 00 | 00 | Controlled - Siding                |
| 3 | 218 | 00 | 00 | Gardenville - Industrial - Tk.     |
| 3 | 220 | 00 | 00 | Ebenezer - Secondary               |
| 3 | 715 | 99 | 99 | Niagara Mohawk Power - New Station |
| 3 | 716 | 01 | 02 | Niagara Mohawk Power - Old Station |

# WEST SENECA NY

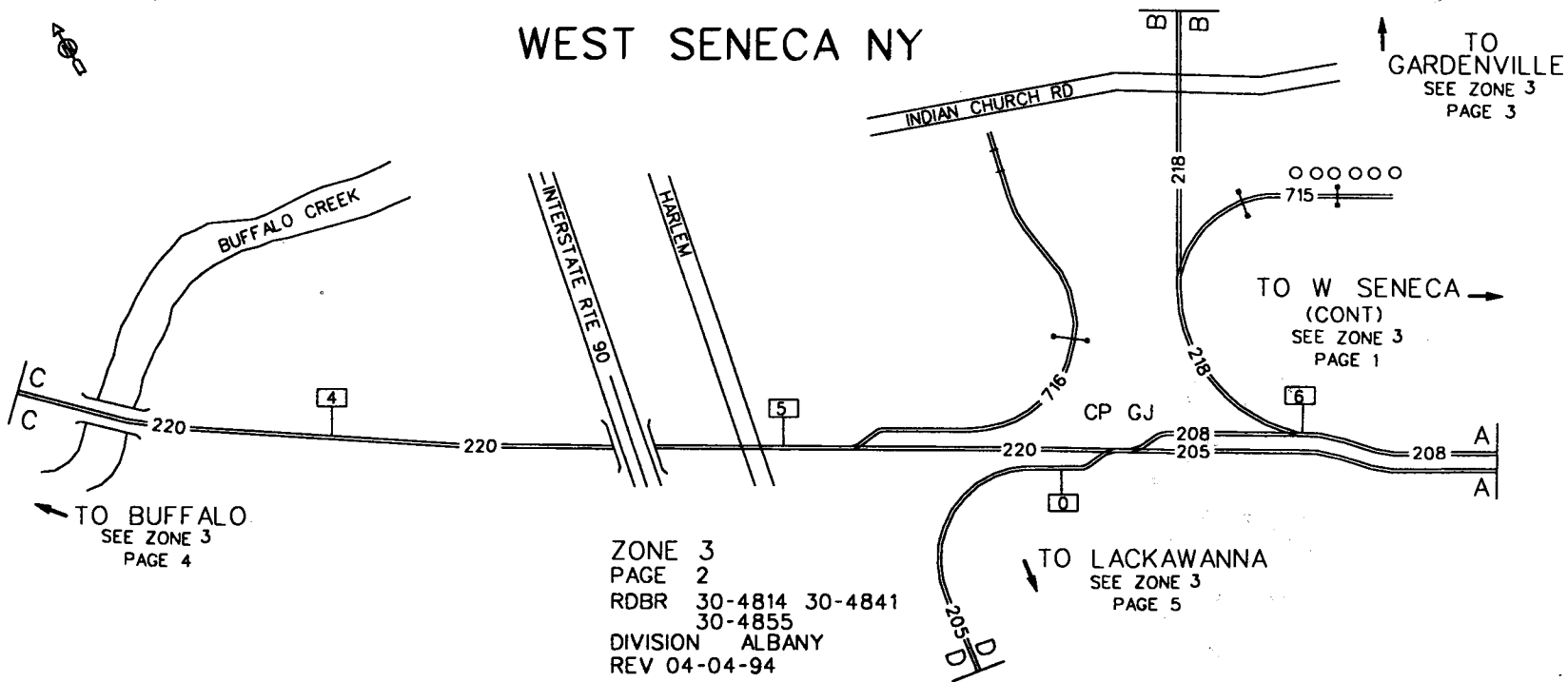

↑ TO GARDENVILLE  
SEE ZONE 3  
PAGE 3

TO W SENECA →  
(CONT)  
SEE ZONE 3  
PAGE 1

ZONE 3  
PAGE 2  
RDBR 30-4814 30-4841  
30-4855  
DIVISION ALBANY  
REV 04-04-94

↓ TO LACKAWANNA  
SEE ZONE 3  
PAGE 5

← TO BUFFALO  
SEE ZONE 3  
PAGE 4

**ZONE 3**

**Rev 12/10/96**

**PAGE 3**

- 3 218 00 00 Gardenville - Industrial - Tk.**
- 3 223 00 00 Ind. Lead - Tk.**
- 3 226 00 00 Runaround**
- 3 720 01 06 Monroe Palburn**
- 3 724 01 02 National Starch**
- 3 726 01 03 H.C.W.**

# WEST SENECA NY

# GARDENVILLE NY

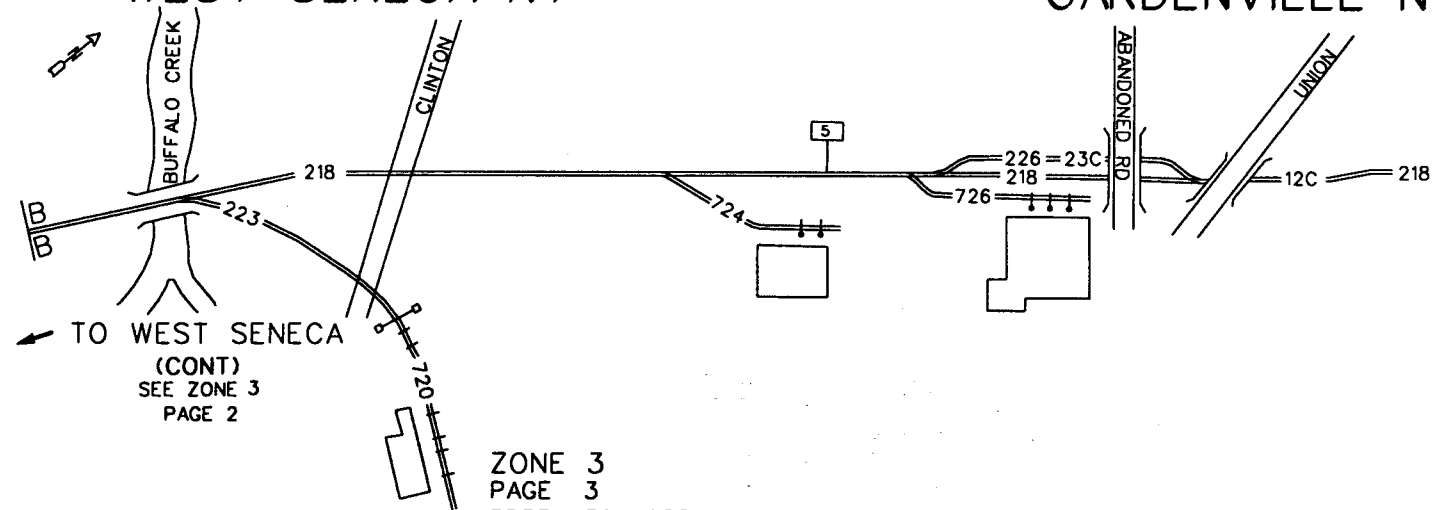

TO WEST SENECA  
(CONT)  
SEE ZONE 3  
PAGE 2

ZONE 3  
PAGE 3  
RDBR 30-4855  
DIVISION ALBANY  
REV 02-01-94

|   |     |    |    |                               |
|---|-----|----|----|-------------------------------|
| 3 | 220 | 00 | 00 | Ebenezer - Secondary          |
| 3 | 232 | 00 | 00 | Babcock St Yd Tk.#2           |
| 3 | 234 | 00 | 00 | Babcock St Yd Tk.#4           |
| 3 | 750 | 99 | 99 | Worthington - Tk.#0           |
| 3 | 751 | 99 | 99 | Worthington - Tk.#1           |
| 3 | 752 | 99 | 99 | Worthington - Tk.#2           |
| 3 | 753 | 99 | 99 | Worthington - Tk.#3           |
| 3 | 754 | 99 | 99 | Worthington - Tk.#4           |
| 3 | 755 | 99 | 99 | Worthington - Tk.#5           |
| 3 | 756 | 99 | 99 | Worthington - Lead            |
| 3 | 757 | 99 | 99 | Worthington - Foundry Tk.     |
| 3 | 758 | 99 | 99 | Worthington - Scrap Tk.       |
| 3 | 759 | 99 | 99 | Worthington - Scrap Tk.       |
| 3 | 760 | 99 | 99 | Worthington - Runaround       |
| 3 | 761 | 99 | 99 | Worthington - Lead            |
| 3 | 764 | 01 | 02 | Battenfield Oil               |
| 3 | 765 | 01 | 05 | Battenfield Oil Warehouse Tk. |
| 3 | 771 | 01 | 03 | Chapin & Fagin                |
| 3 | 776 | 01 | 03 | Vacant - Tk.#2                |
| 3 | 777 | 01 | 02 | Vacant - Tk.#1                |
| 3 | 779 | 01 | 02 | Buffalo China                 |

# BUFFALO NY

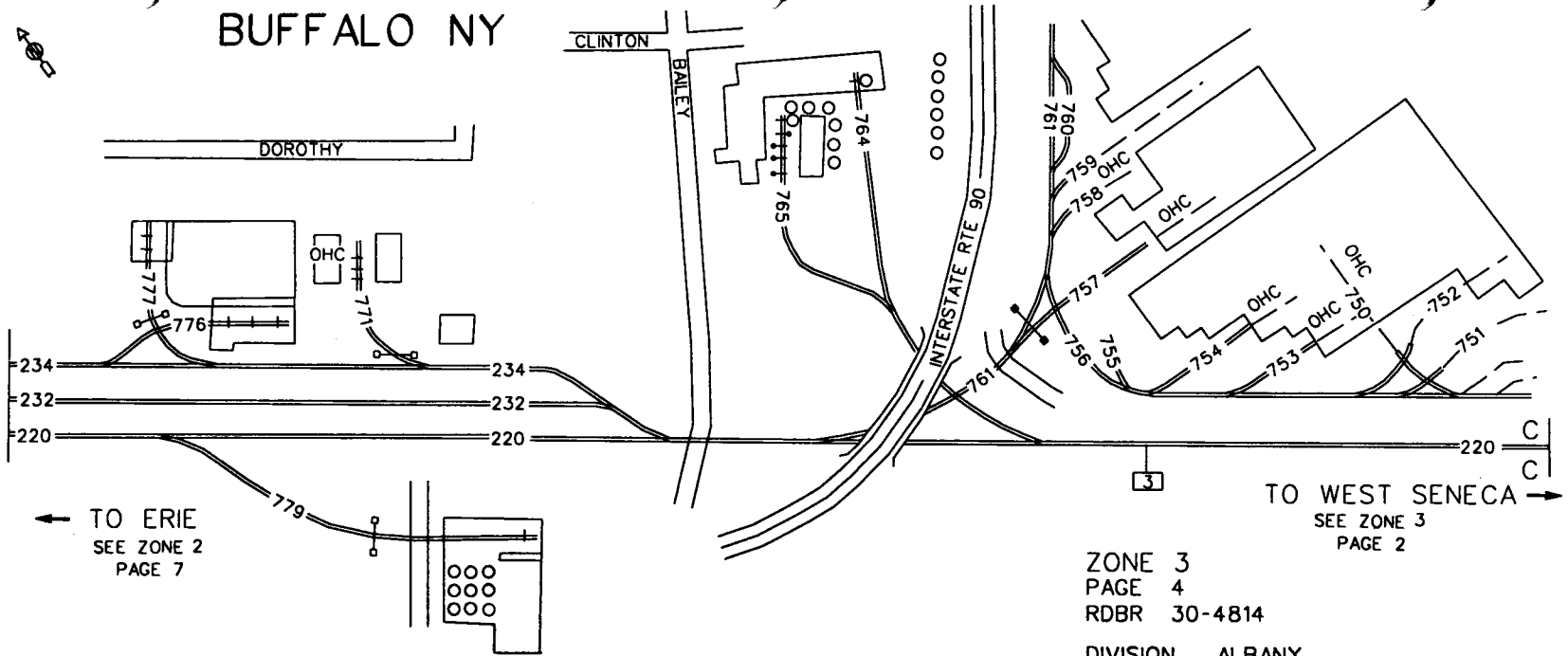

← TO ERIE  
SEE ZONE 2  
PAGE 7

TO WEST SENECA →  
SEE ZONE 3  
PAGE 2

ZONE 3  
PAGE 4  
RDBR 30-4814  
DIVISION ALBANY  
REV 02-01-94

ZONE 3

Rev 12/26/96

PAGE 5

|   |     |    |    |                                 |
|---|-----|----|----|---------------------------------|
| 3 | 201 | 00 | 00 | Chicago - Line - Tk.#1          |
| 3 | 202 | 00 | 00 | Chicago - Line - Tk.#2          |
| 3 | 203 | 00 | 00 | Chicago - Line - Tk.#3          |
| 3 | 204 | 00 | 00 | Old - Main - Tk.#4              |
| 3 | 205 | 00 | 00 | Buffalo - Line                  |
| 3 | 601 | 00 | 00 | (CR) - (H) Yd. Tk.#1 - O/B      |
| 3 | 602 | 00 | 00 | (CR) - (H) Yd. Tk.#2 - I/B      |
| 3 | 650 | 00 | 00 | (NS) - Connéction - Tk. Bayview |



BAYVIEW NY

BLASDELL NY

LACKAWANNA NY



TO DUNKIRK

SEE ZONE 28  
PAGE 9

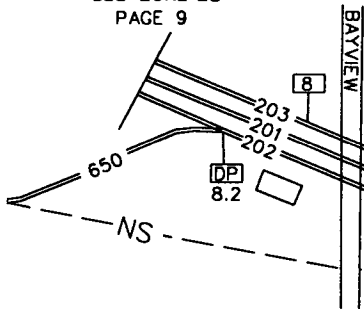

ZONE 3  
 PAGE 5  
 RDBR 30-4800  
 30-4853  
 DIVISION ALBANY  
 REV 05-05-94

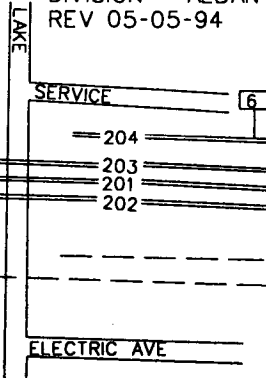

TO SENECA YARD

SEE ZONE 3  
PAGE 6



SB RY  
NOT ALL  
TRACKS SHOWN

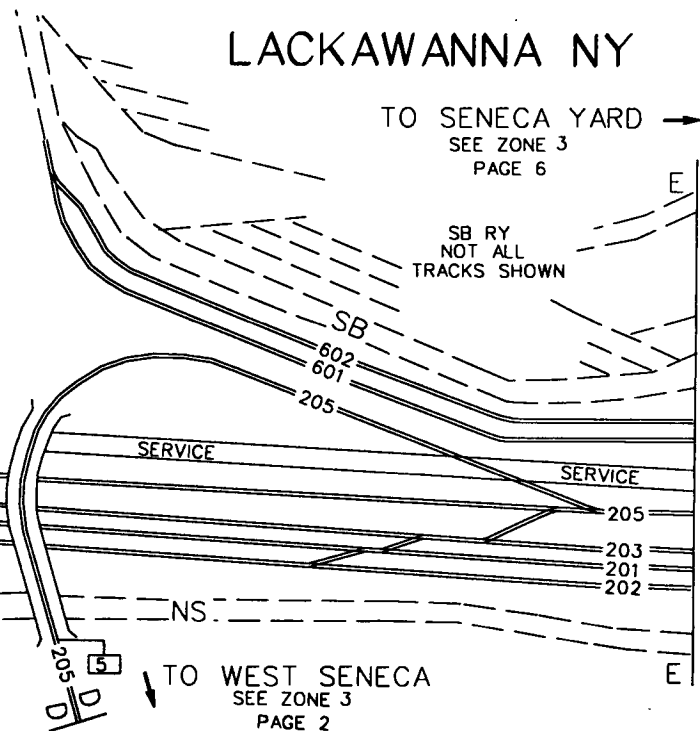

TO WEST SENECA  
 SEE ZONE 3  
 PAGE 2

3 001 00 00 Seneca - Class - Yd. Tk.#1  
3 002 00 00 Seneca - Class - Yd. Tk.#2  
3 003 00 00 Seneca - Class - Yd. Tk.#3  
3 004 00 00 Seneca - Class - Yd. Tk.#4  
3 005 00 00 Seneca - Class - Yd. Tk.#5  
3 006 00 00 Seneca - Class - Yd. Tk.#6  
3 007 00 00 Seneca - Class - Yd. Tk.#7  
3 008 00 00 Seneca - Class - Yd. Tk.#8  
3 009 00 00 Seneca - Class - Yd. Tk.#9  
3 010 00 00 Seneca - Class - Yd. Tk.#10  
3 011 00 00 Seneca - Class - Yd. Tk.#11  
3 012 00 00 Seneca - Class - Yd. Tk.#12  
3 013 00 00 Seneca - Class - Yd. Tk.#13  
3 014 00 00 Seneca - Class - Yd. Tk.#14  
3 015 00 00 Seneca - Class - Yd. Tk.#15  
3 016 00 00 Seneca - Class - Yd. Tk.#16  
3 017 00 00 Seneca - Class - Yd. Tk.#17  
3 018 00 00 Pocket - Tk.  
3 201 00 00 Chicago - Line - Tk.#1  
3 202 00 00 Chicago - Line - Tk.#2  
3 203 00 00 Chicago - Line - Tk.#3  
3 205 00 00 Buffalo - Line  
3 240 00 00 Crossover  
3 241 00 00 Crossover  
3 242 00 00 Crossover  
3 243 00 00 Bypass  
3 244 00 00 The New Track  
3 245 00 00 Drill - Tk.  
3 246 00 00 Cab Tk  
3 247 00 00 Class Lead  
3 250 00 00 Lead  
3 301 00 00 Rec. Tk.#1  
3 302 00 00 Rec. Tk.#2  
3 303 00 00 Rec. Tk.#3  
3 540 00 00 Tie Down - Tk.  
3 541 00 00 (Company Use Tk.)  
3 542 00 00 Equipment - Tk.  
3 543 00 00 Slag - Tk.  
3 601 00 00 (CR) - (H) Yd. Tk.#1 - O/B  
3 602 00 00 (CR) - (H) Yd. Tk.#2 - I/B  
3 603 00 00 (CR) - (H) Yd. Tk.  
3 610 00 00 (CR) - (H) Yd. Tk.  
3 611 00 00 #1 PS  
3 612 00 00 PS Lead

ZONE 3

Rev 12/10/96

PAGE 6 (continued)

- 3 621 00 00 Penn - Yd. Tk.#101
- 3 629 00 00 Penn - Yd. Upper - Tk.#319
- 3 630 00 00 Penn - Yd. Upper - Tk.#320
- 3 652 00 00 102 "100" Yard
- 3 653 00 00 103 "100" Yard
- 3 654 00 00 Shenandoah Lead

# LACKAWANNA NY (SENECA YARD)

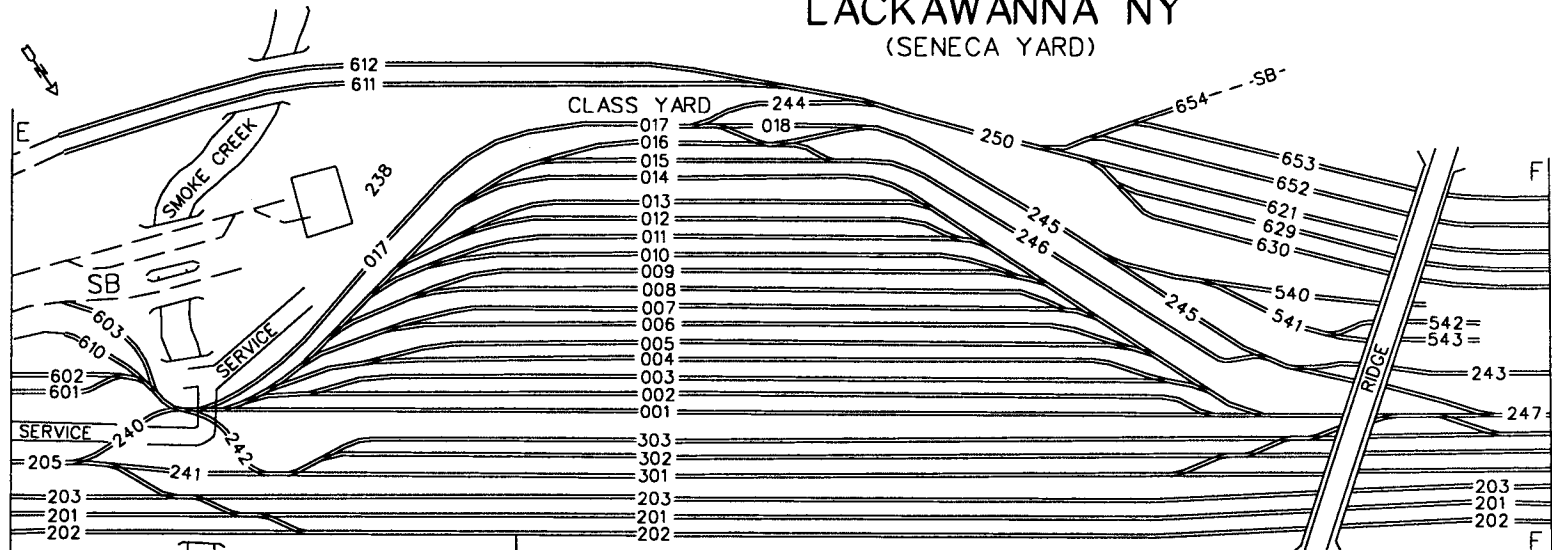

← TO DUNKIRK  
SEE ZONE 3  
PAGE 5

ZONE 3  
PAGE 6  
RDBR 30-4800  
30-4853  
DIVISION ALBANY  
REV 02-01-94

TO SENECA YARD →  
(CONT)  
SEE ZONE 3  
PAGE 7

|   |     |    |    |                                  |
|---|-----|----|----|----------------------------------|
| 3 | 201 | 00 | 00 | Chicago - Line - Tk.#1           |
| 3 | 202 | 00 | 00 | Chicago - Line - Tk.#2           |
| 3 | 203 | 00 | 00 | Chicago - Line - Tk.#3           |
| 3 | 243 | 00 | 00 | Bypass                           |
| 3 | 247 | 00 | 00 | Class Lead                       |
| 3 | 251 | 00 | 00 | Penn - Yd. Connection - Tk.      |
| 3 | 301 | 00 | 00 | Rec. Tk.#1                       |
| 3 | 302 | 00 | 00 | Rec. Tk.#2                       |
| 3 | 303 | 00 | 00 | Rec. Tk.#3                       |
| 3 | 621 | 00 | 00 | Penn - Yd. Tk.#101               |
| 3 | 629 | 00 | 00 | Penn - Yd. Upper - Tk.#319       |
| 3 | 630 | 00 | 00 | Penn - Yd. Upper - Tk.#320       |
| 3 | 631 | 00 | 00 | Lehigh - Tk.#17                  |
| 3 | 632 | 00 | 00 | Flats - Tk.#2 In                 |
| 3 | 633 | 00 | 00 | Lehigh Westbound Track           |
| 3 | 636 | 00 | 00 | Penn - Yd. Tk.#206               |
| 3 | 637 | 00 | 00 | Penn - Yd. Tk.#207               |
| 3 | 638 | 00 | 00 | Penn - Yd. Tk.#208               |
| 3 | 640 | 00 | 00 | Penn - Yd. Tk.#210               |
| 3 | 641 | 00 | 00 | Penn - Yd. Tk.#211               |
| 3 | 642 | 00 | 00 | Penn - Yd. Tk.#212               |
| 3 | 643 | 00 | 00 | Penn - Yd. Tk.#213               |
| 3 | 648 | 00 | 00 | Penn - Yd. Lower - Tk.#320       |
| 3 | 649 | 00 | 00 | Lower - Tk.#319                  |
| 3 | 652 | 00 | 00 | 102 "100" Yard                   |
| 3 | 653 | 00 | 00 | 103 "100" Yard                   |
| 3 | 781 | 01 | 06 | Independent Cement Inbound Loads |
| 3 | 782 | 01 | 06 | Independent Cement Outbound Mtys |

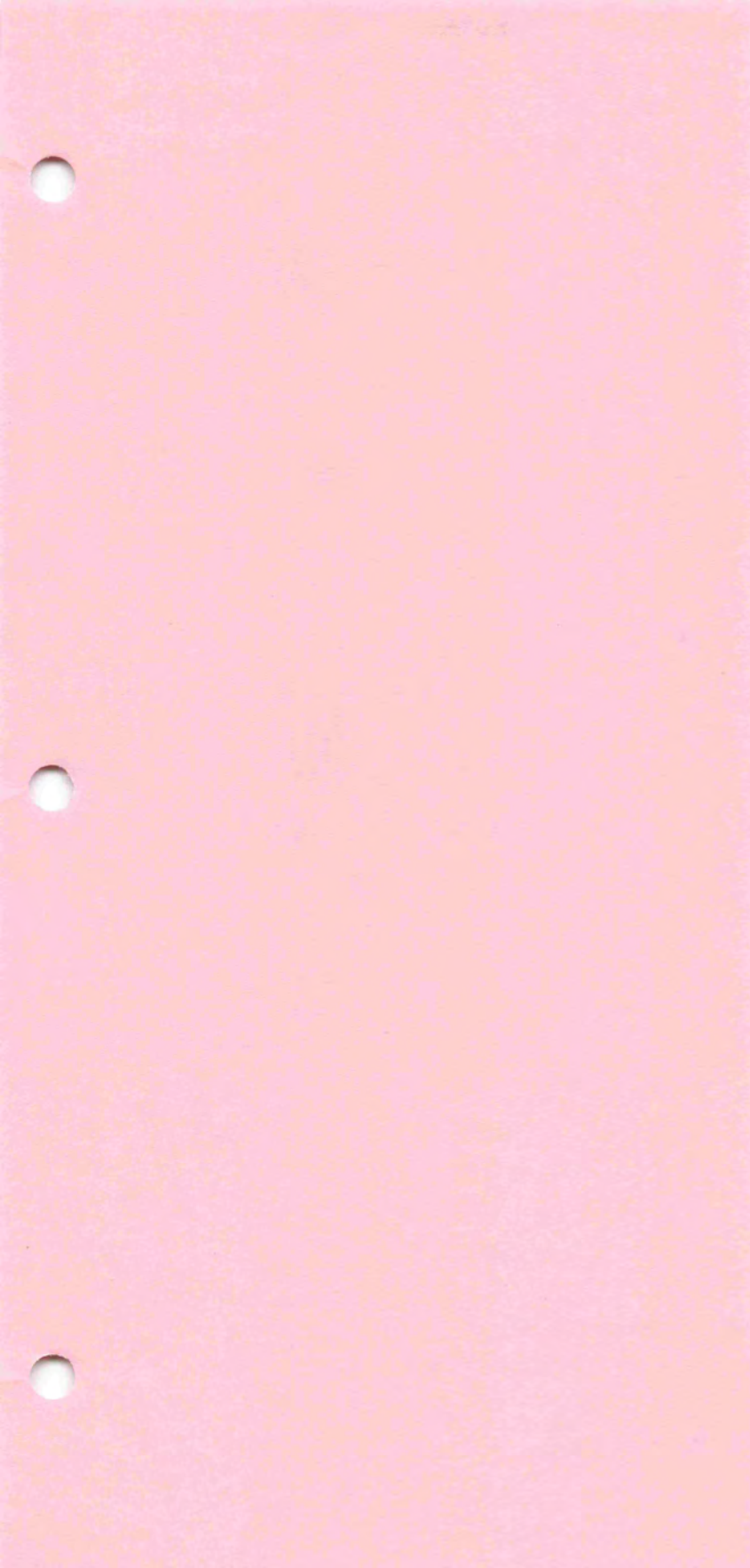



| TRACK SEGMENT            | ZTS TRK |
|--------------------------|---------|
| NIAGARA BRANCH           | 211     |
| LOCKPORT RUNNING TRACK   | 214     |
| WURLITZER INDUSTRIAL     | 219     |
| ERIE INDUSTRIAL          | 229     |
| TONAWANDA INDUSTRIAL     | 237     |
| WONALANCET RUNNING TRACK | 251     |
| BLACK ROCK INDUSTRIAL    | 281     |
| BELT LINE BRANCH         | 291     |

# KENMORE-ZONE 4

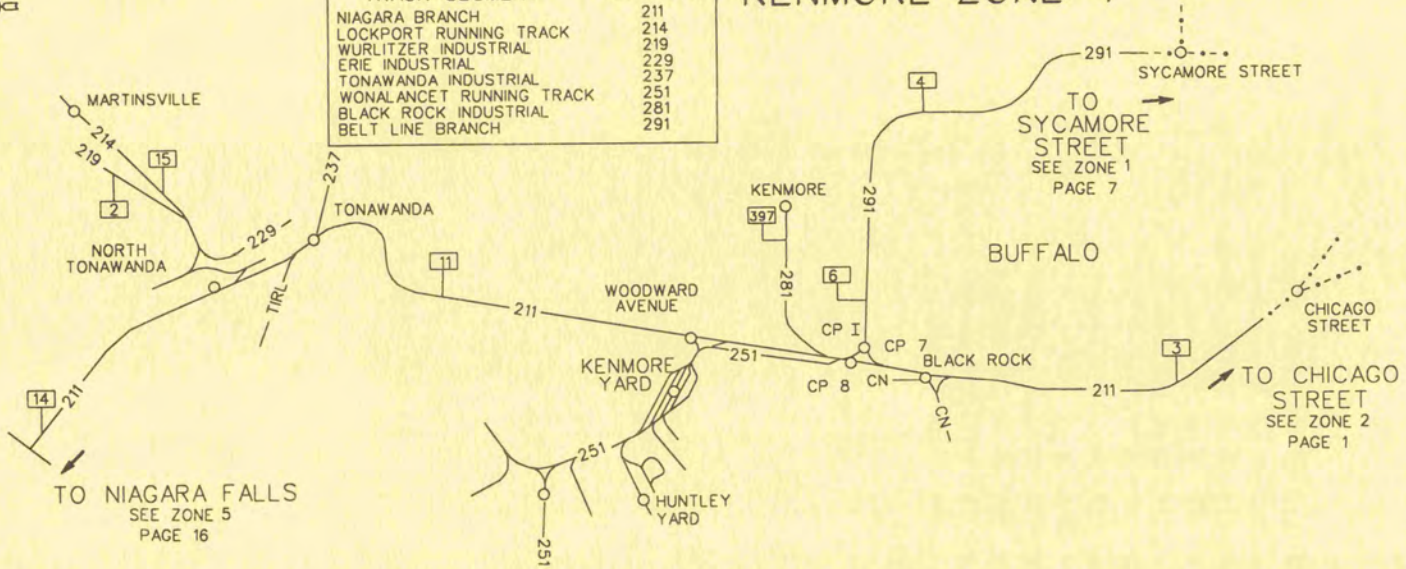

ZONE 4

Rev 12/23/96

PAGE 1

|   |     |    |    |                          |
|---|-----|----|----|--------------------------|
| 4 | 211 | 00 | 00 | Niagara - Branch - Tk.#1 |
| 4 | 212 | 00 | 00 | Niagara - Branch - Tk.#2 |
| 4 | 214 | 00 | 00 | Lockport - Running - Tk. |
| 4 | 216 | 00 | 00 | Crossover                |
| 4 | 217 | 00 | 00 | Ind. Lead - Tk.          |
| 4 | 218 | 00 | 00 | Lead                     |
| 4 | 227 | 00 | 00 | Wye Track                |
| 4 | 228 | 00 | 00 | Wye Tk.                  |
| 4 | 229 | 00 | 00 | Erie Industrial          |
| 4 | 231 | 00 | 00 | Erie Industrial          |
| 4 | 759 | 01 | 03 | Chesapeake Packaging     |
| 4 | 761 | 01 | 01 | Tondisco                 |



# NORTH TONAWANDA NY

ZONE 4

PAGE 1

RDBR 30-4843 30-6461  
30-4845 30-6463

DIVISION ALBANY  
REV 01-28-97

↑ TO MARTINSVILLE  
SEE ZONE 4  
PAGE 2

TO NIAGARA  
FALLS  
SEE ZONE 5  
PAGE 16

TO BUFFALO  
SEE ZONE 4  
PAGE 3

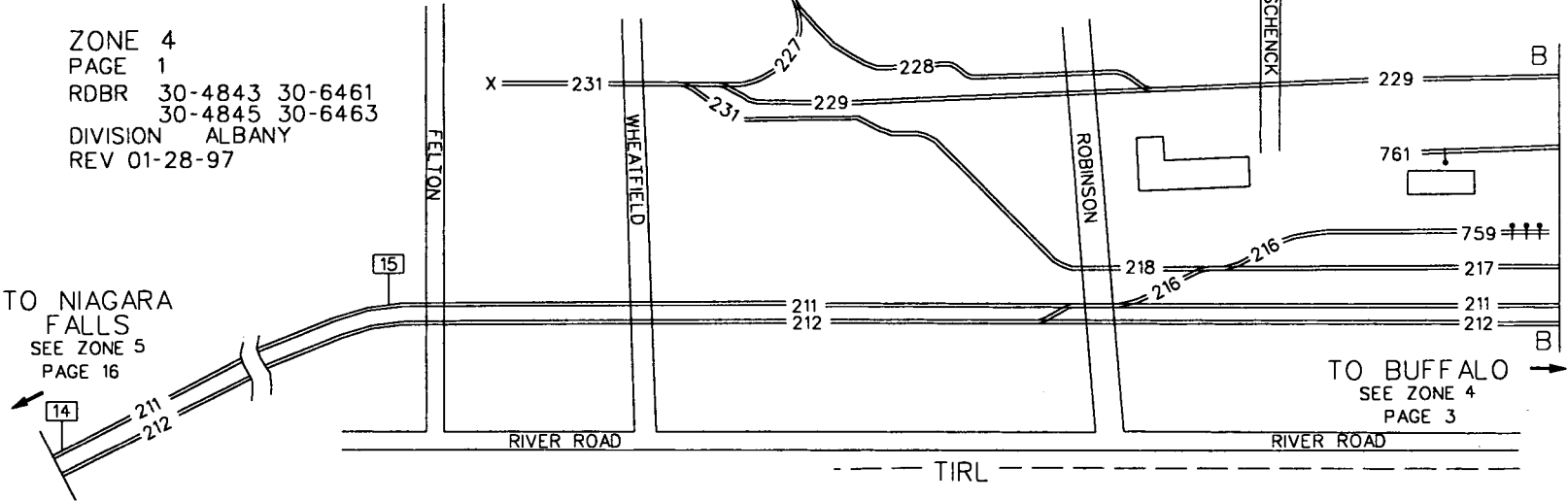

X 231

N MARION

FELTON

WHEATFIELD

ROBINSON

SCHENCK

RIVER ROAD

RIVER ROAD

TIRL

B

B

4 214 00 00 Lockport - Running - Tk.  
4 219 00 00 Wurlitzer Ind.  
4 731 01 08 Occidental Chemical - Shipper Tk.  
4 732 01 04 Occidental Chemical - Cleanout Tk.  
4 733 01 01 Occidental Chemical - 41 Tk.  
4 734 01 06 Occidental Chemical - Warehouse Tk.  
4 735 99 99 Occidental Chemical - Industrial Lead  
4 736 01 01 Occidental Chemical - Spur 4 Tk.  
4 737 01 02 Occidental Chemical - Spur 3 Tk.  
4 738 01 02 Occidental Chemical - Spur 2 Tk.  
4 739 01 02 Occidental Chemical - Spur 1 Tk.  
4 740 01 01 Occidental Chemical - 81 Tk.  
4 744 01 05 Battenfeld Grease & Oil  
4 745 99 99 Young Trucking  
4 745 99 99 Mye Lumber  
4 748 01 02 Thiele Coal & Feed  
4 750 99 99 Stone Container

MARTINSVILLE  
NY

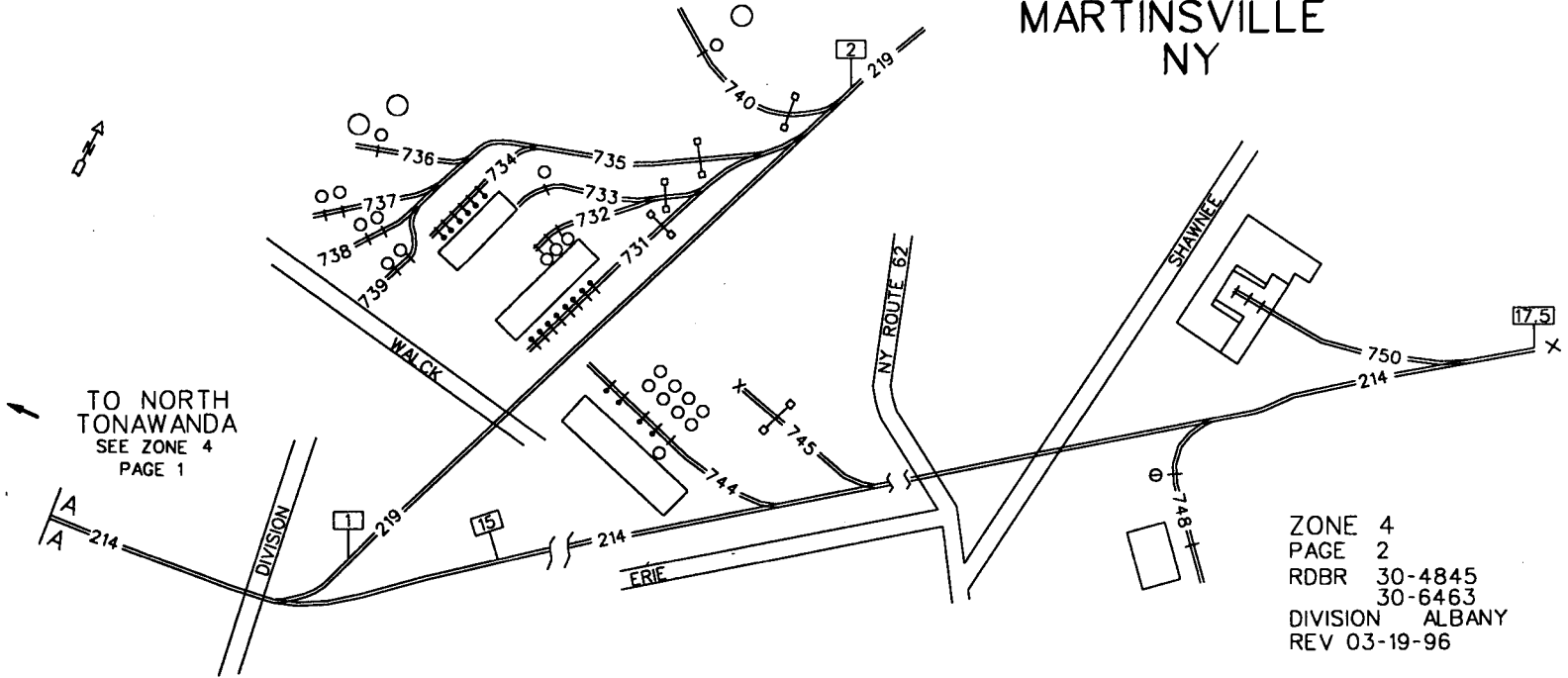

TO NORTH  
TONAWANDA  
SEE ZONE 4  
PAGE 1

ZONE 4  
PAGE 2  
RDBR 30-4845  
30-6463  
DIVISION ALBANY  
REV 03-19-96

ZONE 4

Rev 12/23/96

PAGE 3

4 211 00 00 Niagara - Branch - Tk.#1  
4 212 00 00 Niagara - Branch - Tk.#2  
4 217 00 00 Ind. Lead - Tk.  
4 229 00 00 Erie Industrial  
4 237 00 00 Tonawanda - Ind.  
4 240 00 00 Lead  
4 245 00 00 Ind. Lead - Tk.  
4 630 00 00 (TIRL) - I/C - Tk.  
4 761 01 01 Tondisco  
4 763 01 01 Frontier Fibre  
4 764 99 99 Frontier Fibre  
4 766 99 99 Exolon ESK  
4 767 01 11 Exolon ESK  
4 788 01 02 84 Lumber  
4 790 01 05 Martin Fireproofing

# NORTH TONAWANDA NY

# TONAWANDA NY

ZONE 4  
PAGE 3  
RDBR 30-4843 30-4844  
30-6461 30-4845  
DIVISION ALBANY  
REV 01-28-97



TO NIAGARA  
FALLS  
SEE ZONE 4  
PAGE 1

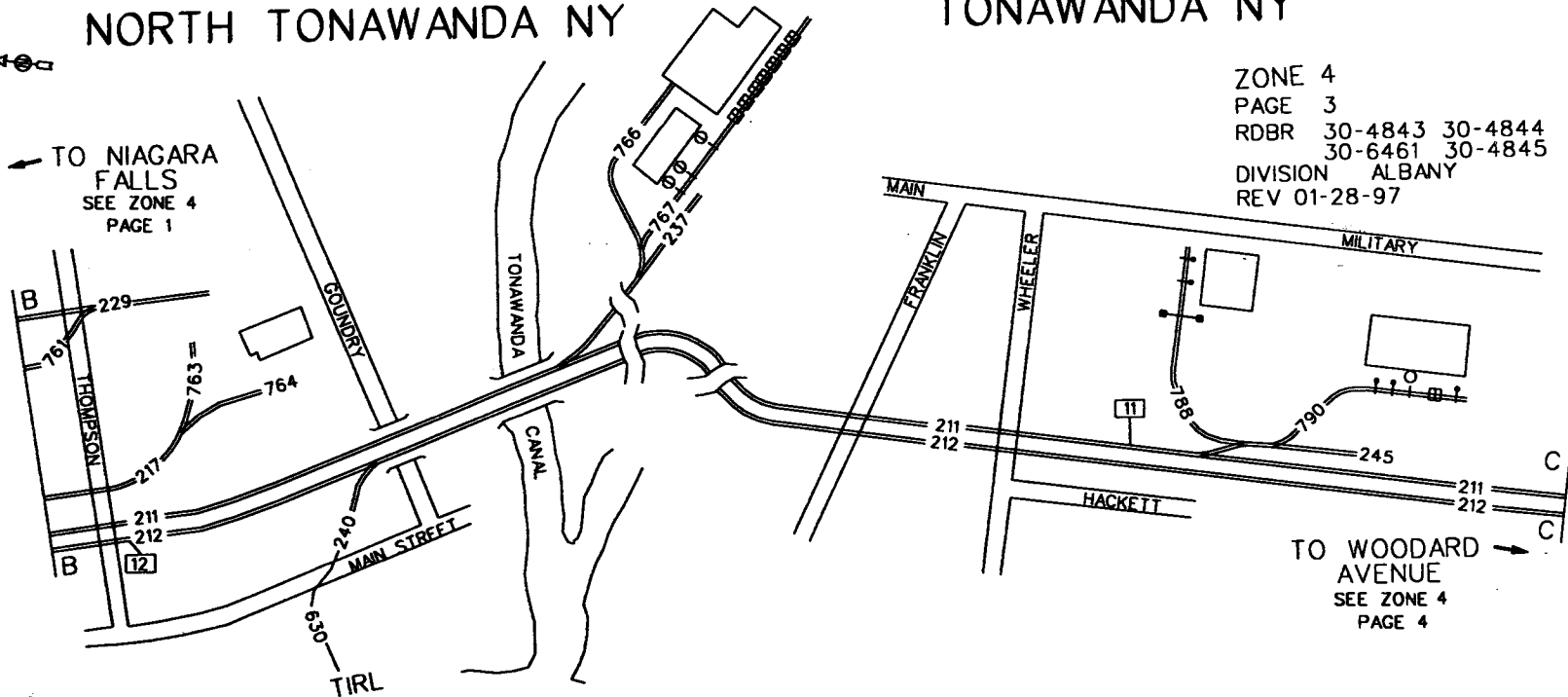

TO WOODARD  
AVENUE  
SEE ZONE 4  
PAGE 4

ZONE 4

Rev 2/13/97

PAGE 4

4 211 00 00 Niagara - Branch - Tk.#1  
4 212 00 00 Niagara - Branch - Tk.#2  
4 247 00 00 Ind. Lead - Tk.  
4 796 99 99 Terminal of Commerce  
4 797 99 99 Terminal of Commerce  
4 798 99 99 General Electric  
4 799 99 99 General Electric  
4 801 99 99 Terminal of Commerce - Tk.#1  
4 804 99 99 Terminal of Commerce - Tk.#4  
4 805 99 99 Terminal of Commerce - Tk.#5  
4 807 01 01 Lucidol  
4 810 01 01 Praxair  
4 811 99 99 Praxair  
4 812 99 99 Praxair  
4 813 99 99 Praxair  
4 814 99 99 Praxair  
4 815 99 99 Praxair  
4 816 99 99 Praxair  
4 817 99 99 Praxair  
4 818 99 99 Praxair

# TONAWANDA NY

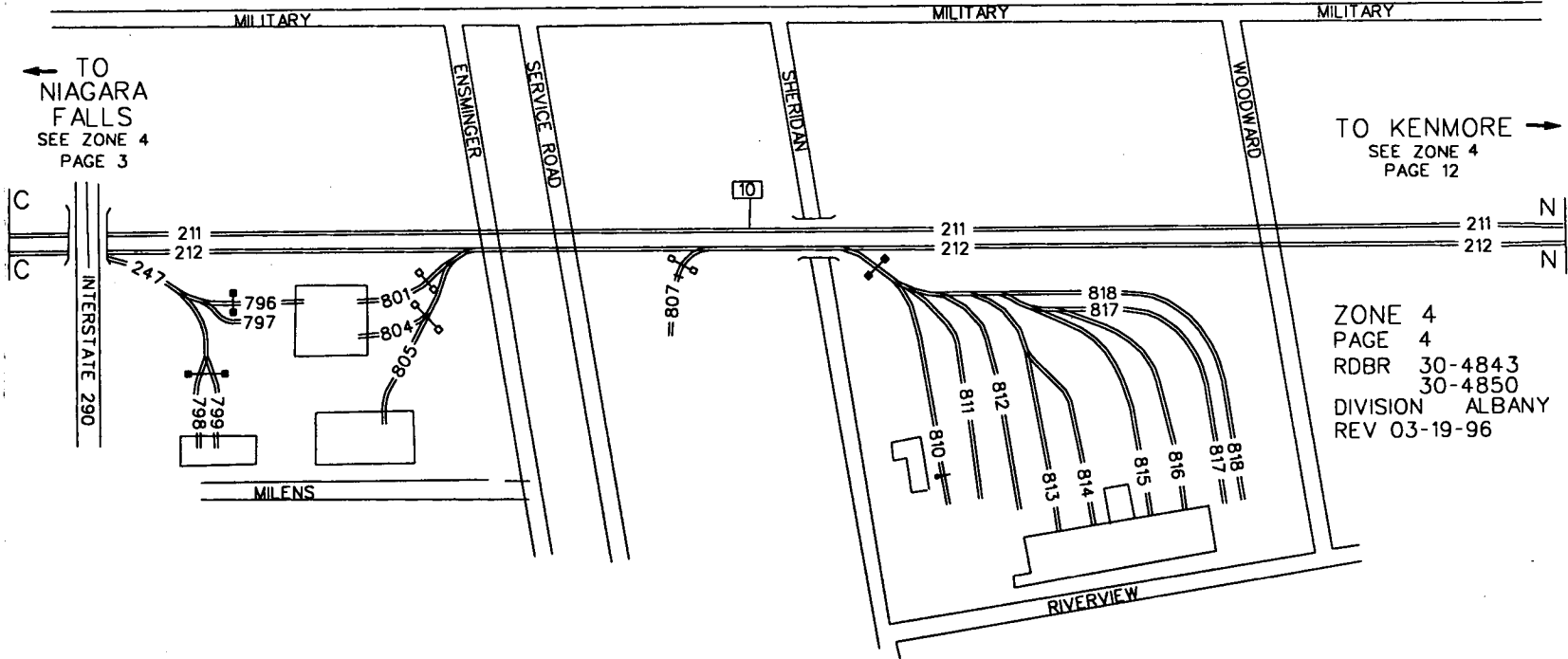

← TO  
NIAGARA  
FALLS  
SEE ZONE 4  
PAGE 3

TO KENMORE →  
SEE ZONE 4  
PAGE 12

ZONE 4  
PAGE 4  
RDBR 30-4843  
30-4850  
DIVISION ALBANY  
REV 03-19-96

4 249 00 00 North - Wye Tk.  
4 250 00 00 Kenmore - Yd. Lead  
4 251 00 00 Wonalancet - Running  
4 253 00 00 South - Side - Lead Tk.  
4 257 00 00 Lead  
4 540 00 00 Diesel - Tk.  
4 541 00 00 M of W  
4 601 00 00 Kenmore - Yd. Tk.#1  
4 602 00 00 Kenmore - Yd. Tk.#2  
4 603 00 00 Kenmore - Yd. Tk.#3  
4 604 00 00 Kenmore - Yd. Tk.#4  
4 605 00 00 Kenmore - Yd. Tk.#5  
4 606 00 00 Kenmore - Yd. Tk.#6  
4 607 00 00 Kenmore - Yd. Tk.#7  
4 608 00 00 Kenmore - Yd. Tk.#8  
4 609 00 00 Kenmore - Yd. Tk.#9  
4 610 00 00 Kenmore - Yd. Tk.#10  
4 611 00 00 Kenmore - Yd. Tk.#11  
4 612 00 00 Kenmore - Yd. Tk.#12  
4 613 00 00 Kenmore - Yd. Tk.#13  
4 614 00 00 Kenmore - Yd. Tk.#14  
4 615 00 00 Kenmore - Yd. Tk.#15  
4 616 00 00 Kenmore - Yd. Tk.#16  
4 617 00 00 Kenmore - Yd. Tk.#17  
4 618 00 00 Kenmore - Yd. Tk.#18  
4 619 00 00 Kenmore - Yd. Tk.#19  
4 620 00 00 Kenmore - Yd. Tk.#20  
4 626 00 00 Kenmore - Yd. Tk.#26  
4 626 97 97 Exxon USA  
4 628 00 00 Kenmore - Yd. Tk.#28  
4 678 00 00 Kenmore - Yd. Tk.(A)  
4 679 00 00 Kenmore - Yd. Tk.(B)  
4 680 00 00 Kenmore - Yd. Tk.(C)  
4 820 99 99 Frontier Warehousing  
4 823 97 97 Erie Fence Co  
4 823 97 97 Niagara Warehouse  
4 823 97 97 Kenmore - (Team Tk.)  
4 823 97 97 Indeck Power Equipment  
4 823 97 97 Frontier Lumber Co  
4 823 97 97 Appliance Associates  
4 823 97 97 E and R Trucking  
4 848 99 99 GM PT Tonawanda Engine River - Tk.#23  
4 849 99 99 GM PT Tonawanda Engine River - Tk.#24  
4 850 99 99 GM PT Tonawanda - North Side Lead #1  
4 854 99 99 E.I. Dupont - Woods Tk.



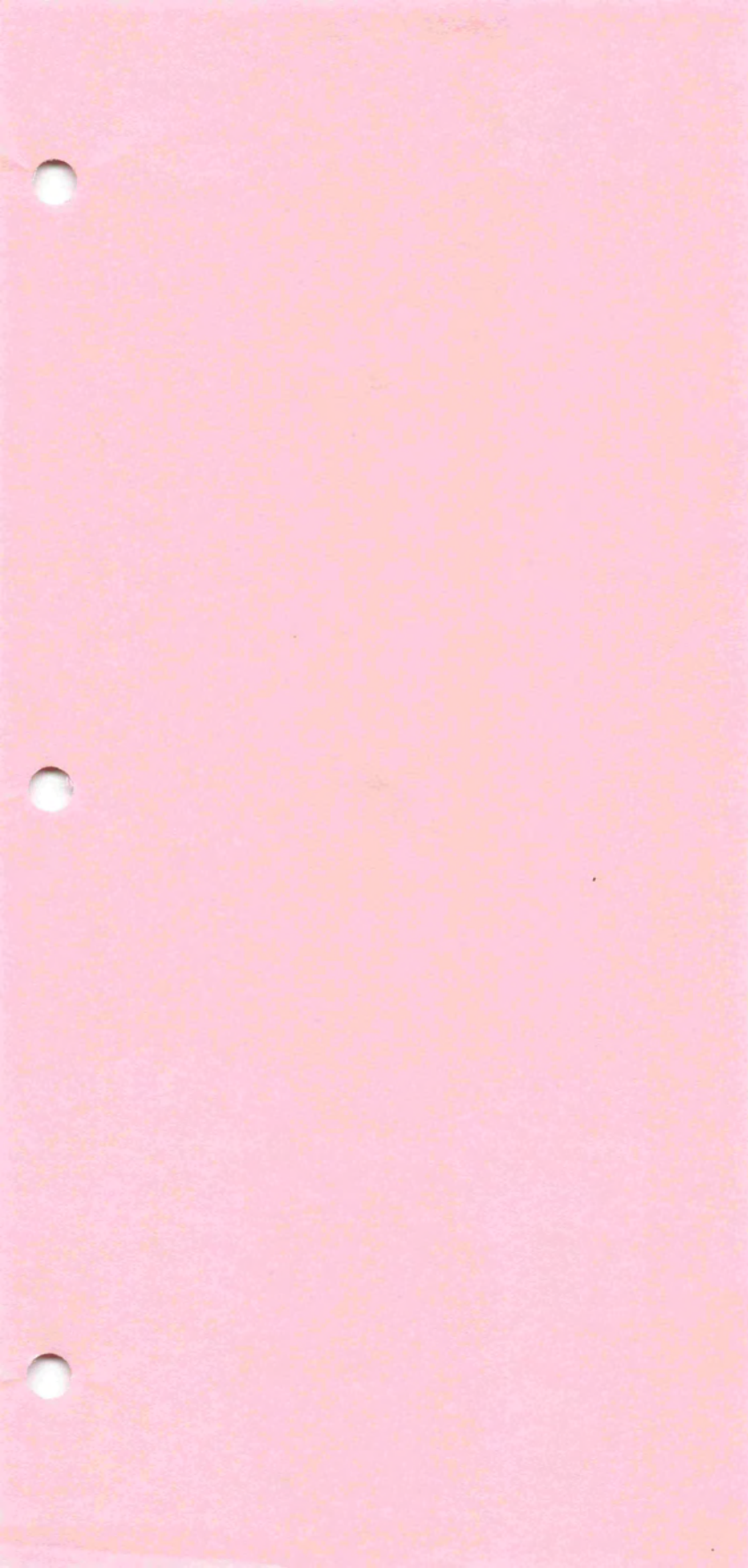

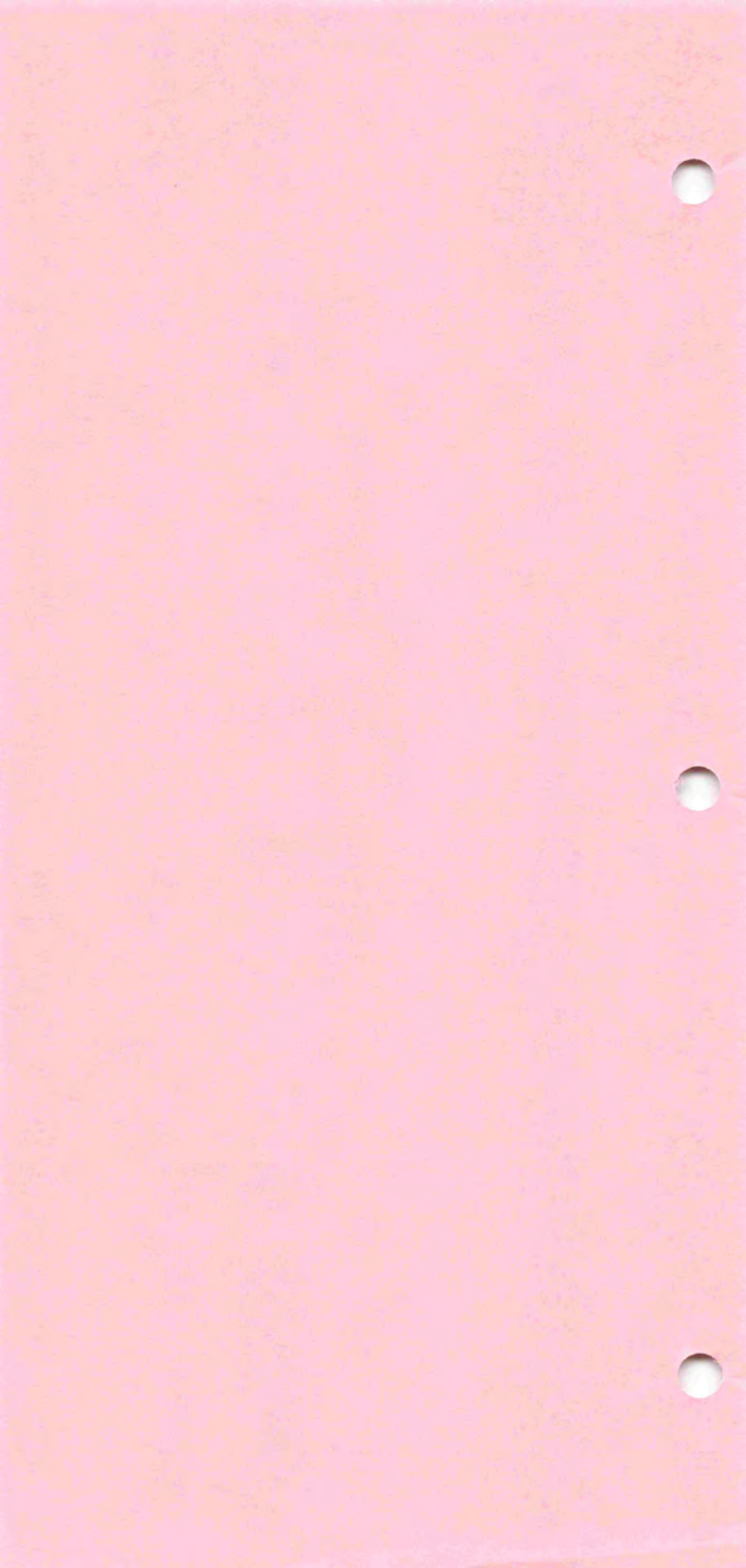

ZONE 4

Rev 12/11/96

PAGE 6

|   |     |    |    |   |
|---|-----|----|----|---|
| 4 | 253 | 00 | 00 | South - Side - Lead Tk.                 |
| 4 | 833 | 99 | 99 | GM PT Tonawanda Engine River - Tk.#4 A  |
| 4 | 834 | 01 | 03 | GM PT Tonawanda Engine River - Tk.#4    |
| 4 | 837 | 99 | 99 | GM PT Tonawanda Engine River - Tk.#17   |
| 4 | 842 | 99 | 99 | GM PT Tonawanda Engine River - Lead Tk. |
| 4 | 843 | 99 | 99 | GM PT Tonawanda Engine - Tk.#6 A Lead   |
| 4 | 848 | 99 | 99 | GM PT Tonawanda Engine River - Tk.#23   |
| 4 | 849 | 99 | 99 | GM PT Tonawanda Engine River - Tk.#24   |
| 4 | 850 | 99 | 99 | GM PT Tonawanda - North Side Lead #1    |

# TONAWANDA NY

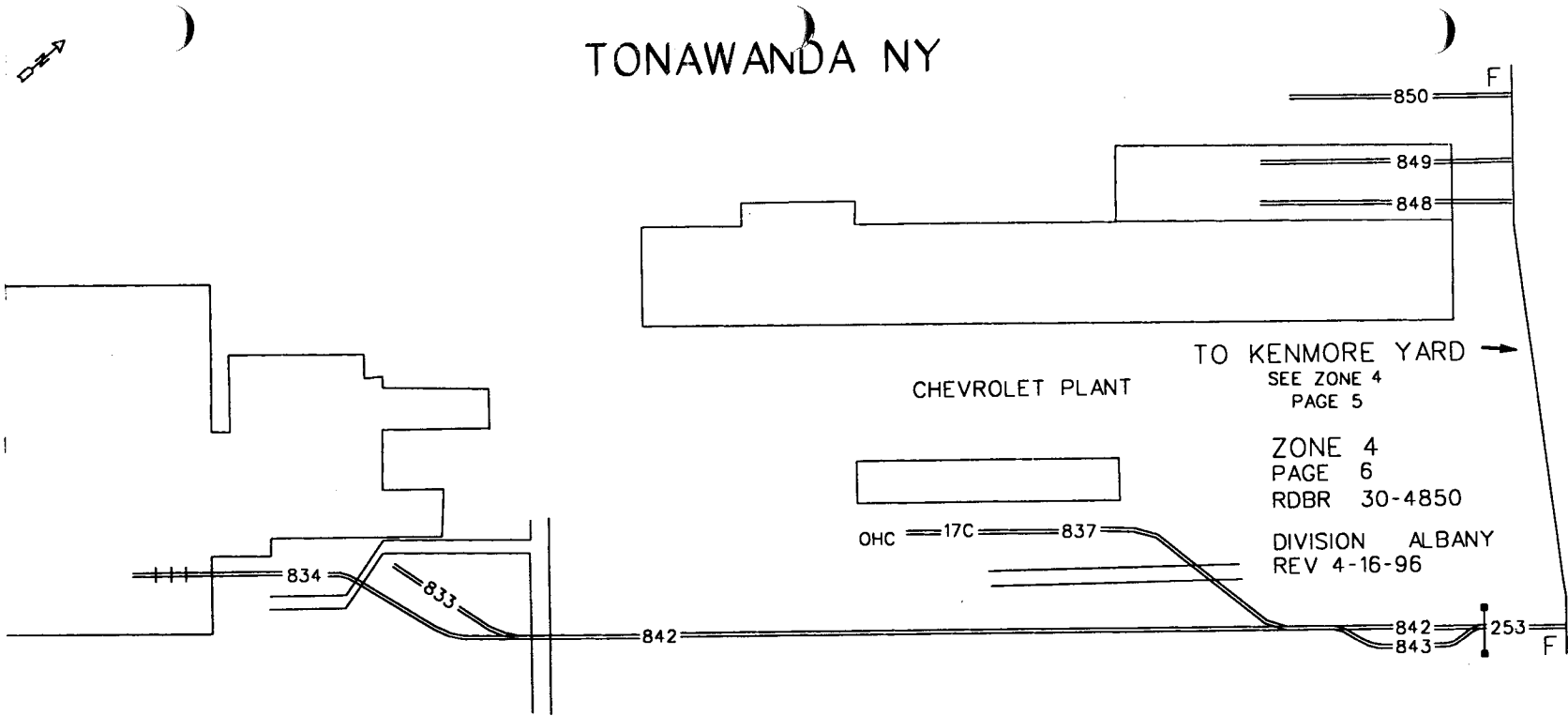

TO KENMORE YARD →

CHEVROLET PLANT

SEE ZONE 4  
PAGE 5

ZONE 4  
PAGE 6  
RDBR 30-4850

DIVISION ALBANY  
REV 4-16-96

F

F

ZONE 4

Rev 12/11/96

PAGE 7

4 854 99 99 E.I. Dupont - Woods Tk.



# TONAWANDA NY

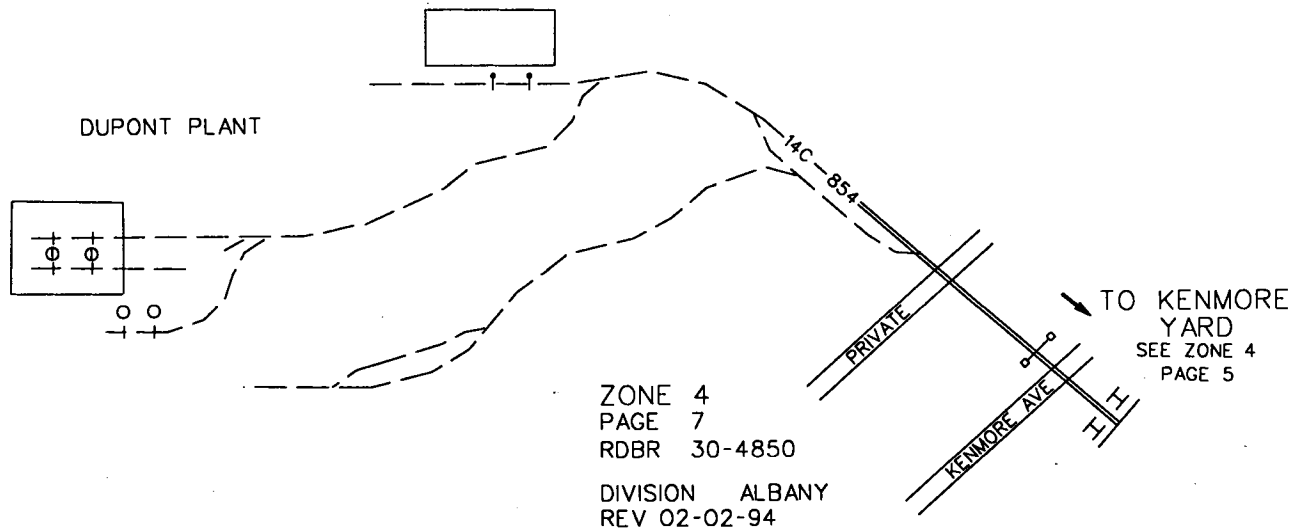

ZONE 4

Rev 12/11/96

PAGE 8

|   |     |    |    |                             |
|---|-----|----|----|-----------------------------|
| 4 | 251 | 00 | 00 | Wonalancet - Running        |
| 4 | 263 | 00 | 00 | Huntley - Yd. Lead          |
| 4 | 269 | 00 | 00 | Batavia - Switch            |
| 4 | 271 | 00 | 00 | Ind. Lead - Tk.             |
| 4 | 272 | 00 | 00 | Wye Tk.                     |
| 4 | 876 | 01 | 04 | Chem Central                |
| 4 | 877 | 99 | 99 | Chem Central Lead           |
| 4 | 878 | 01 | 03 | Noco Lubricants             |
| 4 | 878 | 01 | 03 | Chem Central                |
| 4 | 880 | 01 | 02 | Ashland Chemical - Tk.      |
| 4 | 881 | 99 | 99 | Ashland Chemical - Tk. Lead |
| 4 | 882 | 01 | 02 | Ashland Chemical - Tk.      |
| 4 | 884 | 99 | 99 | Tonawanda Coke              |

# TONAWANDA NY (HARRIET)

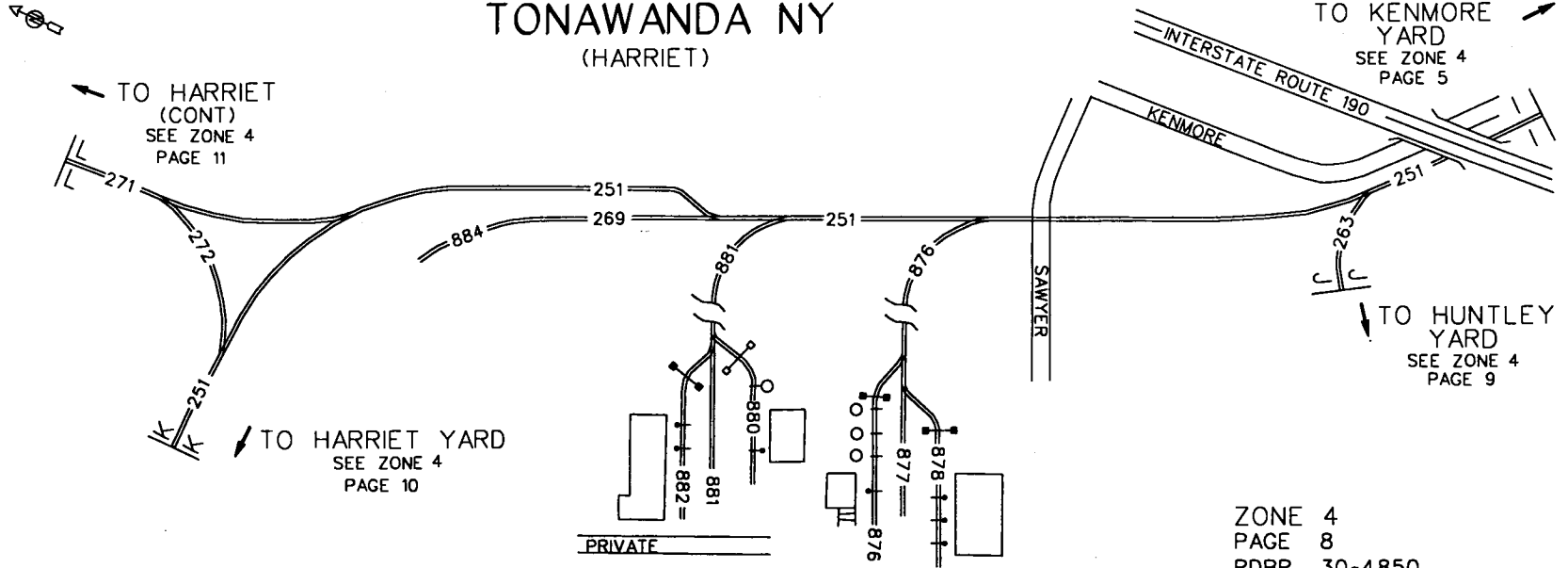

ZONE 4  
PAGE 8  
RDBR 30-4850

DIVISION ALBANY  
REV 04-16-96



|   |     |    |    |                                    |
|---|-----|----|----|------------------------------------|
| 4 | 263 | 00 | 00 | Huntley - Yd. Lead                 |
| 4 | 265 | 00 | 00 | Dunlop Tire & Rubber - Lead        |
| 4 | 267 | 00 | 00 | Ind. Lead - Tk.                    |
| 4 | 660 | 00 | 00 | BG&E Main Tk.                      |
| 4 | 661 | 00 | 00 | BG&E Tk.#1                         |
| 4 | 662 | 00 | 00 | BG&E Tk.#2                         |
| 4 | 663 | 00 | 00 | BG&E Tk.#3                         |
| 4 | 664 | 00 | 00 | BG&E Tk.#4                         |
| 4 | 856 | 01 | 02 | Ocello                             |
| 4 | 858 | 01 | 01 | Dunlop Tire & Rubber - Tk.         |
| 4 | 859 | 99 | 99 | Dunlop Tire & Rubber - PU/SO Tk.   |
| 4 | 860 | 99 | 99 | Dunlop Tire & Rubber - Runaround   |
| 4 | 861 | 99 | 99 | Dunlop Tire & Rubber - Tk.         |
| 4 | 862 | 99 | 99 | Dunlop Tire & Rubber - Scale - Tk. |
| 4 | 863 | 99 | 99 | Dunlop Tire & Rubber - Tk.         |
| 4 | 864 | 99 | 99 | Dunlop Tire & Rubber - Tk.         |
| 4 | 865 | 99 | 99 | Dunlop Tire & Rubber - Tk.         |
| 4 | 866 | 01 | 01 | Dunlop Tire & Rubber - Tk.         |
| 4 | 870 | 01 | 03 | Vacant                             |
| 4 | 871 | 99 | 99 | F M C - Tk.#1                      |
| 4 | 872 | 99 | 99 | F M C - Tk.#6                      |
| 4 | 873 | 99 | 99 | Niagara Mohawk Power - Tk.         |
| 4 | 874 | 99 | 99 | Niagara Mohawk Power - Tk.         |
| 4 | 875 | 99 | 99 | Niagara Mohawk Power - Tk.         |

# TONAWANDA NY

(HUNTLEY YARD)

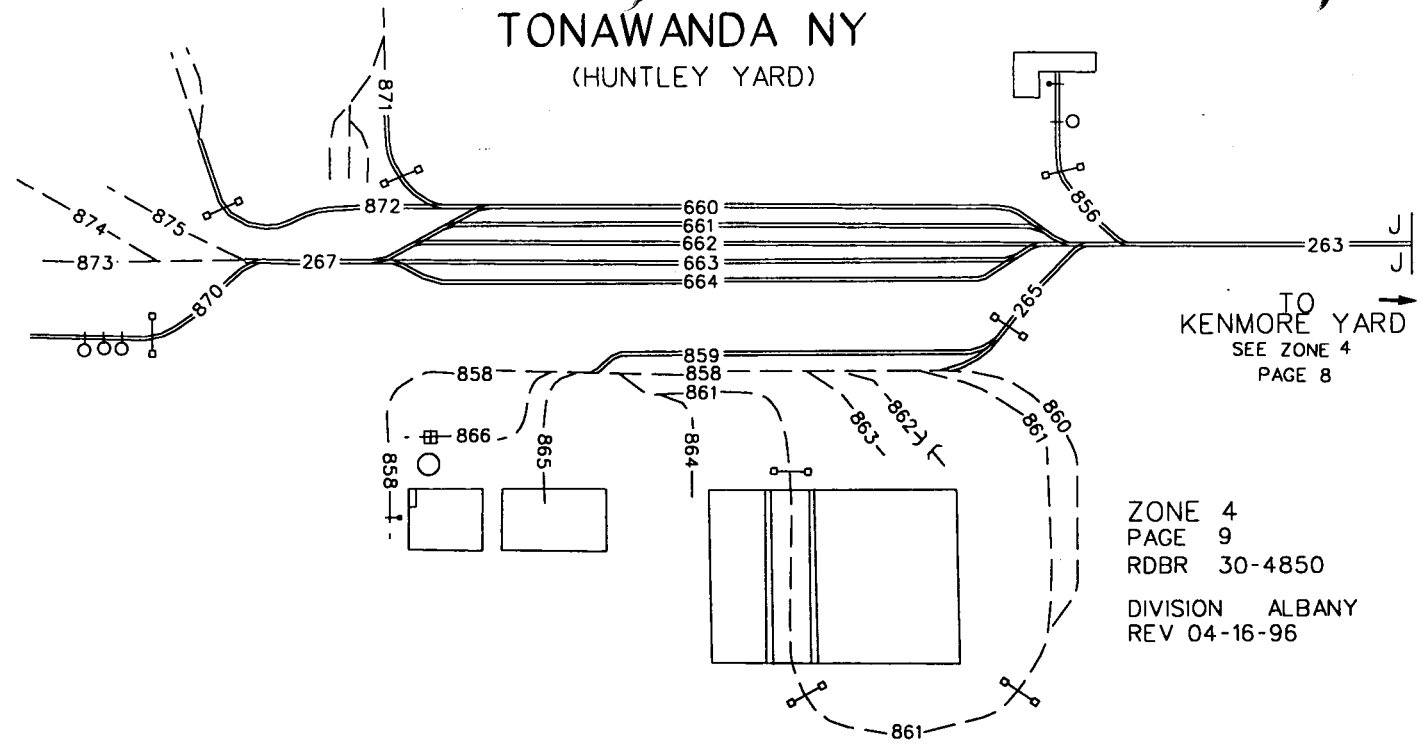

TO  
KENMORE YARD  
SEE ZONE 4  
PAGE 8

ZONE 4  
PAGE 9  
RDBR 30-4850  
DIVISION ALBANY  
REV 04-16-96

ZONE 4

Rev 12/11/96

PAGE 10

|   |     |    |    |                      |
|---|-----|----|----|----------------------|
| 4 | 251 | 00 | 00 | Wonalancet - Running |
| 4 | 274 | 00 | 00 | Ind. Lead - Tk.      |
| 4 | 683 | 00 | 00 | Harriet - Yd. Tk.#3  |
| 4 | 693 | 00 | 00 | Harriet - Yd. Tk.#13 |
| 4 | 885 | 99 | 99 | Tonawanda Coke       |
| 4 | 886 | 99 | 99 | Tonawanda Coke       |
| 4 | 887 | 01 | 01 | INS Equipment        |

A  
N  
D

# TONAWANDA NY

(HARRIET YARD)

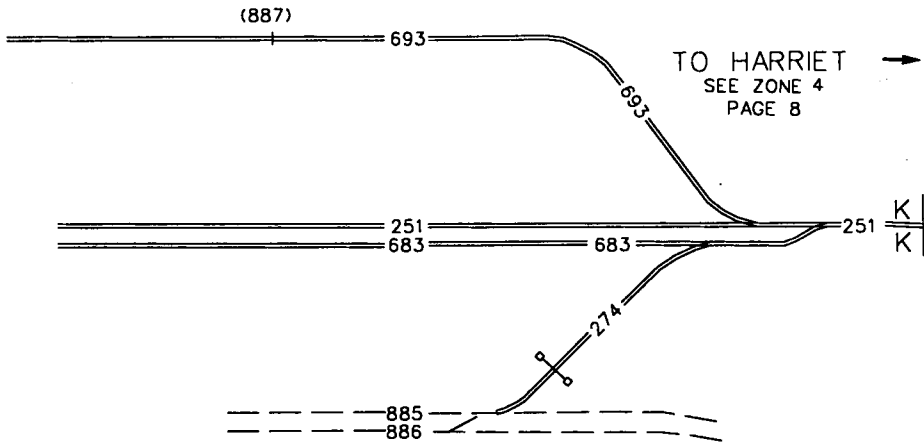

TO HARRIET  
SEE ZONE 4  
PAGE 8



K  
K

ZONE 4  
PAGE 10  
RDBR 30-4850

DIVISION ALBANY  
REV 04-16-96

ZONE 4

Rev 12/23/96

PAGE 11

4 271 00 00 Ind. Lead - Tk.  
4 889 01 04 Newman Oil  
4 894 01 10 United Refinery

TONAWANDA NY  
(HARRIET)

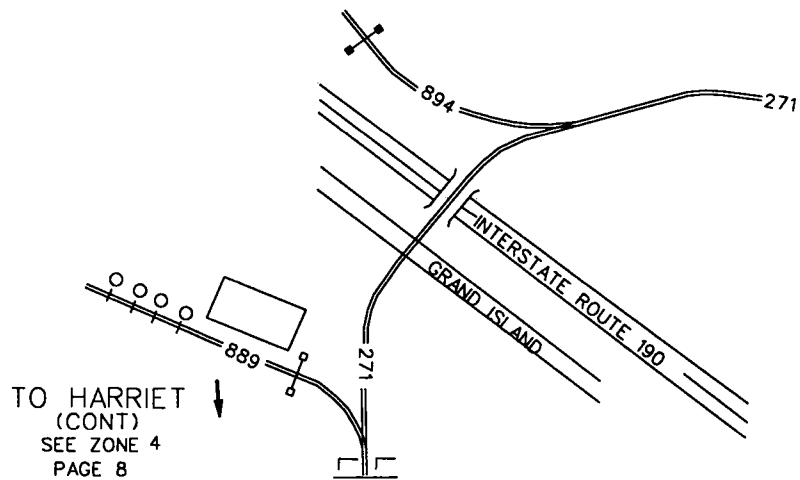

TO HARRIET  
(CONT)  
SEE ZONE 4  
PAGE 8

ZONE 4  
PAGE 11  
RDBR 30-4850

DIVISION ALBANY  
REV 04-16-96

ZONE 4

Rev 12/11/96

PAGE 12

|   |     |    |    |                            |
|---|-----|----|----|----------------------------|
| 4 | 211 | 00 | 00 | Niagara - Branch - Tk.#1   |
| 4 | 212 | 00 | 00 | Niagara - Branch - Tk.#2   |
| 4 | 249 | 00 | 00 | North Wye Tk.              |
| 4 | 251 | 00 | 00 | Wonalancet - Running       |
| 4 | 282 | 00 | 00 | Black Rock - Ind.          |
| 4 | 285 | 00 | 00 | Kam Siding                 |
| 4 | 291 | 00 | 00 | Belt Line - Branch - Tk.#1 |
| 4 | 292 | 00 | 00 | Belt Line - Branch - Tk.#2 |
| 4 | 293 | 00 | 00 | Wye Tk.                    |
| 4 | 908 | 99 | 99 | American Brass             |
| 4 | 911 | 01 | 03 | Tenneco Packaging Inc.     |

BUFFALO NY  
(KENMORE)

TO KENMORE  
(CONT)  
SEE ZONE 4  
PAGE 13

TO CP  
SYCAMORE  
STREET  
SEE ZONE 4  
PAGE 14

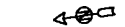

TO NIAGARA  
FALLS  
SEE ZONE 4  
PAGE 4

TO  
BLACK ROCK  
SEE ZONE 4  
PAGE 17

TO  
KENMORE YARD  
SEE ZONE 4  
PAGE 5

ZONE 4  
PAGE 12  
RDBR 30-4842 30-4843  
30-4850 30-6462  
DIVISION ALBANY  
REV 01-28-976

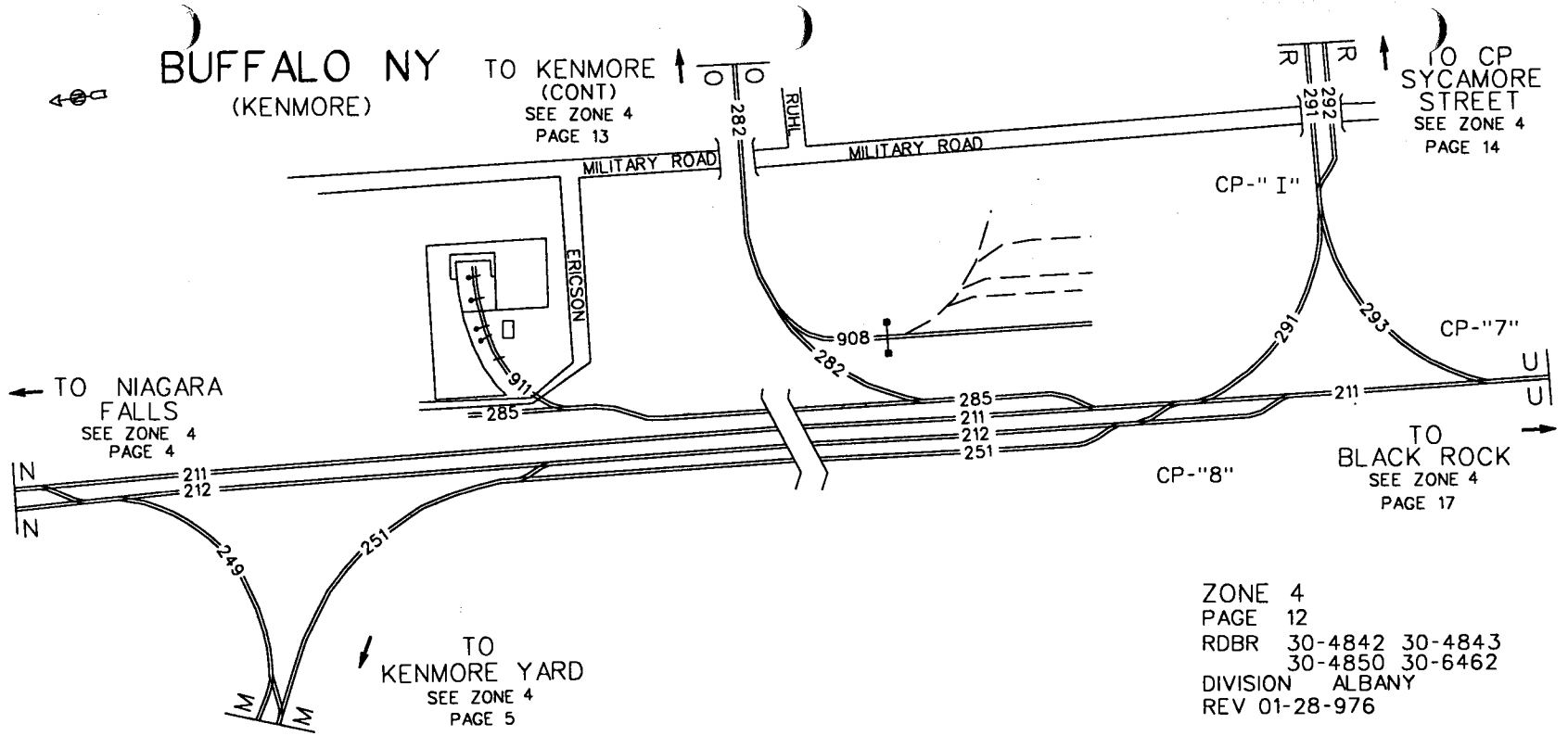



**ZONE 4**

**Rev 12/11/96**

**PAGE 13**

|   |     |    |    |                    |
|---|-----|----|----|--------------------|
| 4 | 282 | 00 | 00 | Black Rock - Ind.  |
| 4 | 898 | 99 | 99 | Buffalo Stg.       |
| 4 | 899 | 99 | 99 | Buffalo Stg.       |
| 4 | 901 | 01 | 01 | Protective Closure |



# BUFFALO NY

(KENMORE)

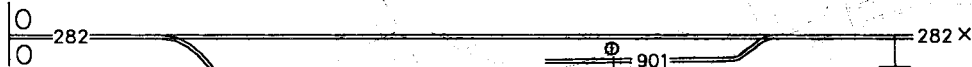

← TO KENMORE  
 (CONT)  
 SEE ZONE 4  
 PAGE 12

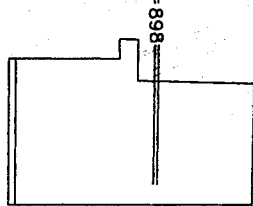

ELMWOOD

ZONE 4  
 PAGE 14  
 RDBR 30-4642  
 DIVISION ALBANY  
 REV 04-15-95

ZONE 4  
 PAGE 13  
 RDBR 30-6462  
 DIVISION ALBANY  
 REV 04-16-96

CIP SYCAMORE  
 STREET





# BUFFALO NY

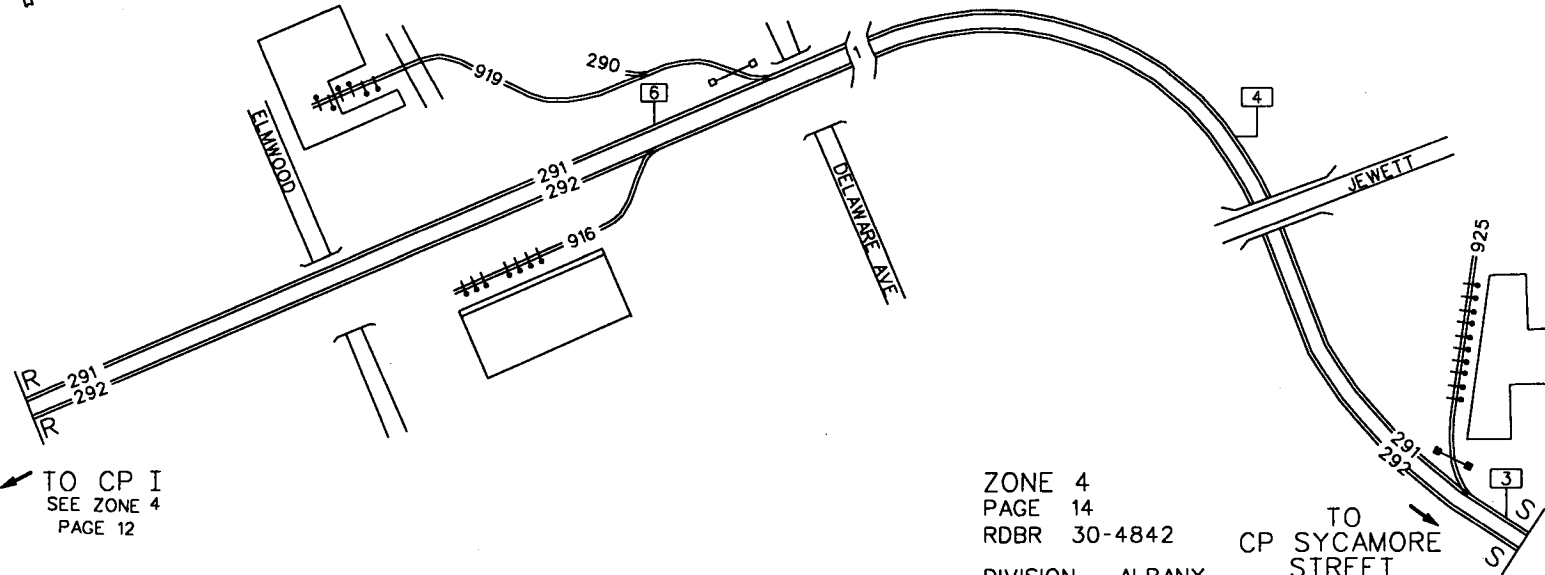

↖ TO CP I  
 SEE ZONE 4  
 PAGE 12

ZONE 4  
 PAGE 14  
 RDBR 30-4842

DIVISION ALBANY  
 REV 04-16-96

↗ TO CP SYCAMORE  
 STREET  
 SEE ZONE 4  
 PAGE 15

# BUFFALO NY

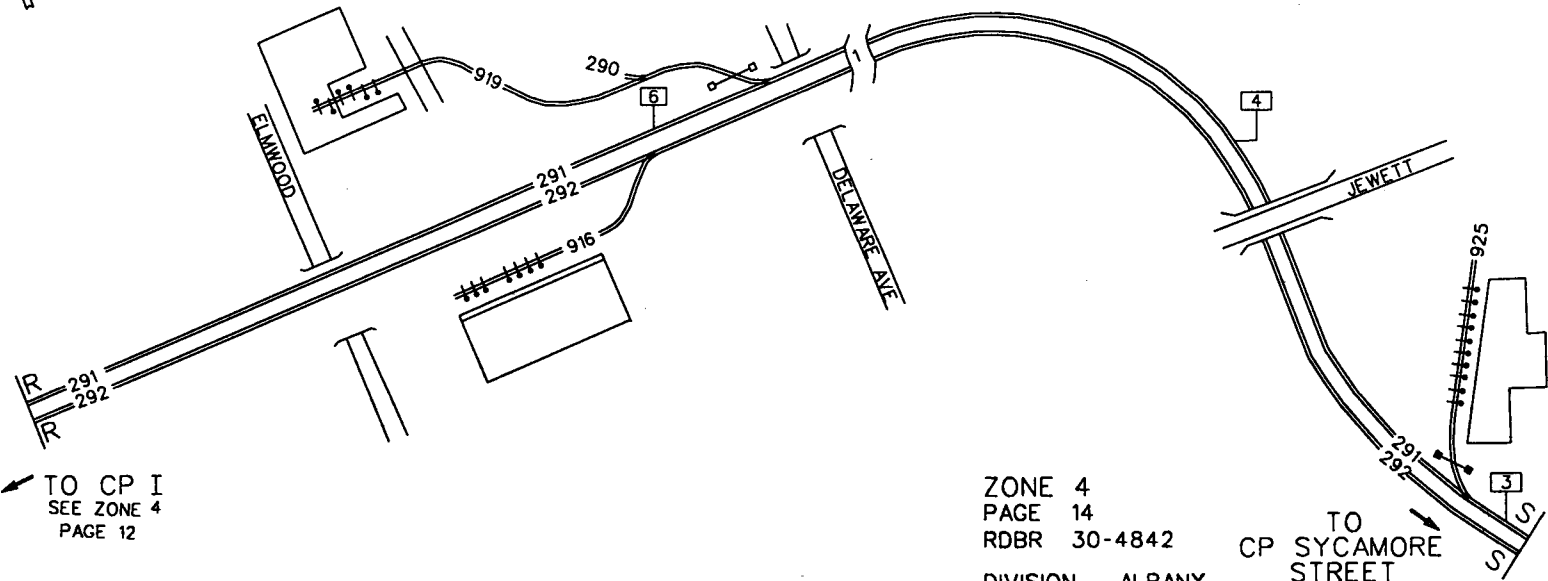

← TO CP I  
SEE ZONE 4  
PAGE 12

ZONE 4  
PAGE 14  
RDBR 30-4842  
DIVISION ALBANY  
REV 04-16-96

TO  
CP SYCAMORE  
STREET  
SEE ZONE 4  
PAGE 15

ZONE 4

Rev 12/23/96

PAGE 15

|   |     |    |    |                            |
|---|-----|----|----|----------------------------|
| 4 | 291 | 00 | 00 | Belt Line - Branch - Tk.#1 |
| 4 | 292 | 00 | 00 | Belt Line - Branch - Tk.#2 |
| 4 | 298 | 00 | 00 | South Siding               |
| 4 | 299 | 00 | 00 | North Siding               |
| 4 | 928 | 99 | 99 | Niagara Machine Tool - Tk. |
| 4 | 929 | 99 | 99 | Niagara Machine Tool - Tk. |
| 4 | 930 | 99 | 99 | Niagara Machine Tool - Tk. |
| 4 | 931 | 99 | 99 | Niagara Machine Tool - Tk. |
| 4 | 932 | 99 | 99 | Niagara Machine Tool - Tk. |
| 4 | 934 | 99 | 99 | Innovative Chemical        |
| 4 | 937 | 99 | 99 | Vacant                     |

# BUFFALO NY

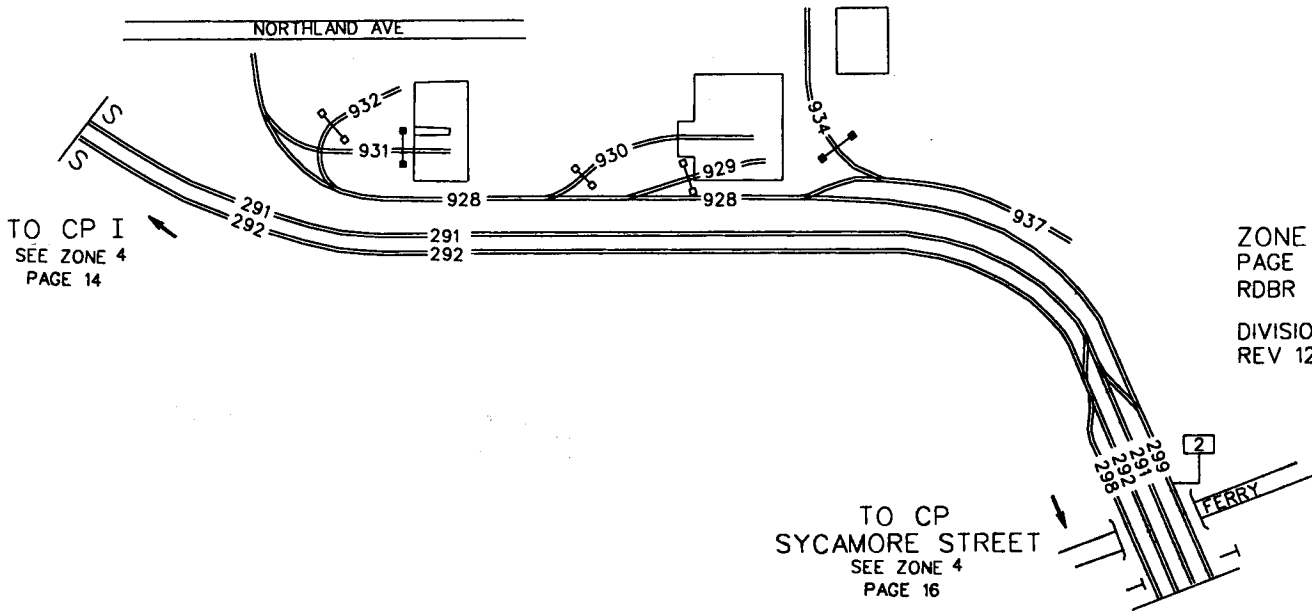

TO CP I  
SEE ZONE 4  
PAGE 14

ZONE 4  
PAGE 15  
RDBR 30-4842  
DIVISION ALBANY  
REV 12-01-89

TO CP  
SYCAMORE STREET  
SEE ZONE 4  
PAGE 16

ZONE 4

Rev 12/11/96

PAGE 16

|   |     |    |    |                            |
|---|-----|----|----|----------------------------|
| 4 | 291 | 00 | 00 | Belt Line - Branch - Tk.#1 |
| 4 | 292 | 00 | 00 | Belt Line - Branch - Tk.#2 |
| 4 | 298 | 00 | 00 | South Siding               |
| 4 | 299 | 00 | 00 | North Siding               |
| 4 | 948 | 99 | 99 | Interstate Brands Corp.    |
| 4 | 949 | 99 | 99 | Interstate Brands Corp.    |
| 4 | 951 | 01 | 03 | Nabisco Brands             |
| 4 | 952 | 99 | 99 | Nabisco Brands             |

BUFFALO NY

← TO CP I  
SEE ZONE 4  
PAGE 15

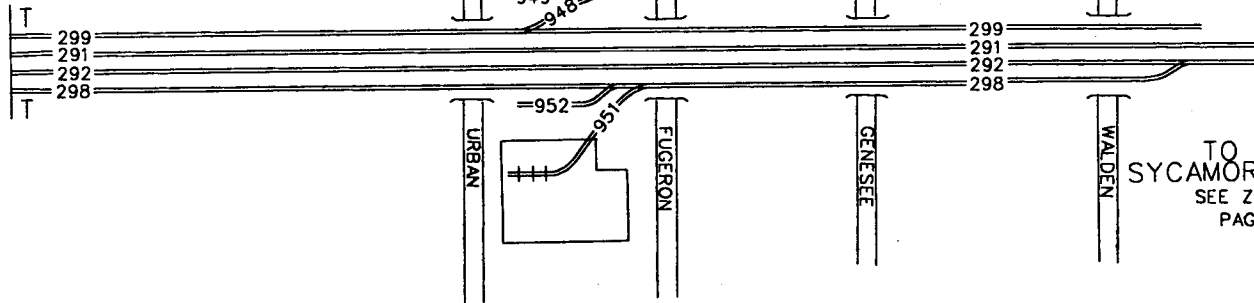

TO CP  
SYCAMORE STREET  
SEE ZONE 1  
PAGE 7 →

ZONE 4  
PAGE 16  
RDBR 30-4842

DIVISION ALBANY  
REV 04-16-96



ZONE 4

Rev 12/11/96

PAGE 17

|   |     |    |    |                          |
|---|-----|----|----|--------------------------|
| 4 | 211 | 00 | 00 | Niagara - Branch - Tk.#1 |
| 4 | 256 | 00 | 00 | Ind. Lead - Tk.          |
| 4 | 283 | 00 | 00 | Lead                     |
| 4 | 651 | 00 | 00 | (CN) - Connection - Tk.  |
| 4 | 957 | 97 | 97 | (Team Tk.)               |
| 4 | 960 | 01 | 14 | Pratt & Lambert          |
| 4 | 962 | 01 | 01 | Plywood Plastics         |
| 4 | 965 | 99 | 99 | Vacant                   |

# BUFFALO NY (BLACK ROCK)

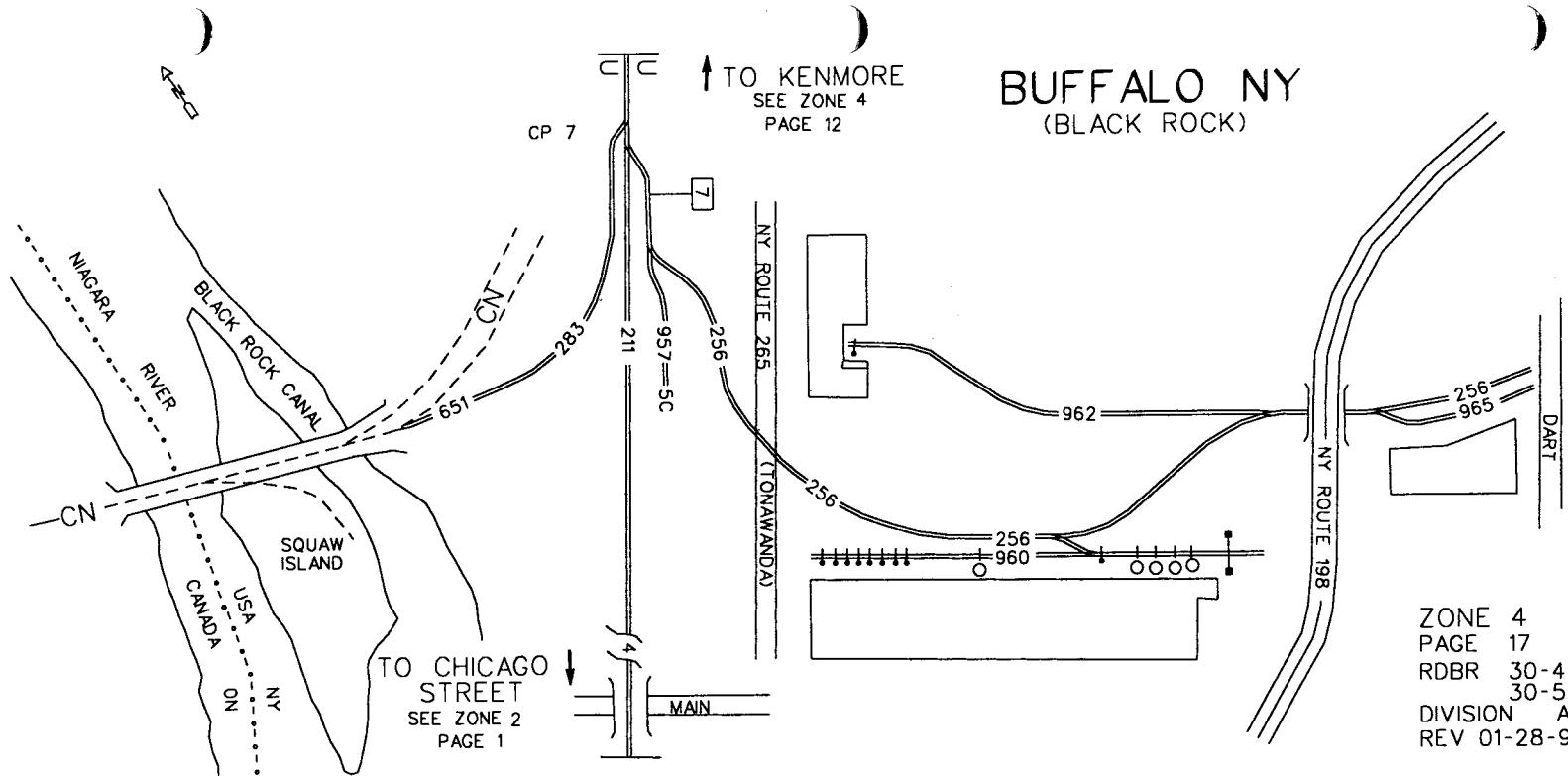

↑ TO KENMORE  
SEE ZONE 4  
PAGE 12

↓ TO CHICAGO STREET  
SEE ZONE 2  
PAGE 1

ZONE 4  
PAGE 17  
RDBR 30-4843  
30-5131  
DIVISION ALBANY  
REV 01-28-97



# NIAGARA FALLS - ZONE 5

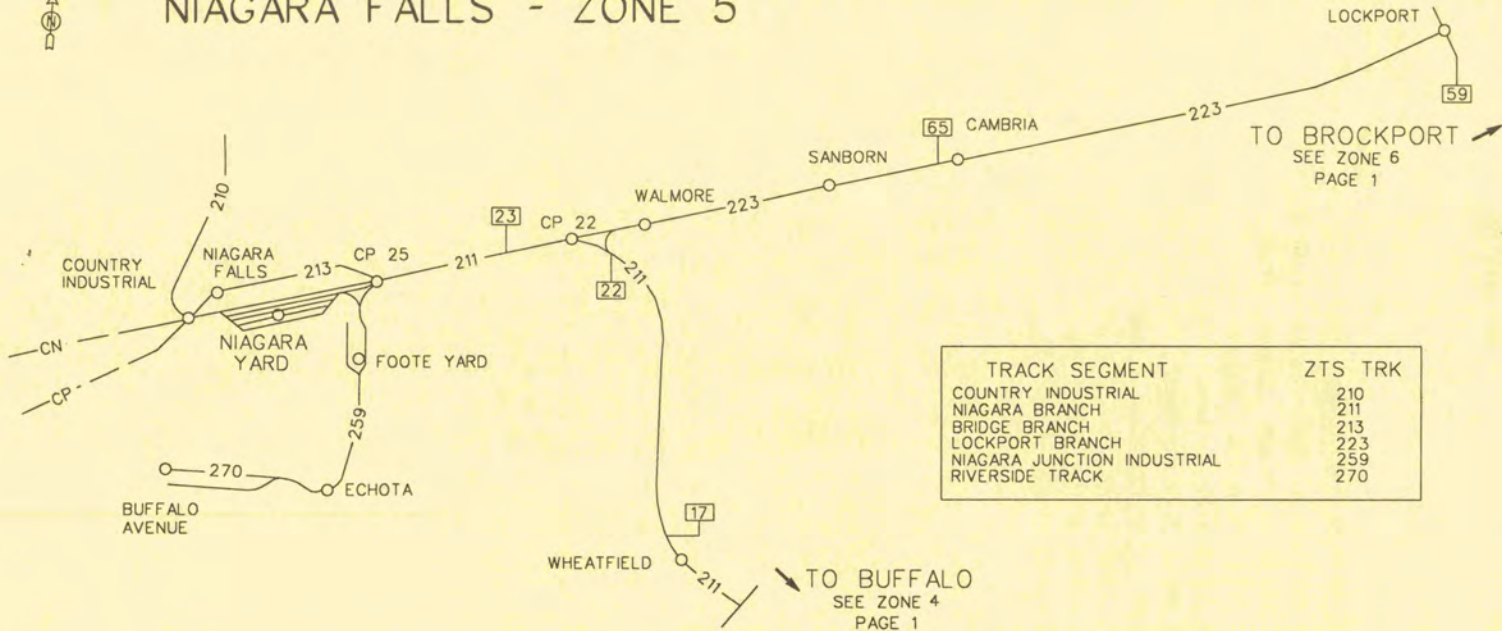

| TRACK SEGMENT               | ZTS TRK |
|-----------------------------|---------|
| COUNTRY INDUSTRIAL          | 210     |
| NIAGARA BRANCH              | 211     |
| BRIDGE BRANCH               | 213     |
| LOCKPORT BRANCH             | 223     |
| NIAGARA JUNCTION INDUSTRIAL | 259     |
| RIVERSIDE TRACK             | 270     |

TO BROCKPORT  
SEE ZONE 6  
PAGE 1

TO BUFFALO  
SEE ZONE 4  
PAGE 1

ZONE 05

Rev 04/01/94

PAGE 1

05 210 00 00 Country Ind.  
05 211 00 00 Niagara - Branch - Tk.#1  
05 212 00 00 Niagara - Branch - Tk.#2  
05 213 00 00 Bridge - Branch  
05 214 00 00 Main - Lead  
05 216 00 00 Shop - Lead  
05 217 00 00 Eng. House - Lead  
05 219 00 00 Yd. Lead  
05 637 00 00 (CP) - I/C - Tk.  
05 638 00 00 (CN) - I/C - Tk.

# NIAGARA FALLS NY (COUNTRY INDUSTRIAL)

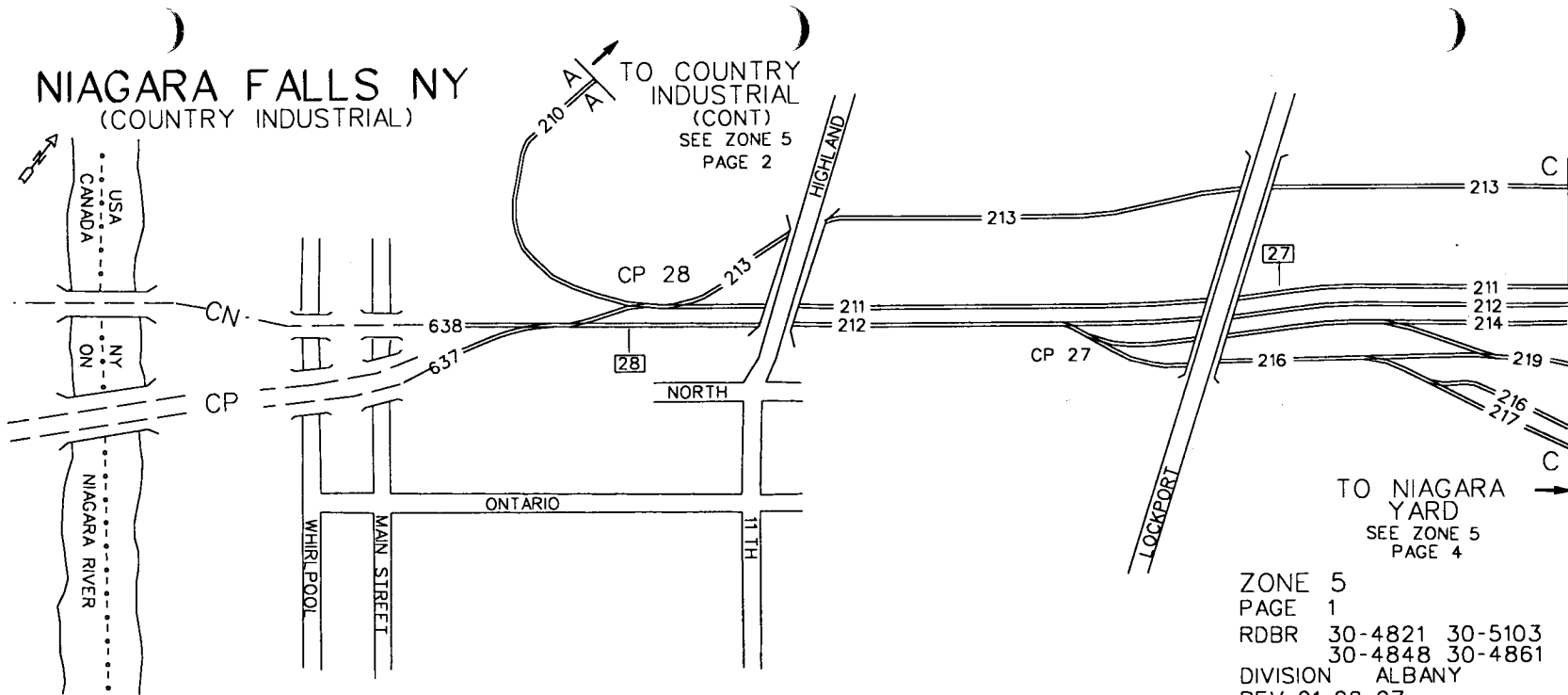

TO COUNTRY INDUSTRIAL (CONT)  
SEE ZONE 5  
PAGE 2

TO NIAGARA YARD  
SEE ZONE 5  
PAGE 4

ZONE 5  
PAGE 1  
RDBR 30-4821 30-5103  
30-4848 30-4861  
DIVISION ALBANY  
REV 01-28-97

ZONE 5

Rev 12/12/96

PAGE 2

|   |     |    |    |                          |
|---|-----|----|----|--------------------------|
| 5 | 210 | 00 | 00 | Country Ind.             |
| 5 | 218 | 00 | 00 | Ind. Lead - Tk.          |
| 5 | 221 | 00 | 00 | Ind. Lead - Tk.          |
| 5 | 227 | 00 | 00 | Industrial Lead          |
| 5 | 705 | 99 | 99 | United Metalurgical      |
| 5 | 706 | 01 | 10 | United Metalurgical      |
| 5 | 708 | 01 | 01 | Tulip Manufacturing      |
| 5 | 720 | 99 | 99 | Globe Metalurgical       |
| 5 | 722 | 01 | 01 | Treibacher Schleifmittel |
| 5 | 723 | 01 | 01 | Treibacher Schleifmittel |
| 5 | 726 | 99 | 99 | Forgione Lumber          |

# NIAGARA FALLS NY

(COUNTRY INDUSTRIAL)

TO  
COUNTRY  
INDUSTRIAL  
(CONT)  
SEE ZONE 5  
PAGE 3

TO CP 28  
SEE ZONE 5  
PAGE 1

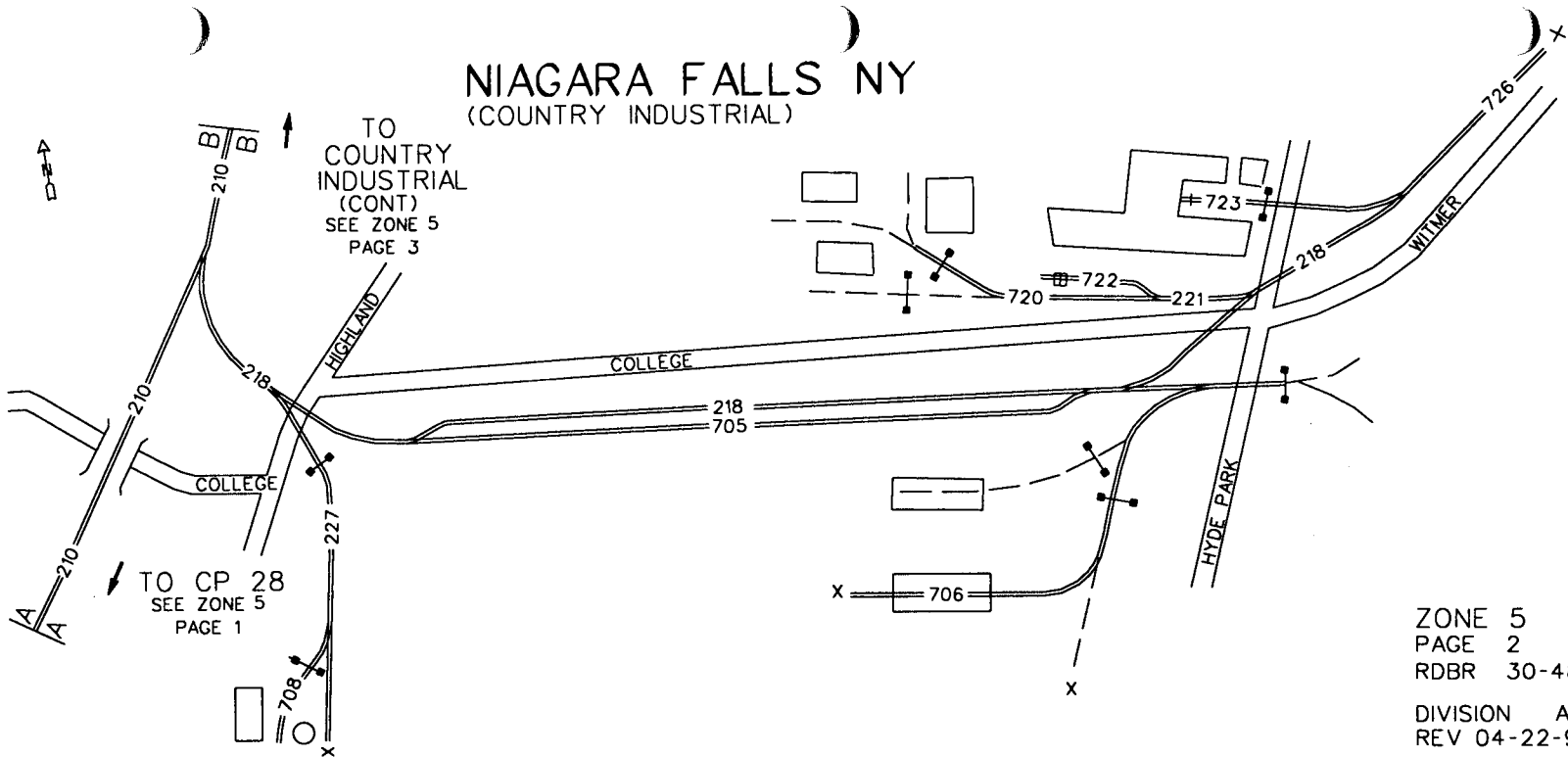

ZONE 5  
PAGE 2  
RDBR 30-4848

DIVISION ALBANY  
REV 04-22-96

ZONE 5

Rev 12/12/96

PAGE 3

|   |     |    |    |                            |
|---|-----|----|----|----------------------------|
| 5 | 210 | 00 | 00 | Country Ind.               |
| 5 | 222 | 00 | 00 | Ind. Lead - Tk.            |
| 5 | 730 | 01 | 01 | Tam Ceramics               |
| 5 | 731 | 01 | 04 | Tam Ceramics Tk.#1         |
| 5 | 732 | 01 | 02 | Tam Ceramics Tk.#2         |
| 5 | 733 | 01 | 02 | Tam Ceramics Tk.#3         |
| 5 | 735 | 99 | 99 | Niagara Mohawk Power - Tk. |
| 5 | 738 | 99 | 99 | Greif Bros Co.             |



# NIAGARA FALLS NY

(COUNTRY INDUSTRIAL)

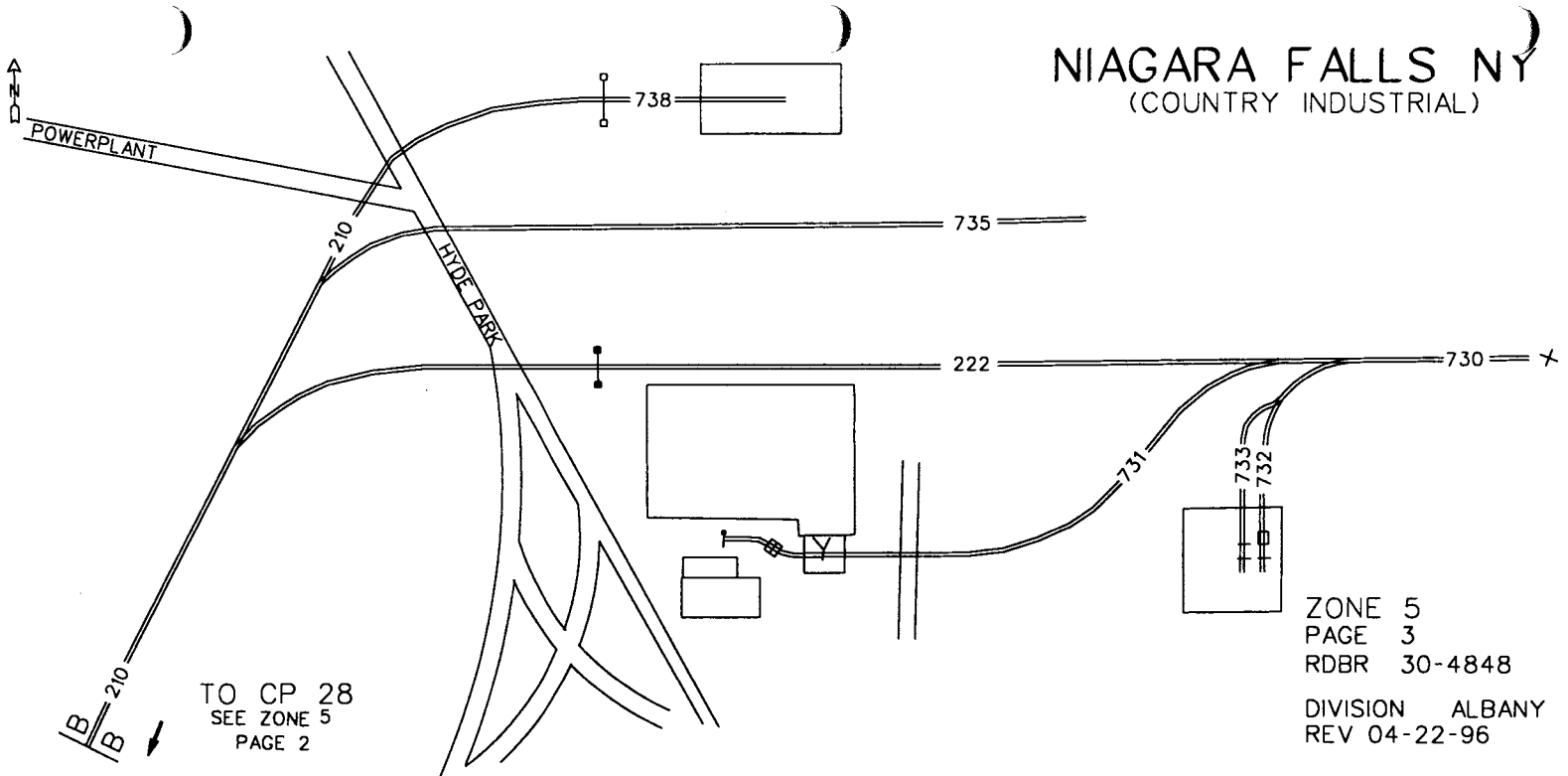

TO CP 28  
SEE ZONE 5  
PAGE 2

ZONE 5  
PAGE 3  
RDBR 30-4848

DIVISION ALBANY  
REV 04-22-96

|   |     |    |    |   |
|---|-----|----|----|---|
| 5 | 211 | 00 | 00 | Niagara - Branch - Tk.#1                |
| 5 | 212 | 00 | 00 | Niagara - Branch - Tk.#2                |
| 5 | 213 | 00 | 00 | Bridge - Branch                         |
| 5 | 214 | 00 | 00 | Main - Lead                             |
| 5 | 216 | 00 | 00 | Shop - Lead                             |
| 5 | 217 | 00 | 00 | Eng. House - Lead                       |
| 5 | 219 | 00 | 00 | Yd. Lead                                |
| 5 | 225 | 00 | 00 | Wye Track                               |
| 5 | 237 | 00 | 00 | South - Runner                          |
| 5 | 238 | 00 | 00 | North - Runner                          |
| 5 | 238 | 01 | 18 | Sevenson Enviromental (Lease 1000 Ft)   |
| 5 | 243 | 00 | 00 | Wye Tk.                                 |
| 5 | 244 | 00 | 00 | Wye Tk.                                 |
| 5 | 246 | 00 | 00 | Niagara - Yd. Lead                      |
| 5 | 251 | 00 | 00 | Lead - Tk.#1                            |
| 5 | 252 | 00 | 00 | Lead - Tk.#2                            |
| 5 | 253 | 00 | 00 | Lead - Tk.#3                            |
| 5 | 254 | 00 | 00 | Lead - Tk.#4                            |
| 5 | 255 | 00 | 00 | Lead - Tk.#5                            |
| 5 | 256 | 00 | 00 | Lead                                    |
| 5 | 257 | 00 | 00 | Scale - Tk.                             |
| 5 | 259 | 00 | 00 | Niagara Jct. Ind.                       |
| 5 | 501 | 00 | 00 | Repair Shed - Tk.                       |
| 5 | 502 | 00 | 00 | Wheel - Tk.                             |
| 5 | 503 | 00 | 00 | Shop - Tk.                              |
| 5 | 541 | 00 | 00 | North - Cab. Tk.                        |
| 5 | 542 | 00 | 00 | South - Cab. Tk.                        |
| 5 | 543 | 00 | 00 | Diesel - Tk.#1                          |
| 5 | 544 | 00 | 00 | Diesel - Tk.#2                          |
| 5 | 545 | 00 | 00 | Sand Pit                                |
| 5 | 546 | 00 | 00 | Pit - Tk.                               |
| 5 | 601 | 00 | 00 | Niagara - Yd. Tk.#1                     |
| 5 | 602 | 00 | 00 | Niagara - Yd. Tk.#2                     |
| 5 | 603 | 00 | 00 | Niagara - Yd. Tk.#3                     |
| 5 | 604 | 00 | 00 | Niagara - Yd. Tk.#4                     |
| 5 | 605 | 00 | 00 | Niagara - Yd. Tk.#5                     |
| 5 | 606 | 00 | 00 | Niagara - Yd. Tk.#6                     |
| 5 | 607 | 00 | 00 | Niagara - Yd. Tk.#7                     |
| 5 | 608 | 00 | 00 | Niagara - Yd. Tk.#8                     |
| 5 | 609 | 00 | 00 | Niagara - Yd. Tk.#9                     |
| 5 | 609 | 01 | 18 | Goodyear Tire & Rubber (Lease 1000 Ft.) |
| 5 | 610 | 00 | 00 | Niagara - Yd. Tk.#10                    |
| 5 | 611 | 00 | 00 | Niagara - Yd. Tk.#11                    |
| 5 | 612 | 00 | 00 | Niagara - Yd. Tk.#12                    |
| 5 | 613 | 00 | 00 | Niagara - Yd. Tk.#13                    |

5 614 00 00 Niagara - Yd. Tk.#14  
 5 615 00 00 Niagara - Yd. Tk.#15  
 5 615 01 17 Occidental Chemical - (Lease 984 Ft.)  
 5 616 00 00 Niagara - Yd. Tk.#16  
 5 617 00 00 Niagara - Yd. Tk.#17  
 5 618 00 00 Niagara - Yd. Tk.#18  
 5 618 99 99 Olin Corp. (Lease 19000 Ft.)  
 5 619 00 00 Niagara - Yd. Tk.#19  
 5 620 00 00 Niagara - Yd. Tk.#20  
 5 621 00 00 Niagara - Yd. Tk.#21  
 5 622 00 00 Niagara - Yd. Tk.#22  
 5 623 00 00 Niagara - Yd. Tk.#23  
 5 624 00 00 Niagara - Yd. Tk.#24  
 5 625 00 00 Niagara - Yd. Tk.#25  
 5 626 00 00 Niagara - Yd. Tk.#26  
 5 627 00 00 Niagara - Yd. Tk.#27  
 5 628 00 00 Niagara - Yd. Tk.#28  
 5 629 00 00 Niagara - Yd. Tk.#29  
 5 630 00 00 Niagara - Yd. Tk.#30  
 5 631 00 00 Niagara - Yd. Tk.#31  
 5 632 00 00 Niagara - Yd. Tk.#32  
 5 633 00 00 Niagara - Yd. Tk.#33  
 5 634 00 00 Niagara - Yd. Tk.#34  
 5 635 00 00 Niagara - Yd. Tk.#35  
 5 636 00 00 Niagara - Yd. Tk.#36  
 5 641 00 00 Niagara - Hold - Yd. Tk.#1  
 5 642 00 00 Niagara - Hold - Yd. Tk.#2  
 5 643 00 00 Niagara - Hold - Yd. Tk.#3  
 5 644 00 00 Niagara - Hold - Yd. Tk.#4  
 5 644 01 04 Occidental Chemical - (Lease 220 Ft.)  
 5 645 00 00 Niagara - Hold - Yd. Tk.#5  
 5 646 00 00 Niagara - Hold - Yd. Tk.#6  
 5 647 00 00 Niagara - Hold - Yd. Tk.#7  
 5 648 00 00 Niagara - Hold - Yd. Tk.#8  
 5 740 99 99 Vacant  
 5 742 97 97 (Team Tk.)  
 5 742 97 97 Apple Construction Ex  
 5 754 99 99 Amtrak  
 5 755 01 05 Amtrak

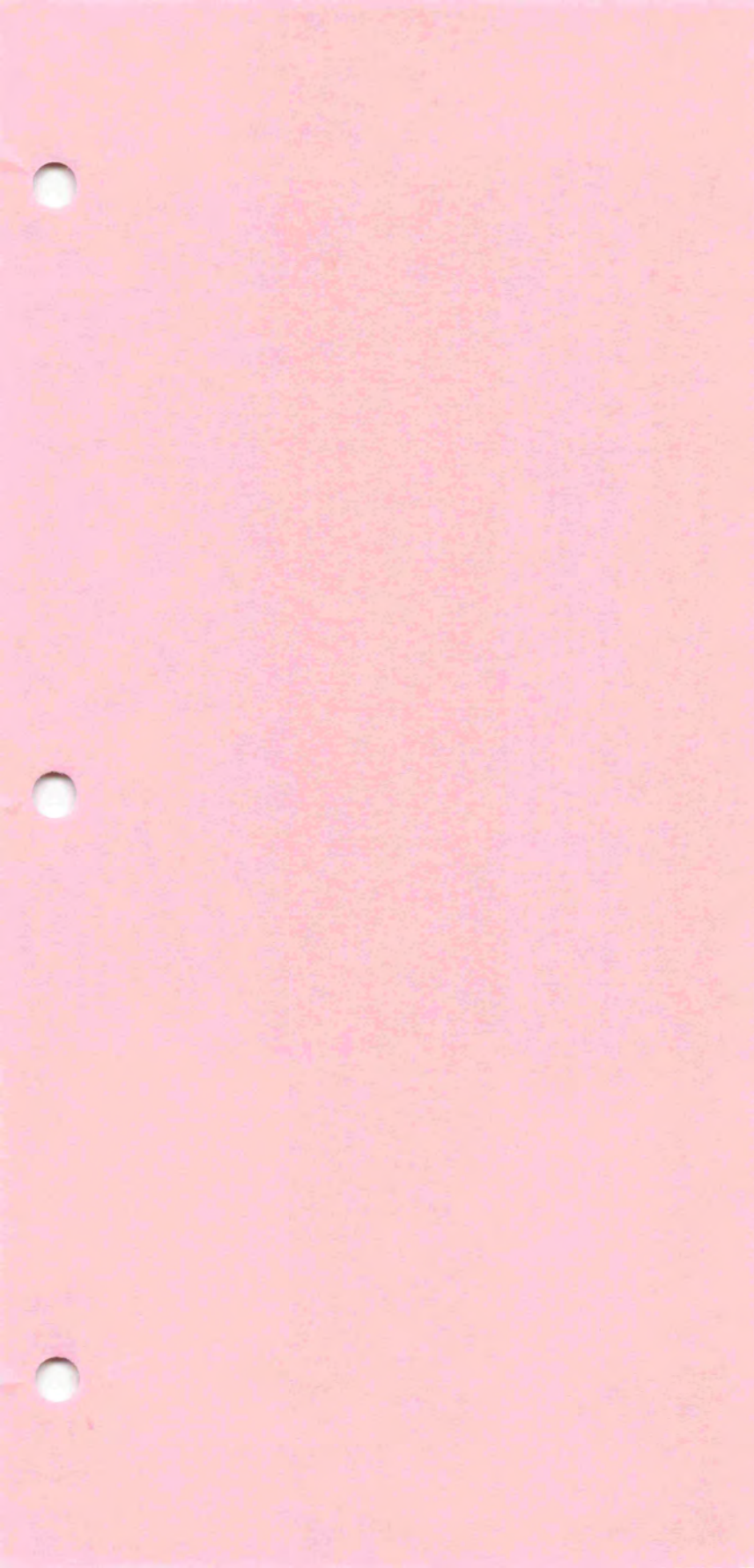

05 259 00 00 Niagara Jct. Ind.  
05 914 00 00 Olin Corp. Foote - Yd. Tk.#4  
05 915 00 00 Olin Corp. Foote - Yd. Tk.#5  
05 917 00 00 Olin Corp. Foote - Yd. Tk.#6  
05 918 00 00 Olin Corp. Foote - Yd. Tk.#7  
05 921 00 00 Olin Corp. Foote - Yd. Tk.#1  
05 922 00 00 Olin Corp. Foote - Yd. Tk.#2  
05 923 00 00 Olin Corp. Foote - Yd. Tk.#3

# NIAGARA FALLS NY

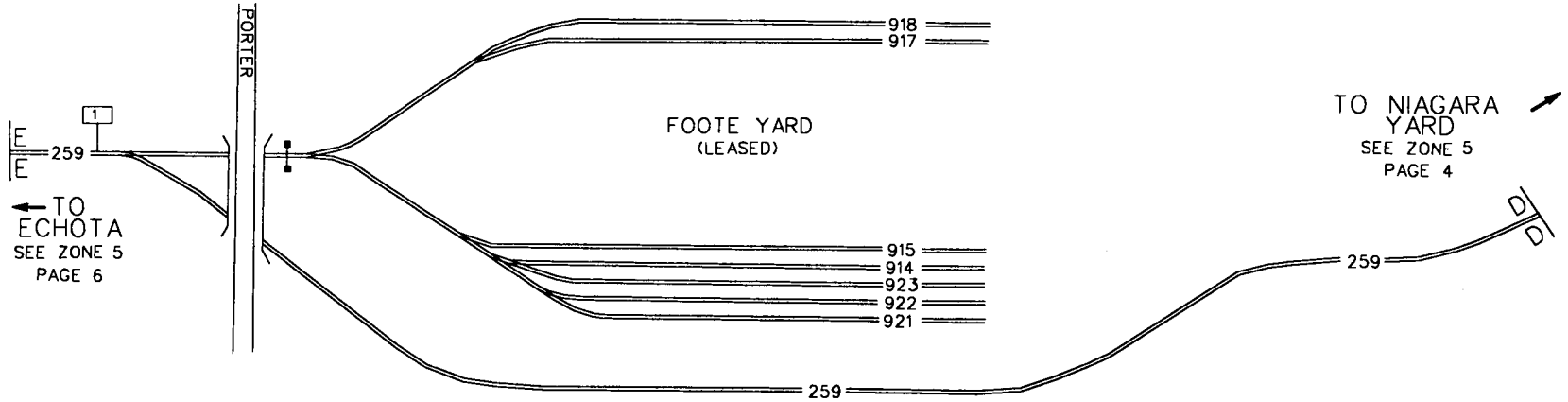

ZONE 5  
PAGE 5  
RDBR 30-4898  
DIVISION ALBANY  
REV 02-02-94

- 5 259 00 00 Niagara Jct. Ind.
- 5 261 00 00 Runaround
- 5 262 00 00 Ind. Lead - Tk.
- 5 263 00 00 Ind. Lead - Tk.
- 5 746 01 05 Occidental Chemical - (Durez)
- 5 747 99 99 Occidental Chemical - (Durez)
- 5 750 99 99 BFI
- 5 763 99 99 Airco Speer Carbon - Tk.(C)
- 5 764 01 03 Airco Speer Carbon - Tk.(D)
- 5 771 99 99 SGL Carbon
- 5 772 99 99 SGL Carbon
- 5 773 01 01 SGL Carbon
- 5 774 01 01 SGL Carbon
- 5 775 01 01 SGL Carbon
- 5 776 99 99 SGL Carbon
- 5 777 99 99 SGL Carbon
- 5 778 01 01 SGL Carbon

# N. GARA FALLS NY

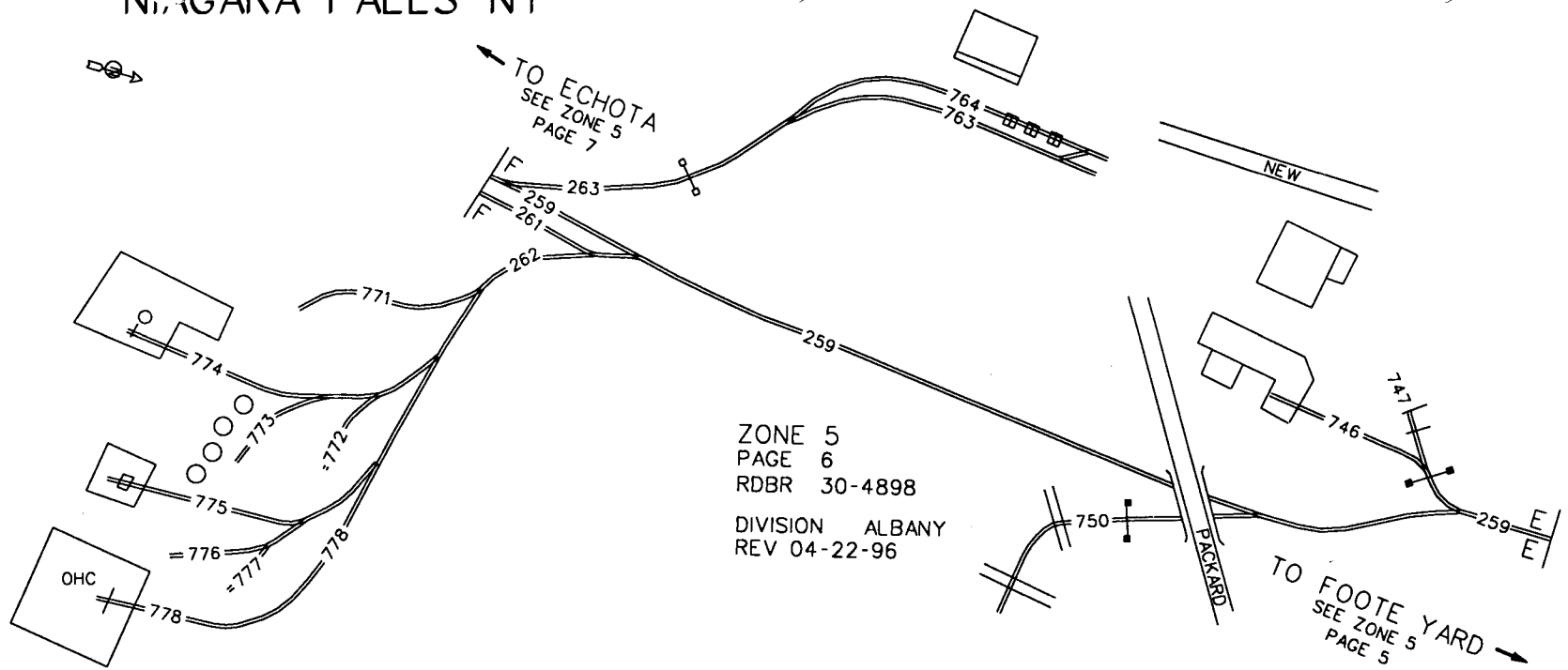

TO ECHOTA  
SEE ZONE 5  
PAGE 7

ZONE 5  
PAGE 6  
RDBR 30-4898  
DIVISION ALBANY  
REV 04-22-96

TO FOOTE YARD  
SEE ZONE 5  
PAGE 5



|   |     |    |    |                                    |
|---|-----|----|----|------------------------------------|
| 5 | 259 | 00 | 00 | Niagara Jct. Ind.                  |
| 5 | 261 | 00 | 00 | Runaround                          |
| 5 | 264 | 00 | 00 | Hooker - Connection - Tk.          |
| 5 | 266 | 00 | 00 | Ind. Lead - Tk.                    |
| 5 | 268 | 00 | 00 | Ind. Lead - Tk.                    |
| 5 | 701 | 99 | 99 | United Dev.Group Loco Tk.          |
| 5 | 702 | 99 | 99 | United Dev.Group Heater Shed       |
| 5 | 703 | 99 | 99 | United Dev.Group Straight Tk.      |
| 5 | 781 | 01 | 02 | Goodyear Tire & Rubber - Tk.#1     |
| 5 | 782 | 99 | 99 | Goodyear Tire & Rubber - Tk.#2     |
| 5 | 783 | 99 | 99 | Goodyear Tire & Rubber - Tk.#3     |
| 5 | 787 | 99 | 99 | Occidental Chemical - (Leased Tk.) |
| 5 | 788 | 99 | 99 | Occidental Chemical - Tk.#18       |
| 5 | 789 | 99 | 99 | Occidental Chemical - Tk.#19       |
| 5 | 790 | 99 | 99 | L-Tech Welding & Cutting           |
| 5 | 792 | 01 | 03 | Niacet                             |
| 5 | 793 | 01 | 07 | Niacet                             |
| 5 | 794 | 01 | 01 | Niacet                             |
| 5 | 796 | 99 | 99 | Sentry Metal Blast                 |
| 5 | 798 | 01 | 03 | Occidental Chemical - Tk.(S)       |
| 5 | 800 | 01 | 01 | Occidental Chemical - Tk.(T)       |

# NIAGARA FALLS NY (ECHOTA)

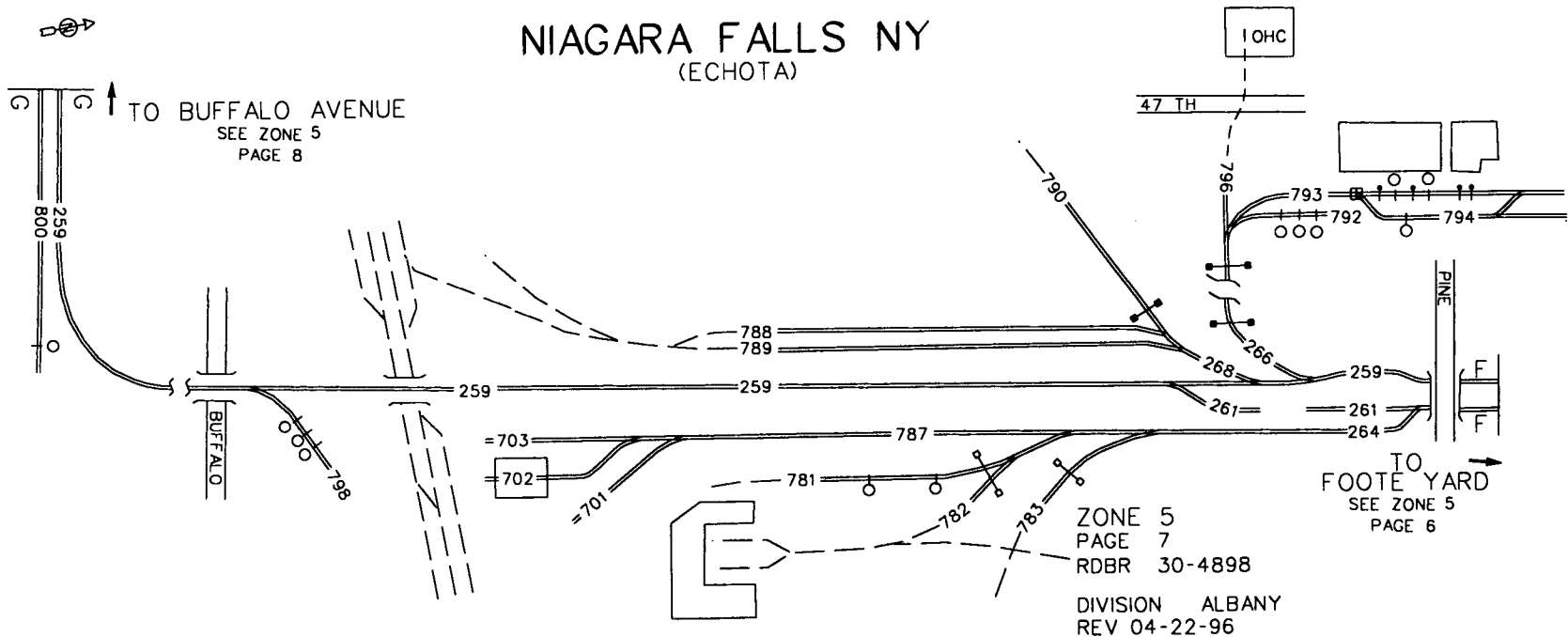

TO BUFFALO AVENUE  
SEE ZONE 5  
PAGE 8

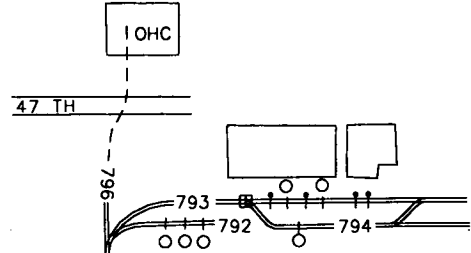

TO  
FOOTE YARD  
SEE ZONE 5  
PAGE 6

ZONE 5  
PAGE 7  
RDBR 30-4898  
DIVISION ALBANY  
REV 04-22-96

|   |     |    |    |                                      |
|---|-----|----|----|--------------------------------------|
| 5 | 259 | 00 | 00 | Niagara Jct. Ind.                    |
| 5 | 275 | 00 | 00 | Niagara Jct. Tk.#5                   |
| 5 | 800 | 01 | 01 | Occidental Chemical - Tk.(T)         |
| 5 | 801 | 99 | 99 | Occidental Chemical - Tk.#2          |
| 5 | 802 | 99 | 99 | Occidental Chemical - Scale Tk.      |
| 5 | 803 | 99 | 99 | Occidental Chemical - Caustic Tk.#1  |
| 5 | 811 | 99 | 99 | Occidental Chemical - Tk.#3          |
| 5 | 812 | 99 | 99 | Occidental Chemical - Tk.#4          |
| 5 | 813 | 99 | 99 | Occidental Chemical - Tk.#5          |
| 5 | 822 | 99 | 99 | Occidental Chemical - Tk.(I)         |
| 5 | 823 | 99 | 99 | Occidental Chemical - Tk.(G)         |
| 5 | 824 | 99 | 99 | Occidental Chemical - Tk.(W)         |
| 5 | 825 | 99 | 99 | Occidental Chemical - Government Tk. |
| 5 | 832 | 99 | 99 | Occidental Chemical - River (J) Tk.  |
| 5 | 833 | 01 | 03 | Occidental Chemical - Tk.(X)         |
| 5 | 834 | 01 | 02 | Alox                                 |
| 5 | 840 | 99 | 99 | Allwaste Container Services - Tk.#0  |
| 5 | 841 | 99 | 99 | Allwaste Container Services - Tk.#1  |
| 5 | 842 | 99 | 99 | Allwaste Container Services - Tk.#2  |
| 5 | 843 | 99 | 99 | Allwaste Container Services - Tk.#3  |
| 5 | 844 | 99 | 99 | Allwaste Container Services - Tk.#4  |
| 5 | 845 | 99 | 99 | Allwaste Container Services - Tk.#5  |
| 5 | 846 | 99 | 99 | Allwaste Container Services - Tk.#6  |
| 5 | 847 | 99 | 99 | Allwaste Container Services - Tk.#7  |
| 5 | 848 | 99 | 99 | Allwaste Container Services - Tk.#8  |
| 5 | 849 | 99 | 99 | Allwaste Container Services - Tk.#9  |

# NIAGARA FALLS NY

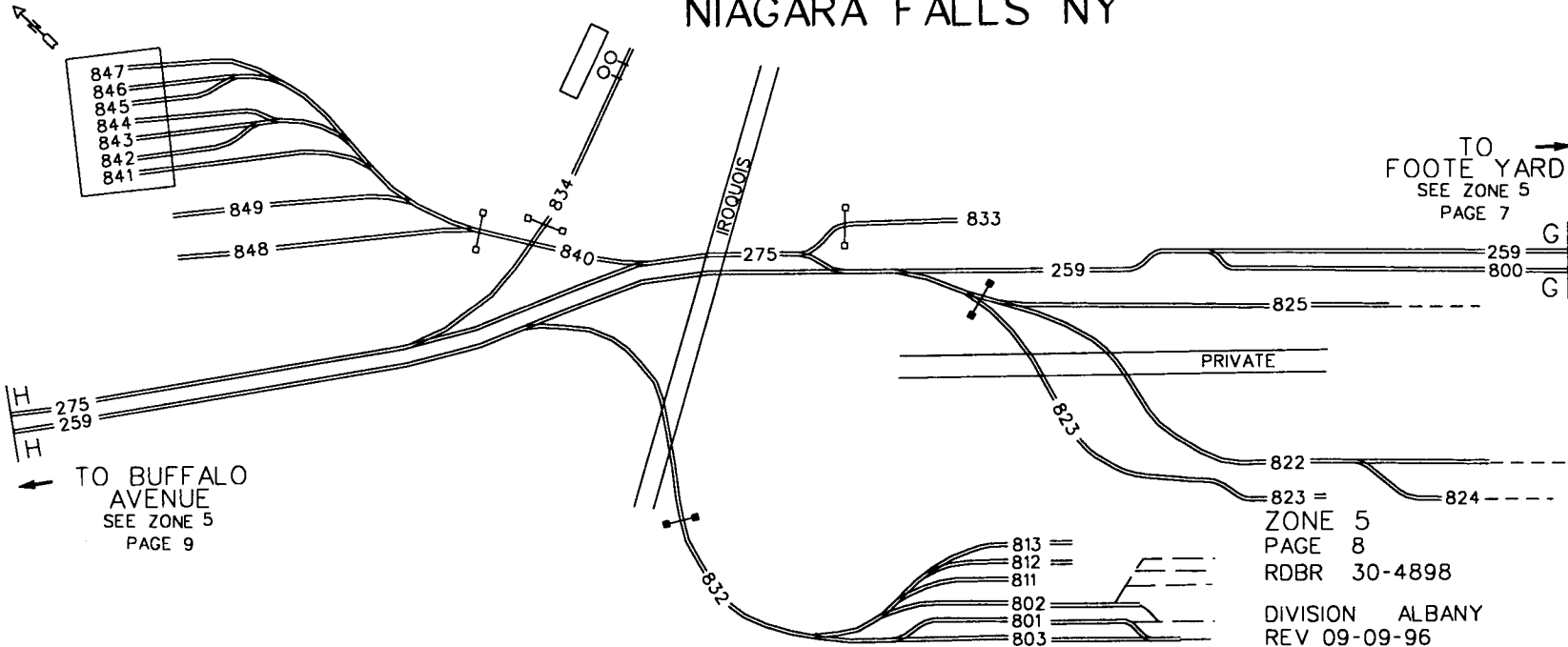

TO  
FOOTE YARD  
SEE ZONE 5  
PAGE 7

TO BUFFALO  
AVENUE  
SEE ZONE 5  
PAGE 9

823 =  
ZONE 5  
PAGE 8  
RDBR 30-4898

DIVISION ALBANY  
REV 09-09-96

5 259 00 00 Niagara Jct. Ind.  
5 270 00 00 Down 8  
5 272 00 00 Ind. Lead - Tk.  
5 274 00 00 Niagara Jct. Tk.#4  
5 275 00 00 Niagara Jct. Tk.#5  
5 278 00 00 Ind. Lead - Tk.  
5 686 00 00 Gill Creek - Yd. Tk.#6  
5 686 97 97 Matlack  
5 688 00 00 Gill Creek - Yd. Tk.#7  
5 851 99 99 E.I. Dupont - Tk.#V 1  
5 852 01 09 E.I. Dupont - Tk.#V 2  
5 853 01 01 Vacant  
5 854 99 99 E.I. Dupont - Tk.#174A  
5 855 99 99 E.I. Dupont - Tk.#174B  
5 856 01 02 E.I. Dupont - Tk.#(DN)  
5 868 01 01 E.I. Dupont - Tk.(A) #1  
5 869 01 02 E.I. Dupont - Tk.(A) #2  
5 870 99 99 E.I. Dupont - Tk.(B)  
5 871 01 02 E.I. Dupont - Tk.(B) #1  
5 872 01 01 E.I. Dupont - Tk.(B) #2  
5 873 01 01 E.I. Dupont - Tk.(B) #3  
5 874 99 99 E.I. Dupont - Tk.(B) #4  
5 875 99 99 E.I. Dupont - (A) - Spur  
5 876 01 03 E.I. Dupont - Tk.(E) #1  
5 877 99 99 E.I. Dupont - Tk.(E) #2  
5 878 99 99 E.I. Dupont - Tk.(E) #3  
5 879 99 99 E.I. Dupont - Tk.(E) #4  
5 880 01 02 Olin Corp. Tk.(I) South  
5 881 99 99 Olin Corp. Tk.(F)  
5 882 01 05 Olin Corp. Tk.(G)  
5 883 01 05 Olin Corp. Tk.(H)  
5 884 99 99 Olin Corp. Tk.(I) Middle  
5 885 01 02 Olin Corp. Tk.(I) North  
5 886 01 03 Olin Corp. (J) Spur  
5 887 99 99 Olin Corp. Tk.(A) - Empty  
5 888 99 99 Olin Corp. Tk.(A) - Full  
5 889 01 01 Olin Corp. Salt Tk.  
5 890 99 99 Olin Corp. (BPRR) - West Tk.#3  
5 891 99 99 Olin Corp. (BPRR) - East Tk.#2  
5 892 99 99 Olin Corp. (BPRR) - Creek Tk.#1  
5 894 99 99 Olin Corp. X-Over Tk.

# NIAGARA FALLS NY

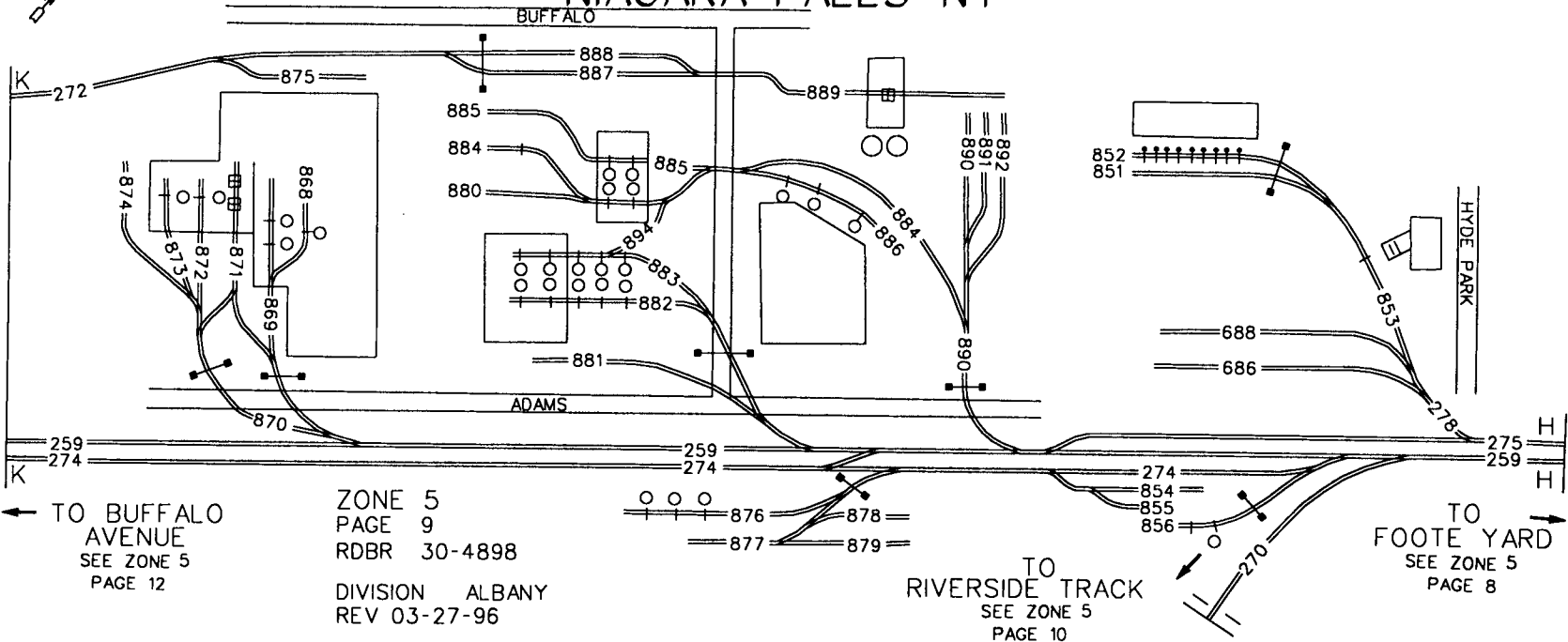

ZONE 5  
PAGE 9  
RDBR 30-4898

DIVISION ALBANY  
REV 03-27-96

TO BUFFALO AVENUE  
SEE ZONE 5  
PAGE 12

TO RIVERSIDE TRACK  
SEE ZONE 5  
PAGE 10

TO FOOTE YARD  
SEE ZONE 5  
PAGE 8

ZONE 5

Rev 12/26/96

PAGE 10

- 5 270 00 00 Riverside - Tk. (Down 8)
- 5 850 99 99 E.I. Dupont - (JE) Stg. Tk./ Tk.(N)
- 5 857 01 02 E.I. Dupont - Tk.#(T) North
- 5 858 01 02 E.I. Dupont - Tk.#(T) South
- 5 859 01 01 E.I. Dupont - Tk.(R)
- 5 860 01 04 E.I. Dupont - Tk.(H)
- 5 862 99 99 E.I. Dupont - Tk.
- 5 863 01 04 E.I. Dupont - (K) - Tk.#1
- 5 864 01 04 E.I. Dupont - (K) - Tk.#2

D-27

# NIAGARA FALLS NY (RIVERSIDE TRACK)

TO NIAGARA FALLS  
(CONT)  
SEE ZONE 5  
PAGE 9

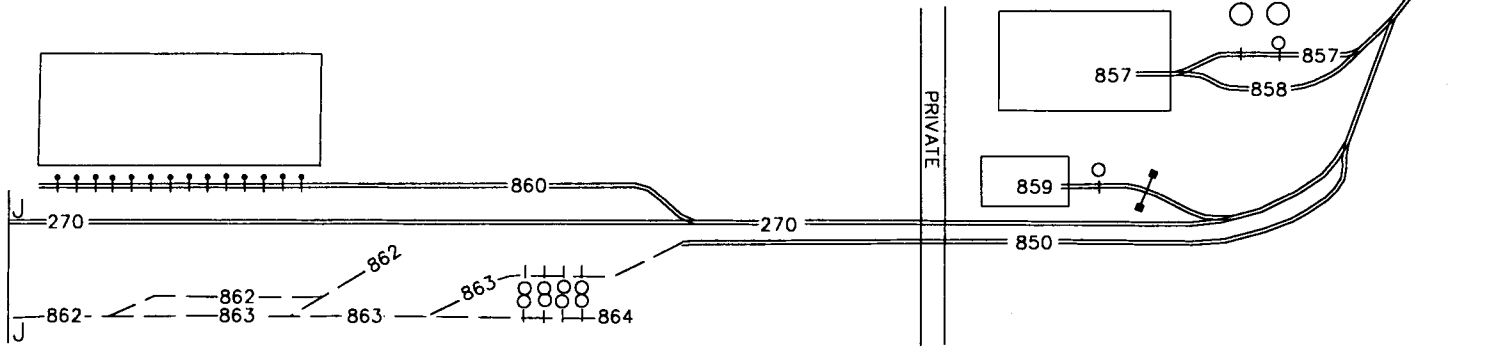

← TO  
RIVERSIDE TRACK  
(CONT)  
SEE ZONE 5  
PAGE 11

ZONE 5  
PAGE 10  
RDBR 30-4898

DIVISION ALBANY  
REV 04-22-96



ZONE 5

Rev 2/13/97

PAGE 11

5 270 00 00 Down 8  
5 862 99 99 E.I. Dupont - Tk.  
5 865 99 99 E.I. Dupont - (West Yard) - Tk.#1  
5 866 99 99 E.I. Dupont - (West Yard) - Tk.#2  
5 867 99 99 E.I. Dupont - (West Yard) - Tk.#3  
5 907 01 03 Sohio - Tk.#7  
5 908 99 99 Sohio - Tk.#8 - Jct.  
5 909 01 01 Sohio - Tk.#9  
5 910 01 04 Sohio - Navy South  
5 911 01 10 Sohio - Navy North  
5 925 01 03 Sohio - Tk.#25

# NIAGARA FALLS NY

(RIVERSIDE TRACK)

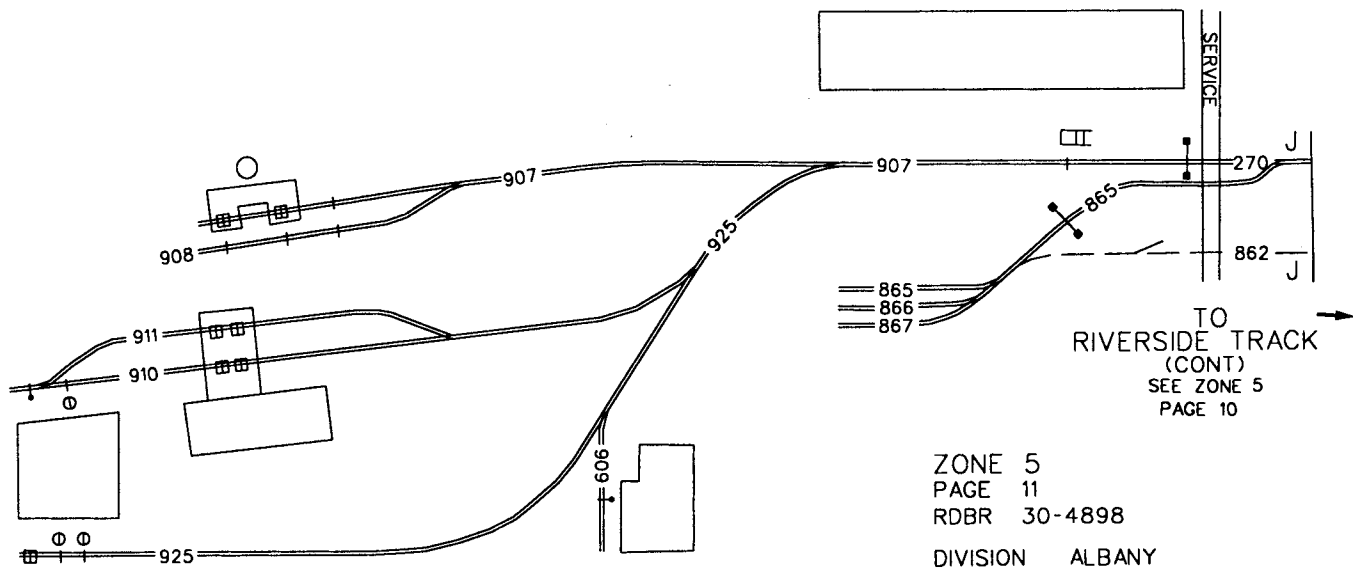

ZONE 5  
PAGE 11  
RDBR 30-4898  
DIVISION ALBANY  
REV 04-22-96

ZONE 5

Rev 12/12/96

PAGE 12

|   |     |    |    |                                |
|---|-----|----|----|--------------------------------|
| 5 | 259 | 00 | 00 | Niagara Jct. Ind.              |
| 5 | 271 | 00 | 00 | Ind. Lead - Tk.                |
| 5 | 272 | 00 | 00 | Ind. Lead - Tk.                |
| 5 | 274 | 00 | 00 | Niagara Jct. Tk.#4             |
| 5 | 906 | 01 | 07 | Sohio - Tk.#6                  |
| 5 | 931 | 01 | 03 | Niagara Falls City Waste Plant |
| 5 | 932 | 01 | 03 | Niagara Falls City Waste Plant |
| 5 | 933 | 01 | 04 | Niagara Falls City Waste Plant |
| 5 | 934 | 99 | 99 | Niagara Falls City Waste Plant |



# NIAGARA FALLS NY

(BUFFALO AVENUE)

TO NIAGARA FALLS  
(CONT)  
SEE ZONE 5  
PAGE 13

TO  
FOOTE YARD  
SEE ZONE 5  
PAGE 9

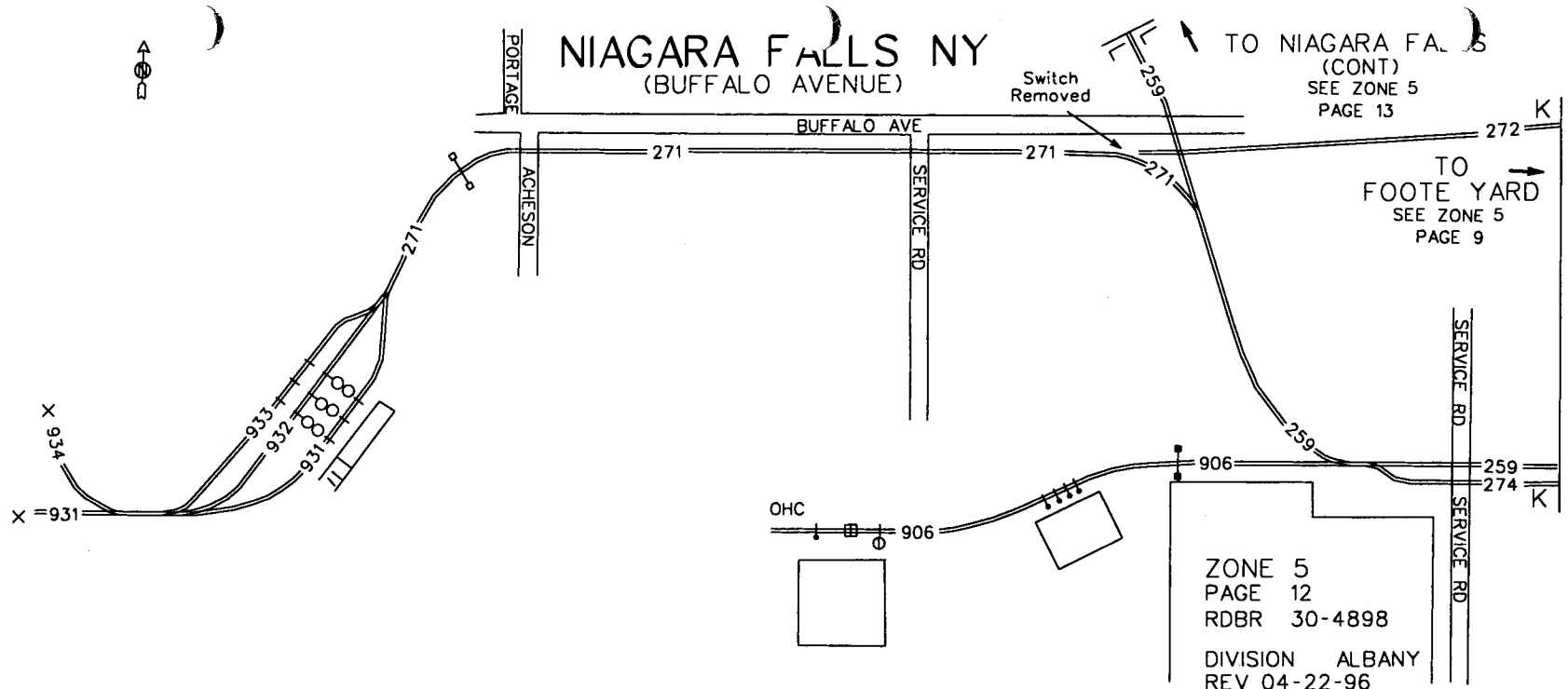

ZONE 5  
PAGE 12  
RDBR 30-4898  
DIVISION ALBANY  
REV 04-22-96

ZONE 5

Rev 12/12/96

PAGE 13

|   |     |    |    |                              |
|---|-----|----|----|------------------------------|
| 5 | 259 | 00 | 00 | Niagara Jct. Ind.            |
| 5 | 936 | 99 | 99 | Precision Electrode Minerals |
| 5 | 940 | 01 | 11 | Nabisco Brands Whse. Tk.#0   |
| 5 | 941 | 01 | 05 | Nabisco Brands Whse. Tk.#1   |
| 5 | 942 | 99 | 99 | Nabisco Brands Whse. Tk.#2   |
| 5 | 944 | 01 | 01 | Nabisco Brands Whse. Tk.#4   |
| 5 | 945 | 99 | 99 | Nabisco Brands Whse. Tk.#5   |
| 5 | 946 | 99 | 99 | Nabisco Brands Whse. Tk.Lead |

# NIAGARA FALLS NY

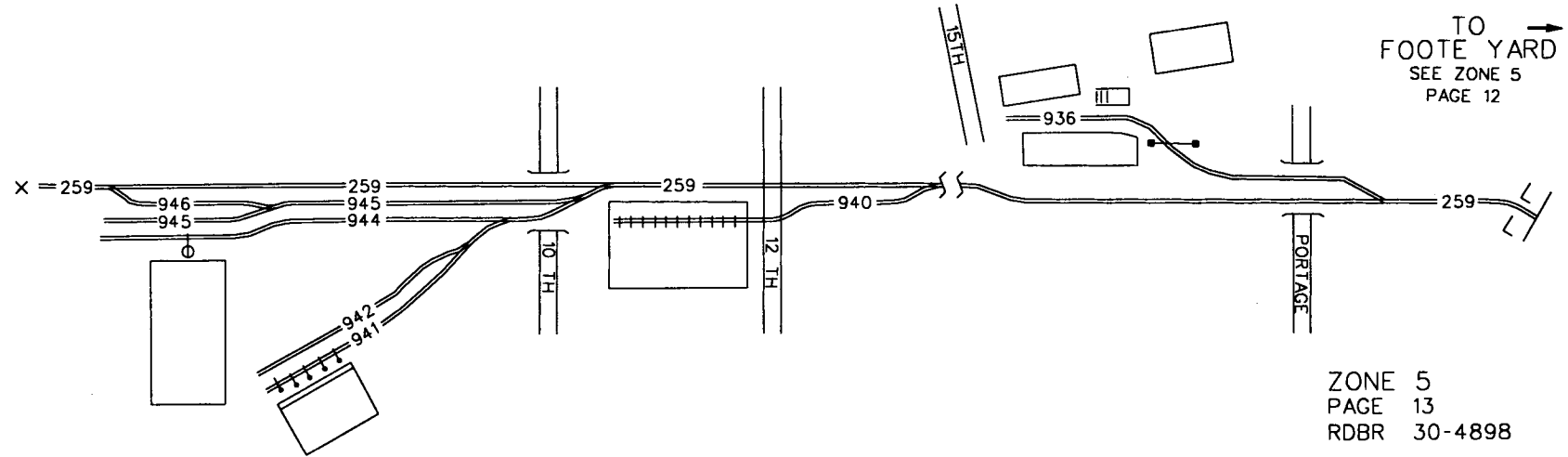

TO  
FOOTE YARD  
SEE ZONE 5  
PAGE 12

ZONE 5  
PAGE 13  
RDBR 30-4898

DIVISION ALBANY  
REV 03-28-96

ZONE 5

Rev 12/26/96

PAGE 14

- 5 211 00 00 Niagara - Branch - Tk.#1
- 5 212 00 00 Niagara - Branch - Tk.#2
- 5 213 00 00 Bridge - Branch
- 5 246 00 00 Niagara - Yd. Lead (Old Way)
- 5 949 01 02 Vacant

# NIAGARA FALLS NY

↑  
N  
D  
← TO  
NIAGARA YARD  
SEE ZONE 5  
PAGE 4

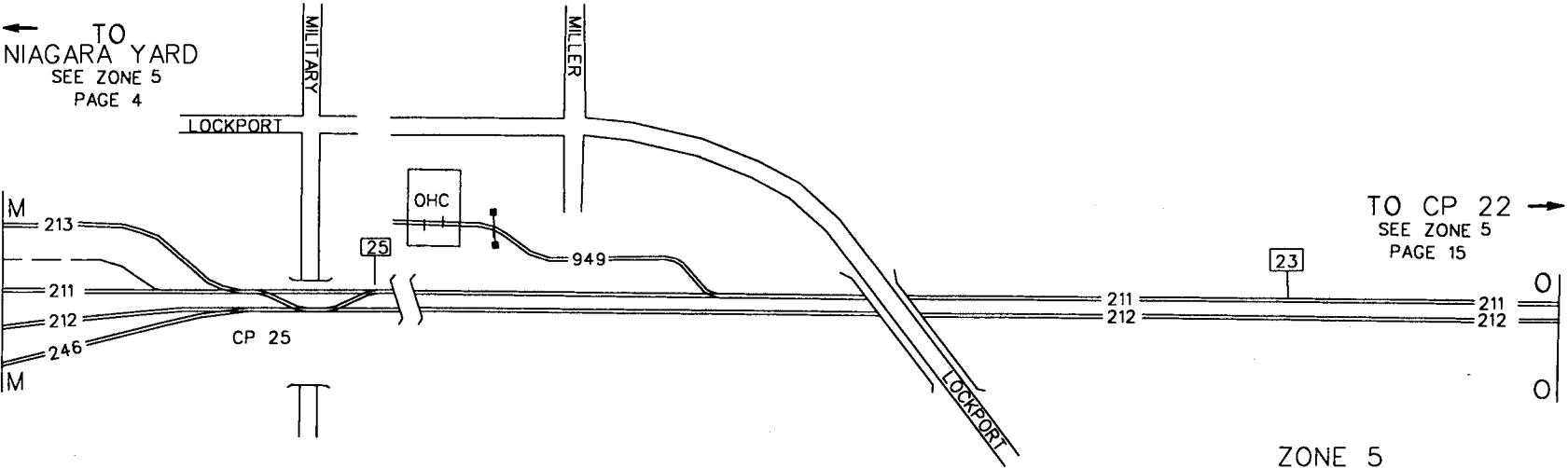

ZONE 5  
PAGE 14  
RDBR 30-4821 30-0615  
30-6461  
DIVISION ALBANY  
REV 01-28-97



ZONE 5

Rev 12/12/96

PAGE 15

- 5 211 00 00 Niagara - Branch - Tk.#1
- 5 212 00 00 Niagara - Branch - Tk.#2
- 5 223 00 00 Lockport - Branch
- 5 225 00 00 Tuscarora Wye Tk.
- 5 952 99 99 Sypass & Sons
- 5 953 01 02 Sypass & Sons
- 5 955 01 07 Sanborn Milling - Tk.



# WALMORE NY

# SANBORN NY

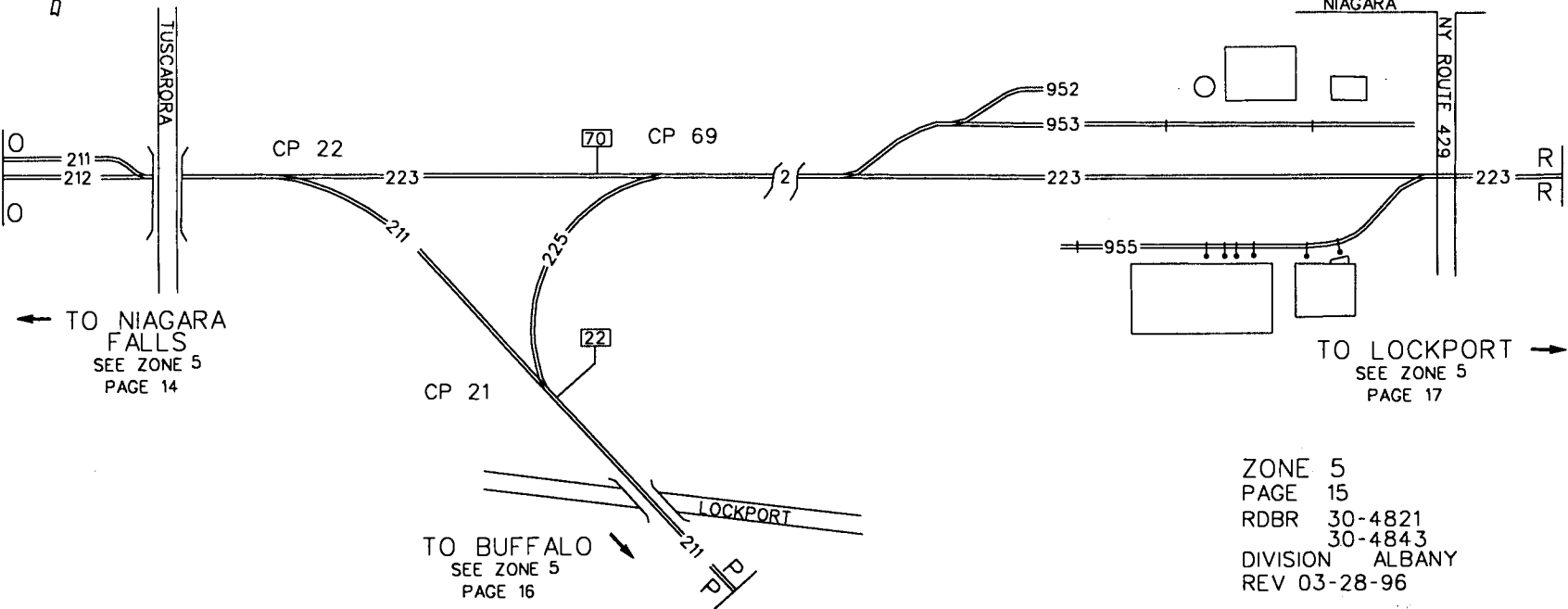

← TO NIAGARA  
FALLS  
SEE ZONE 5  
PAGE 14

TO BUFFALO  
SEE ZONE 5  
PAGE 16

TO LOCKPORT →  
SEE ZONE 5  
PAGE 17

ZONE 5  
PAGE 15  
RDBR 30-4821  
30-4843  
DIVISION ALBANY  
REV 03-28-96

ZONE 5

Rev 12/12/96

PAGE 16

5 211 00 00 Niagara - Branch - Tk.#1

5 212 00 00 Niagara - Branch - Tk.#2

WALMORE NY

WHEATFIELD NY



TO BUFFALO ↗  
SEE ZONE 4  
PAGE 1

↖ TO CP 21  
SEE ZONE 5  
PAGE 15

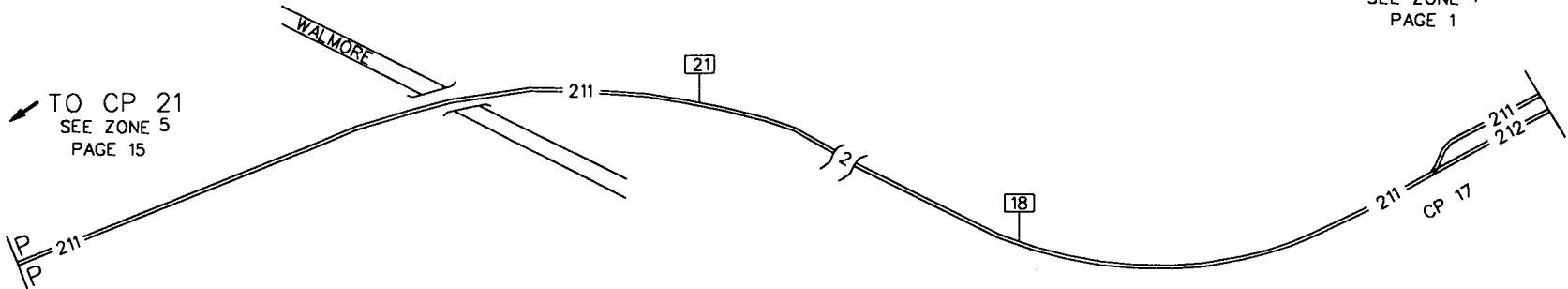

ZONE 5  
PAGE 16  
RDBR 30-4843

DIVISION ALBANY  
REV 03-28-96

ZONE 5

Rev 12/12/96

PAGE 17

|   |     |    |    |                                      |
|---|-----|----|----|--------------------------------------|
| 5 | 223 | 00 | 00 | Lockport - Branch                    |
| 5 | 281 | 00 | 00 | Jct. Tk.#1                           |
| 5 | 282 | 00 | 00 | Jct. Tk.#2                           |
| 5 | 957 | 01 | 01 | Scranton Thruway Builders            |
| 5 | 959 | 99 | 99 | Mill Street Recycling Inc.           |
| 5 | 960 | 01 | 03 | Modern Disposal Service (Lease150Ft) |
| 5 | 960 | 01 | 16 | Polycom Huntsman                     |
| 5 | 960 | 99 | 99 | New York State Gas & Elect           |

CAMBRIA NY

LOCKPORT NY



TO  
NIAGARA FALLS  
SEE ZONE 5  
PAGE 15

TO CP 59  
SEE ZONE 5  
PAGE 18

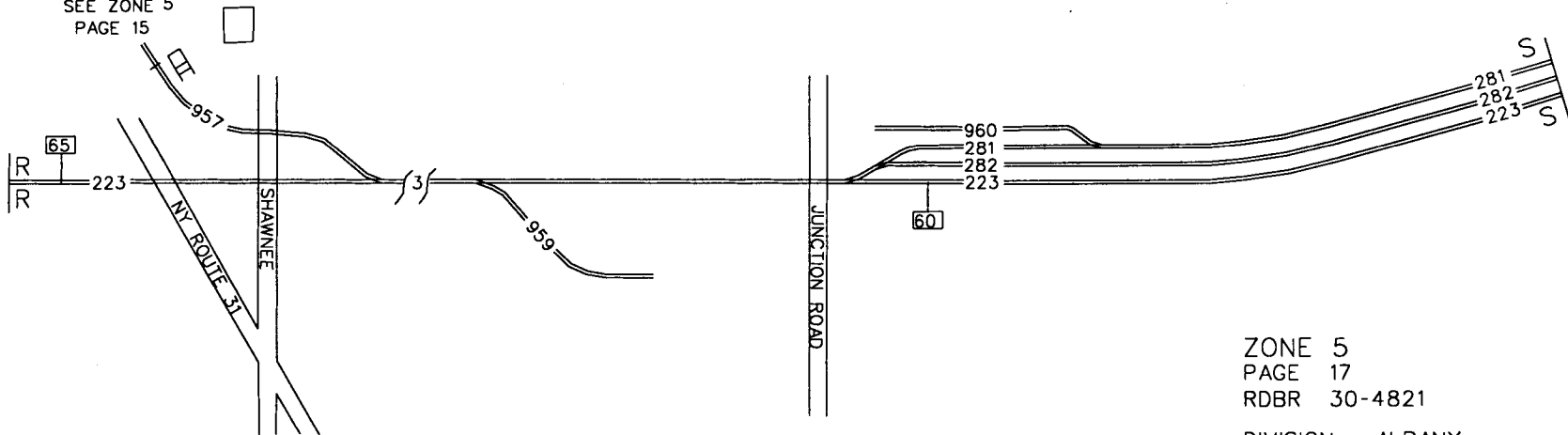

ZONE 5  
PAGE 17  
RDBR 30-4821

DIVISION ALBANY  
REV 02-02-94

ZONE 5

Rev 12/12/96

PAGE 18

|   |     |    |    |                                       |
|---|-----|----|----|---------------------------------------|
| 5 | 223 | 00 | 00 | Lockport - Branch                     |
| 5 | 281 | 00 | 00 | Jct. Tk.#1                            |
| 5 | 282 | 00 | 00 | Jct. Tk.#2                            |
| 5 | 285 | 00 | 00 | G.M. Siding                           |
| 5 | 954 | 99 | 99 | GM Harrison Lockport - Tk.#4 A        |
| 5 | 963 | 01 | 15 | GM Harrison Lockport - Tk.#3 Bldg #7  |
| 5 | 964 | 99 | 99 | GM Harrison Lockport - Tk.#4          |
| 5 | 965 | 01 | 18 | GM Harrison Lockport - Tk.#5 Bldg #10 |
| 5 | 966 | 01 | 18 | GM Harrison Lockport - Tk.#6 Bldg #10 |
| 5 | 967 | 01 | 04 | GM Harrison Lockport - Tk.#7          |
| 5 | 969 | 99 | 99 | GM Harrison Lockport - Tk.1 Lead      |
| 5 | 970 | 99 | 99 | GM Harrison Lockport - Tk.#4 D        |
| 5 | 974 | 99 | 99 | GM Harrison Lockport - Tk.#4 B        |
| 5 | 975 | 01 | 09 | GM Harrison Lockport - Tk.#5 Bldg #9  |
| 5 | 984 | 99 | 99 | GM Harrison Lockport - Tk.#4 C        |
| 5 | 994 | 01 | 01 | GM Harrison Lockport - Silo Tk.       |

# LOCKPORT NY

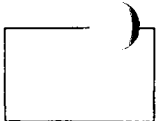

HARRISON RADIATOR

TO CP 59 →  
SEE ZONE 6  
PAGE 1

ZONE 5  
PAGE 18  
RDBR 30-4821

DIVISION ALBANY  
REV 03-28-96

UPPER MOUNTAIN

← TO  
NIAGARA FALLS  
SEE ZONE 5  
PAGE 17

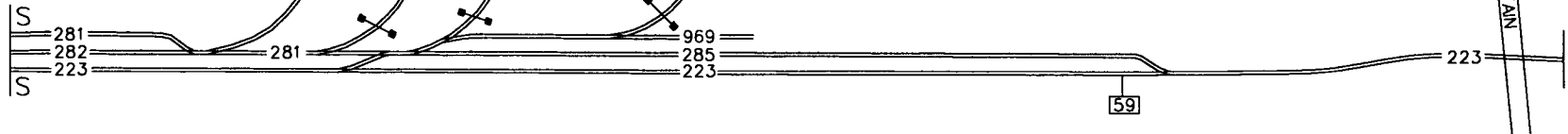



# LOCKPORT - ZONE 6

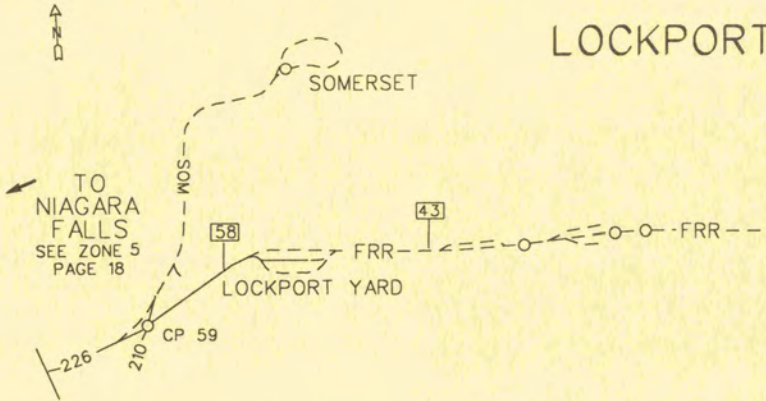

| TRACK SEGMENT          | ZTS TRK |
|------------------------|---------|
| GULF INDUSTRIAL        | 210     |
| LOCKPORT RUNNING TRACK | 214     |
| FALLS ROAD SECONDARY   | 226     |

ZONE 6

Rev 12/12/96

PAGE 1

6 210 00 00 Gulf Ind.  
6 226 00 00 Falls Road - Secondary  
6 606 00 00 (SOM) - Connection - Tk.  
6 701 01 01 Van De Mark Chemical - Tk.  
6 702 01 01 Van De Mark Chemical - Tk.  
6 703 01 01 Van De Mark Chemical - Tk.  
6 704 01 02 J.H.Products

# LOCKPORT NY

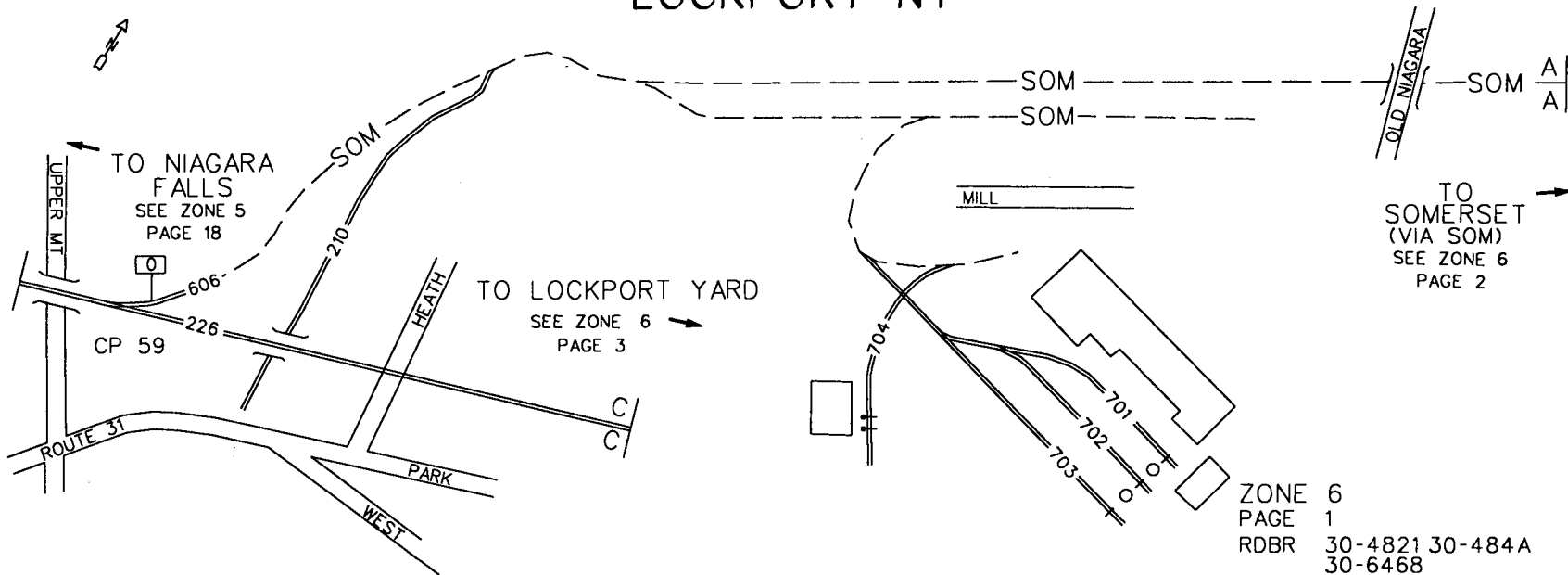

ZONE 6  
PAGE 1  
RDBR 30-4821 30-484A  
30-6468  
DIVISION ALBANY  
REV 01-28-97

ZONE 06

Rev 04/01/94

PAGE 2

06 708 99 99 New York State Gas & Elec- Limestone

06 709 99 99 New York State Gas & Elect - Coal #2

06 710 99 99 New York State Gas & Elect - Coal #1

06 711 99 99 New York State Gas & Elect - Conn Tk

# SOMERSET NY

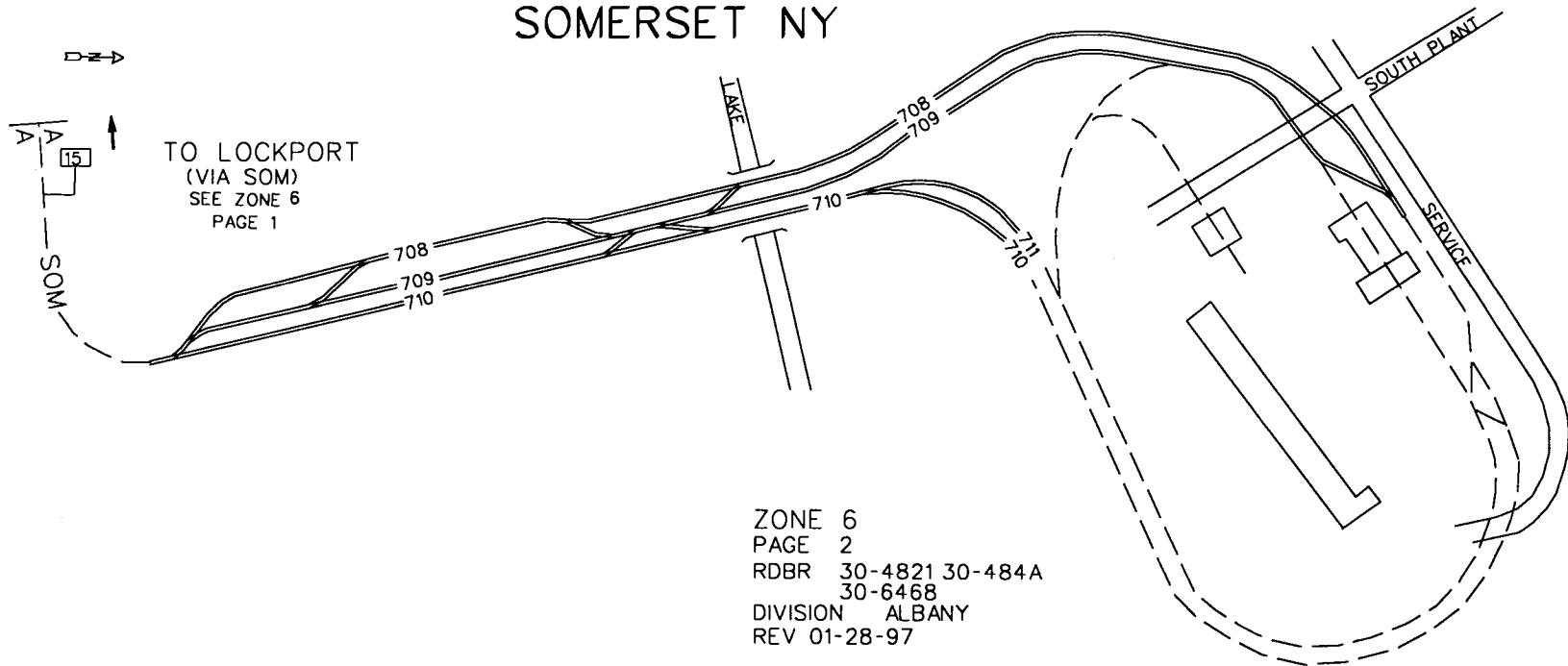

ZONE 6  
PAGE 2  
RDBR 30-4821 30-484A  
30-6468  
DIVISION ALBANY  
REV 01-28-97

ZONE 6

Rev 12/26/96

PAGE 3

6 226 00 00 Falls Road - Secondary

6 621 00 00 (FRR) - I/C Tk.

# LOCKPORT NY

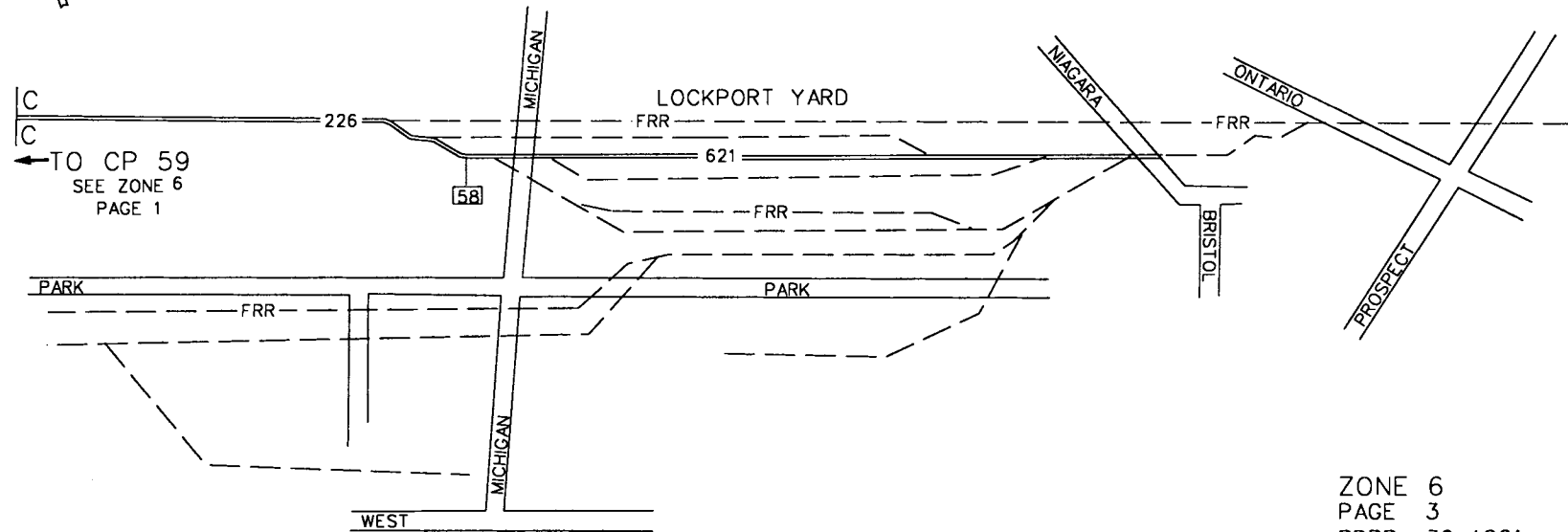

ZONE 6  
PAGE 3  
RDBR 30-4821

DIVISION ALBANY  
REV 11-01-96



# ROCHESTER-ZONE 7

| TRACK SEGMENT           | ZTS TRK |
|-------------------------|---------|
| CHICAGO LINE            | 201     |
| WEST SHORE BRANCH       | 208     |
| FALLS ROAD SECONDARY    | 226     |
| CHARLOTTE RUNNING TRACK | 242     |
| OLD LINE IND LEAD       | 249     |
| CHARLOTTE INDUSTRIAL    | 256     |

REV 12-12-96

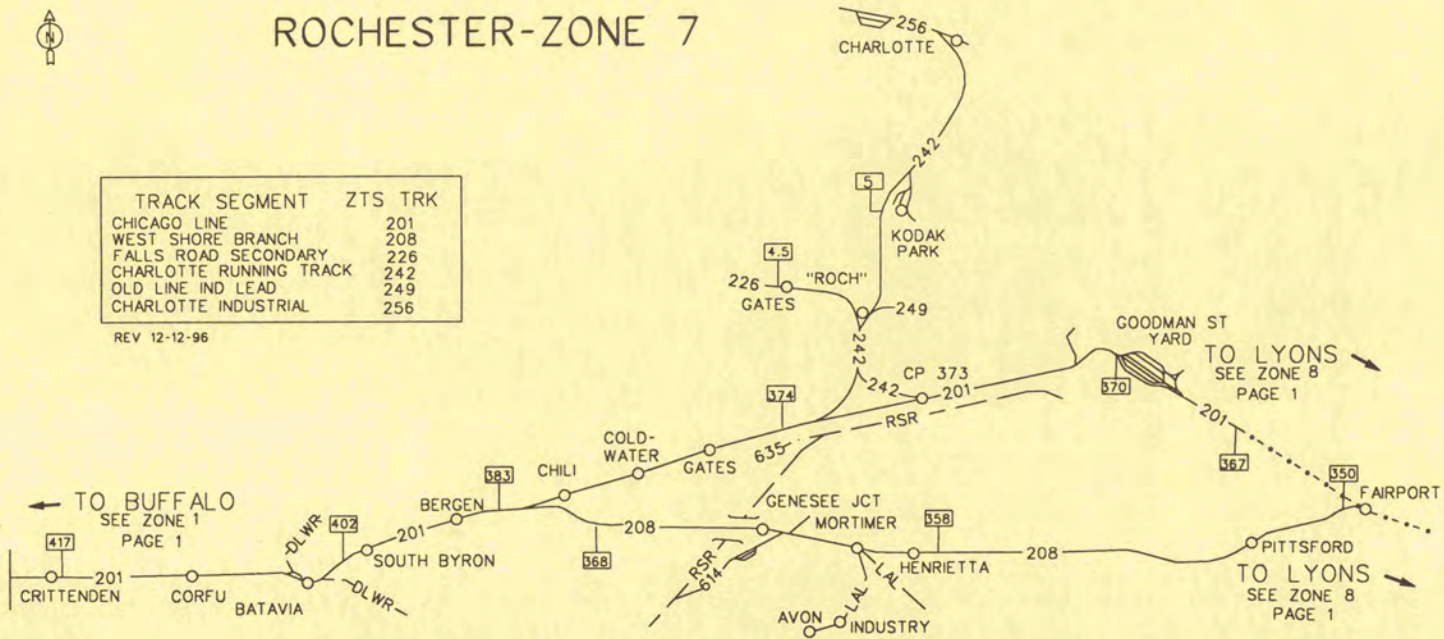



ZONE 7

Rev 12/12/96

PAGE 1

7 201 00 00 Chicago - Line - Tk.#1  
7 202 00 00 Chicago - Line - Tk.#2  
7 704 97 97 Former - (Corfu Team Tk.)

CRITTENDEN NY

CORFU NY

BATAVIA NY



← TO BUFFALO  
SEE ZONE 1  
PAGE 1

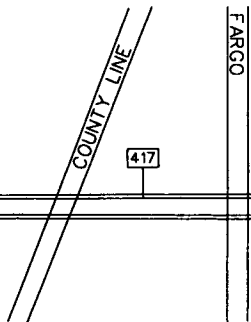

417

CP 417

415

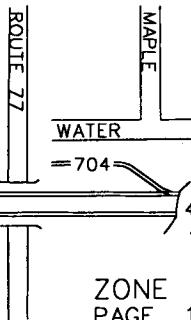

411

CP 410

TO BATAVIA YARD  
SEE ZONE 7  
PAGE 2

ZONE 7  
PAGE 1  
RDBR 30-4800

DIVISION ALBANY  
REV 12-01-96

A  
A

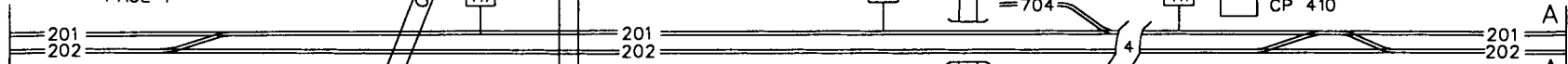

07 201 00 00 Chicago - Line - Tk.#1  
07 202 00 00 Chicago - Line - Tk.#2  
07 209 00 00 Batavia - N.Y.Sdg.  
07 210 00 00 North - Controlled - Siding  
07 544 00 00 Eng. Tk.#10  
07 605 00 00 (DLWR) - I/C - Batavia Yd.Tk.  
07 606 00 00 (DLWR) - I/C - Batavia Yd.Tk.  
07 607 00 00 (DLWR) - I/C - Batavia Yd.Tk.  
07 706 99 99 Agway Feed - Tk.#1  
07 707 01 01 Agway Feed - Tk.#2  
07 708 01 02 Agway - Feed

# BATAVIA NY

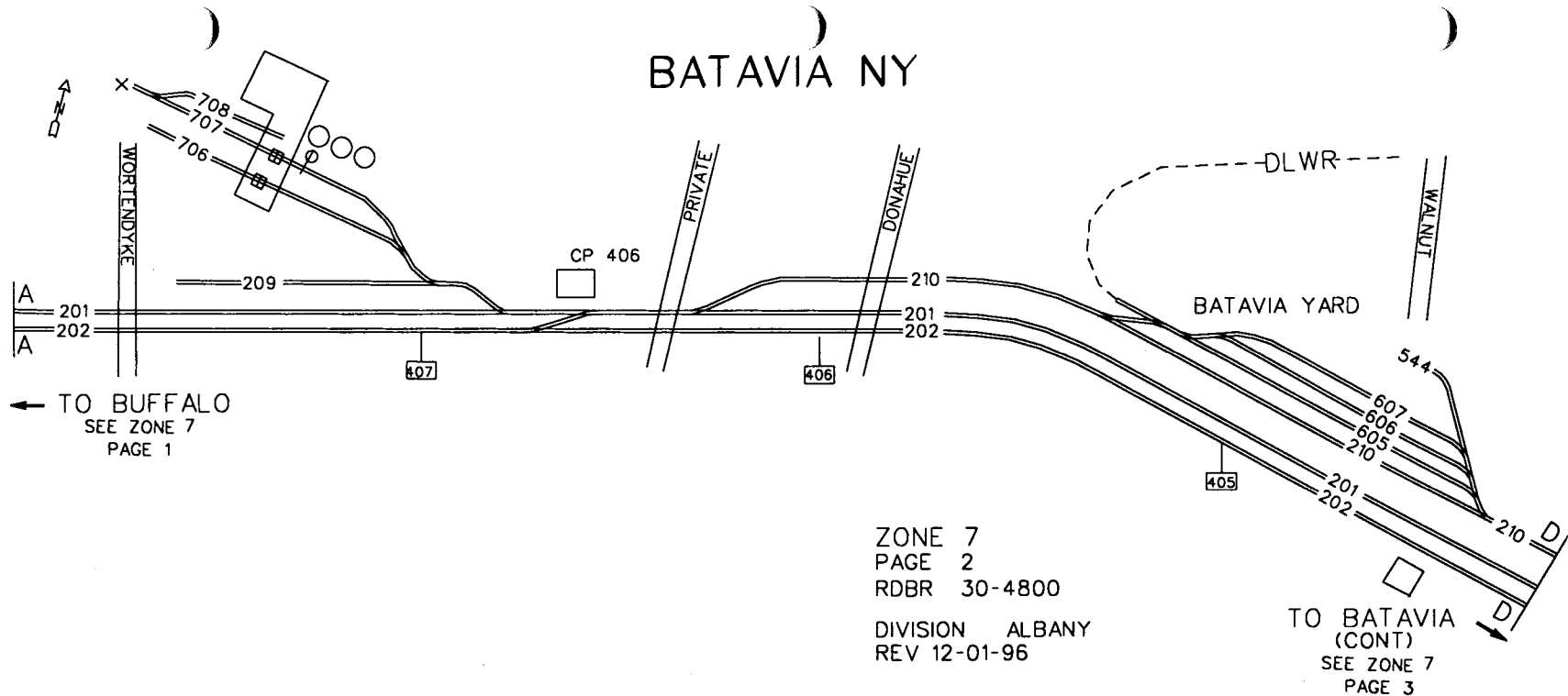

← TO BUFFALO  
SEE ZONE 7  
PAGE 1

ZONE 7  
PAGE 2  
RDBR 30-4800  
DIVISION ALBANY  
REV 12-01-96

TO BATAVIA  
(CONT)  
SEE ZONE 7  
PAGE 3

ZONE 7

Rev 12/12/96

PAGE 3

7 201 00 00 Chicago - Line - Tk.#1  
7 202 00 00 Chicago - Line - Tk.#2  
7 210 00 00 North - Controlled - Siding  
7 608 00 00 (DLWR) - Connection - Tk.

# BATAVIA NY

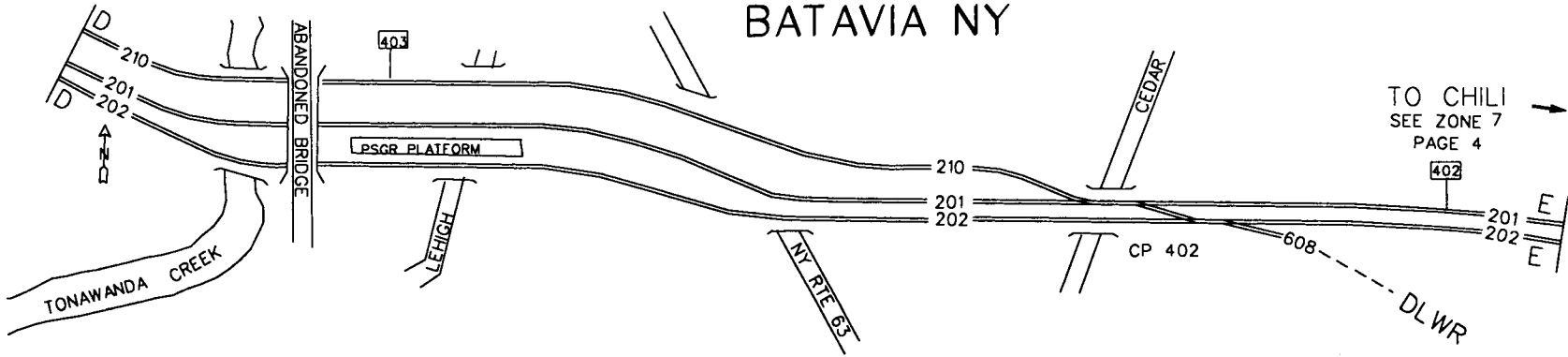

TO CHILI  
SEE ZONE 7  
PAGE 4

402

E  
E

TO BATAVIA YARD  
SEE ZONE 7  
PAGE 2

ZONE 7  
PAGE 3  
RDBR 30-4800

DIVISION ALBANY  
REV 12-01-96

ZONE 7

Rev 12/26/96

PAGE 4

|   |     |    |    |                        |
|---|-----|----|----|------------------------|
| 7 | 201 | 00 | 00 | Chicago - Line - Tk.#1 |
| 7 | 202 | 00 | 00 | Chicago - Line - Tk.#2 |
| 7 | 731 | 97 | 97 | South Byron Team Track |
| 7 | 731 | 97 | 97 | AG Network             |
| 7 | 731 | 97 | 97 | Crocker Farm Service   |
| 7 | 731 | 97 | 97 | Commodity Credit       |

SOUTH BYRON NY

BERGEN NY

TO CHILI  
SEE ZONE 7  
PAGE 5

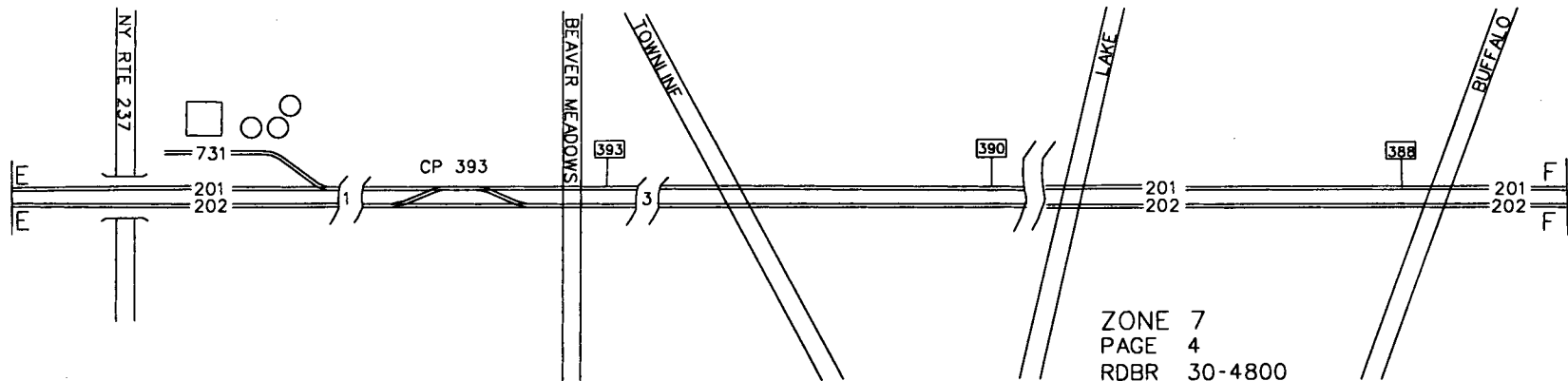

← TO BATAVIA  
SEE ZONE 7  
PAGE 3

ZONE 7  
PAGE 4  
RDBR 30-4800

DIVISION ALBANY  
REV 04-04-94



ZONE 7

Rev 12/26/96

PAGE 5

7 201 00 00 Chicago - Line - Tk.#1  
7 202 00 00 Chicago - Line - Tk.#2  
7 208 00 00 West Shore - Branch  
7 225 00 00 Rochester Ind.  
7 234 00 00 North - Controlled - Siding  
7 611 00 00 Genesee - Jct. Yd. Tk.#1  
7 612 00 00 Genesee - Jct. Yd. Tk.#2  
7 613 00 00 Genesee - Jct. Yd. Tk.#3  
7 614 00 00 (RSR) - Connection - Tk.  
7 615 00 00 (RSR) - Connection - Tk.  
7 618 00 00 (LAL) - Connection - Tk.  
7 732 01 01 Suburban Propane Gas  
7 734 01 01 Eighty Four Lumber  
7 734 01 01 Lyell Metal



CHILI NY

CHILICENTER NY

GENESEE JCT NY

TO ROCHESTER  
SEE ZONE 7  
PAGE 9

TO FAIRPORT  
SEE ZONE 7  
PAGE 6

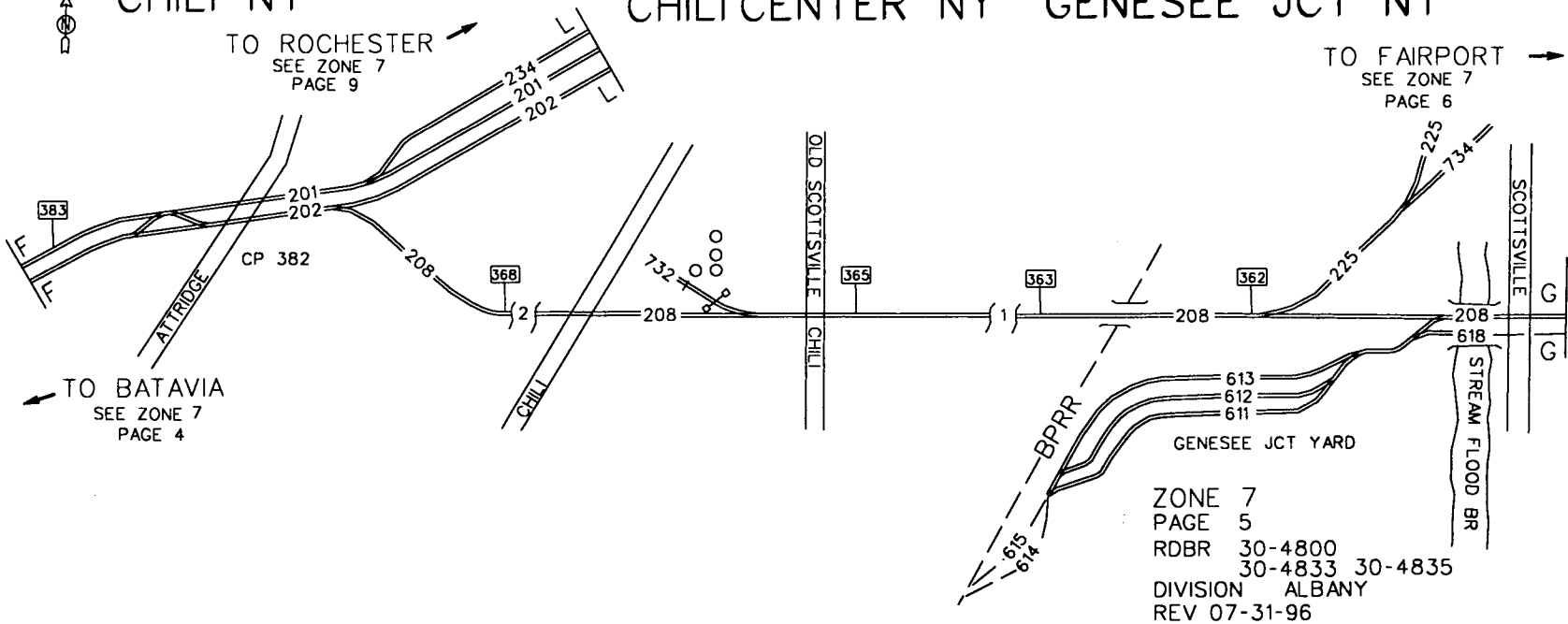

TO BATAVIA  
SEE ZONE 7  
PAGE 4

GENESEE JCT YARD

ZONE 7  
PAGE 5

RDBR 30-4800  
30-4833 30-4835

DIVISION ALBANY  
REV 07-31-96

ZONE 7 Rev 12/12/96

PAGE 6

7 208 00 00 West Shore - Branch



GENESEE JCT NY

MORTIMER NY

TO FAIRPORT  
SEE ZONE 7  
PAGE 7

360

LAL

RED CREEK

CREEK

LAL

LAL

LAL

LAL

RIVER

LEAST RIVER

BRIGHTON HENRIETTA TOWNLINE

ZONE 7  
PAGE 6  
RDBR 30-4833  
30-4835  
DIVISION ALBANY  
REV 04-12-96

TO CHILI  
SEE ZONE 7  
PAGE 5

G  
208  
LAL  
G

208 J  
J

208

208  
LAL

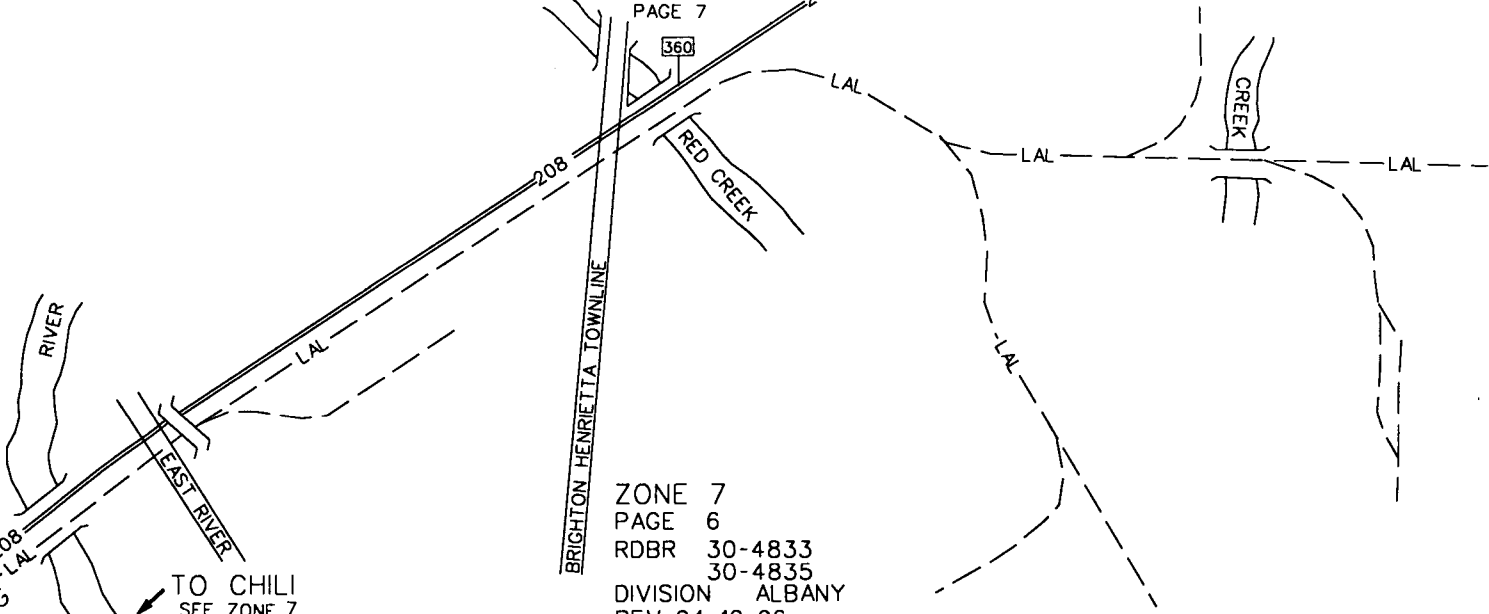
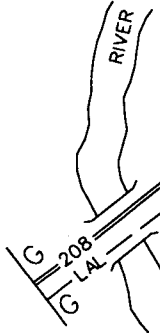

ZONE 7

Rev 12/12/96

PAGE 7

|   |     |    |    |                              |
|---|-----|----|----|------------------------------|
| 7 | 208 | 00 | 00 | West Shore - Branch          |
| 7 | 231 | 00 | 00 | Ind. Lead - Tk.              |
| 7 | 232 | 00 | 00 | Ind. Lead - Tk.              |
| 7 | 770 | 97 | 97 | ISAM Mitchell Co Inc.        |
| 7 | 770 | 97 | 97 | Henrietta - (Team Tk.)       |
| 7 | 771 | 99 | 99 | Rochester Gas & Elec.        |
| 7 | 772 | 99 | 99 | Rochester Gas & Elec.        |
| 7 | 773 | 01 | 04 | Vacant                       |
| 7 | 774 | 01 | 16 | Genesee Valley Regional Mkt. |
| 7 | 776 | 99 | 99 | Vacant                       |
| 7 | 777 | 01 | 06 | Vacant                       |

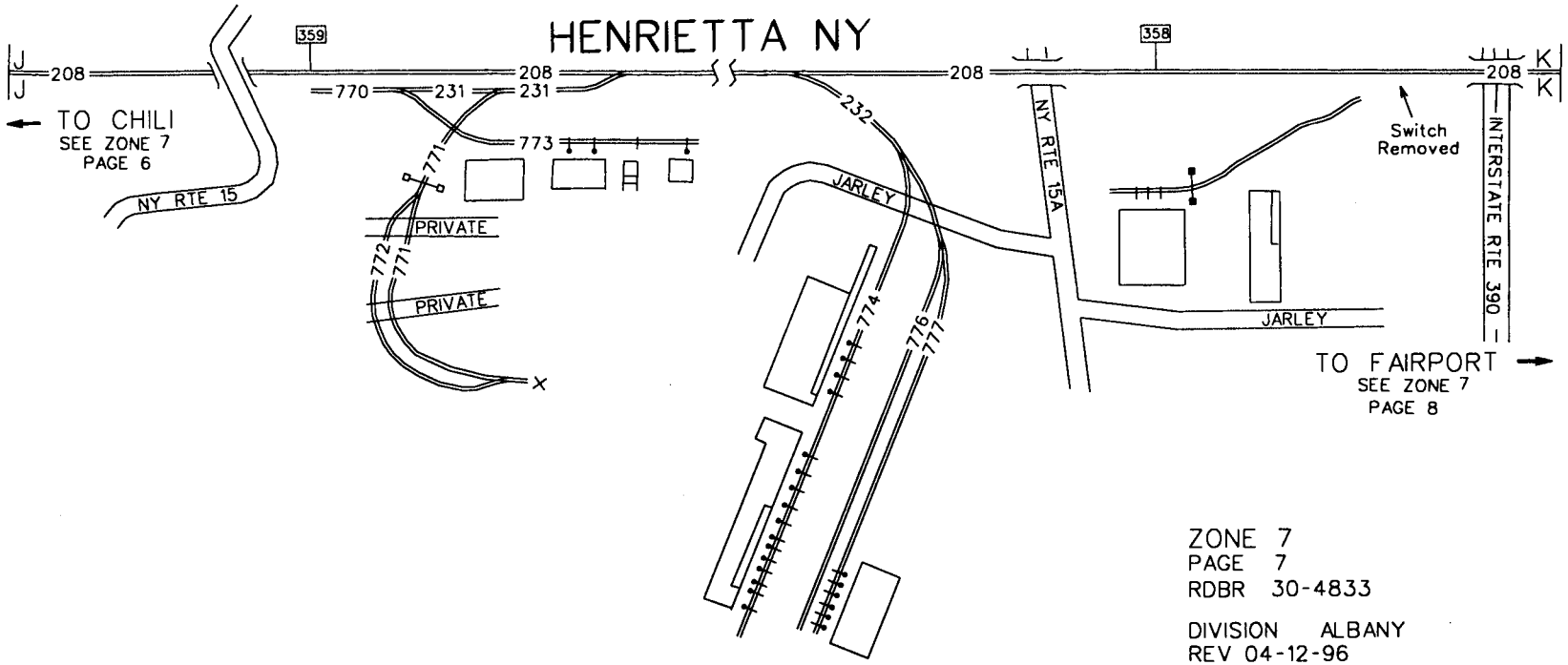

# HENRIETTA NY

ZONE 7  
 PAGE 7  
 RDBR 30-4833

DIVISION ALBANY  
 REV 04-12-96

ZONE 7

Rev 12/12/96

PAGE 8

- 7 208 00 00 West Shore - Branch
- 7 782 01 03 Wright - Wisner
- 7 787 01 04 Monoco Oil
- 7 788 01 08 Monoco Oil



HENRIETTA NY

PITTSFORD NY

FAIRPORT NY

BRIGHTON-HENRIETTA TOWNLINE

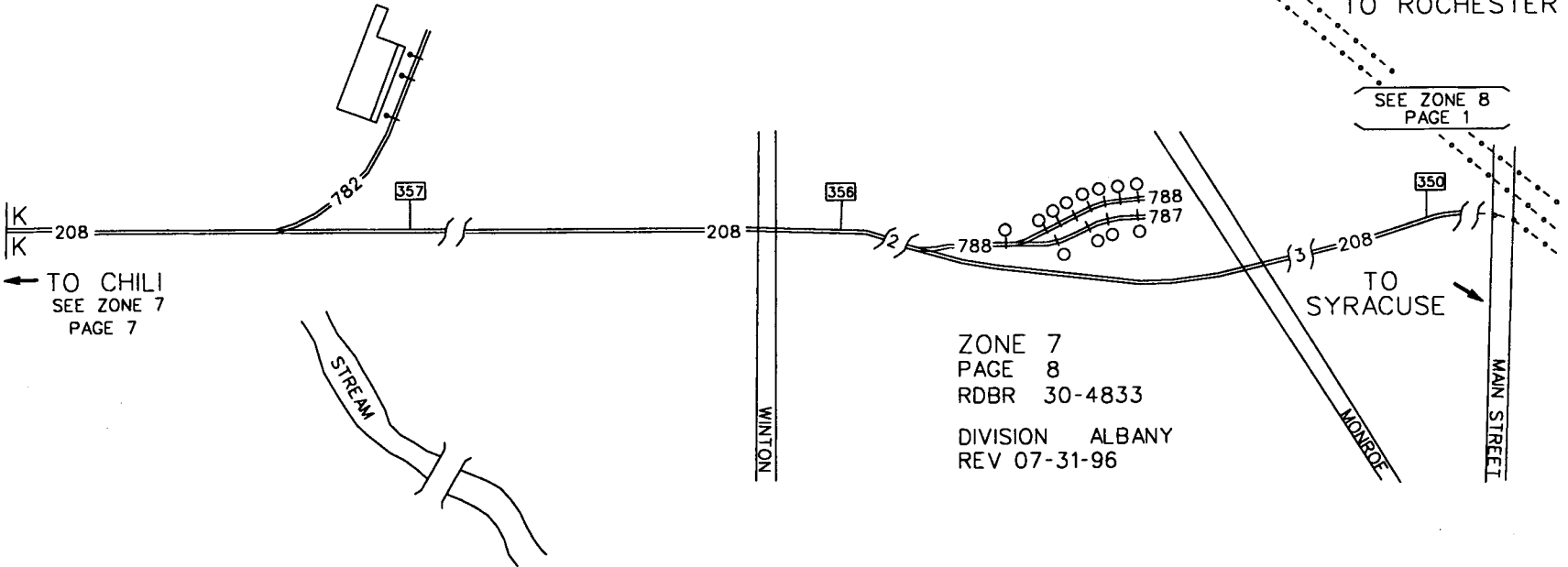

ZONE 7  
 PAGE 8  
 RDBR 30-4833  
 DIVISION ALBANY  
 REV 07-31-96



ZONE 7

Rev 12/12/96

PAGE 9

7 201 00 00 Chicago - Line - Tk.#1  
7 202 00 00 Chicago - Line - Tk.#2  
7 234 00 00 North - Controlled - Siding  
7 235 00 00 Runaround



CHILINY

COLDWATER NY

CHERRY WAY

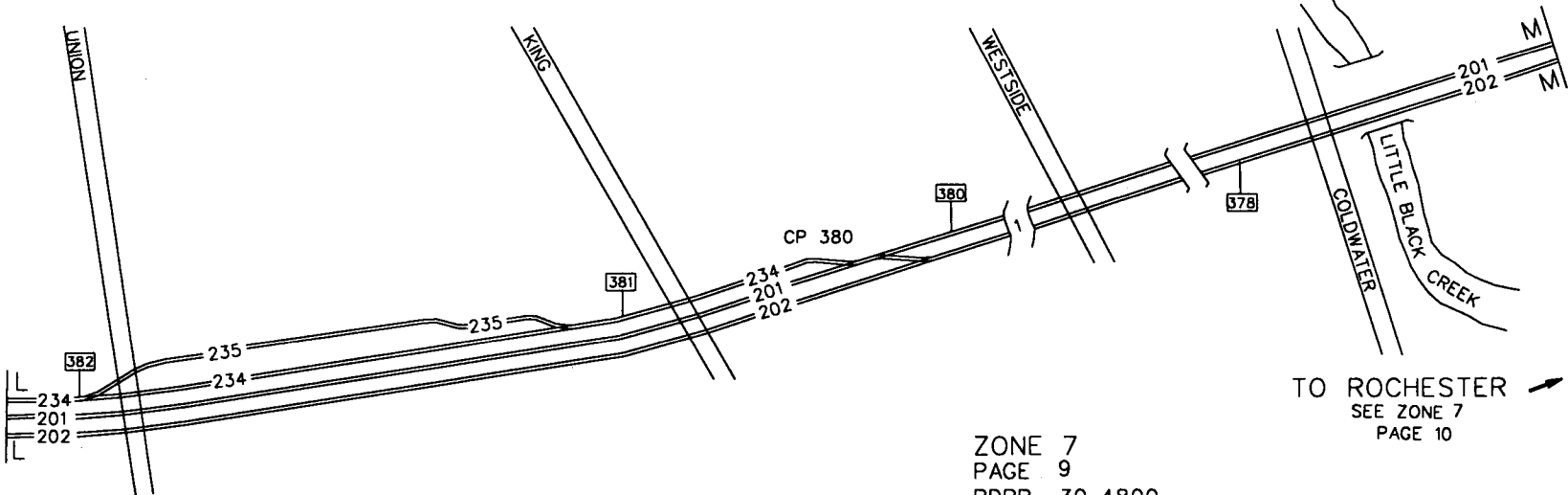

← TO BATAVIA  
SEE ZONE 7  
PAGE 5

TO ROCHESTER →  
SEE ZONE 7  
PAGE 10

ZONE 7  
PAGE 9  
RDBR 30-4800  
DIVISION ALBANY  
REV 12-06-96

ZONE 7

Rev 12/12/96

PAGE 10

- 7 201 00 00 Chicago - Line - Tk.#1
- 7 202 00 00 Chicago - Line - Tk.#2
- 7 236 00 00 Pixley - Siding
- 7 798 01 05 Rochester Stg.
- 7 799 01 05 Rochester Stg.
- 7 801 99 99 Weskesser Brick
- 7 803 01 03 Statewide Refrigerated Service

# GATES NY

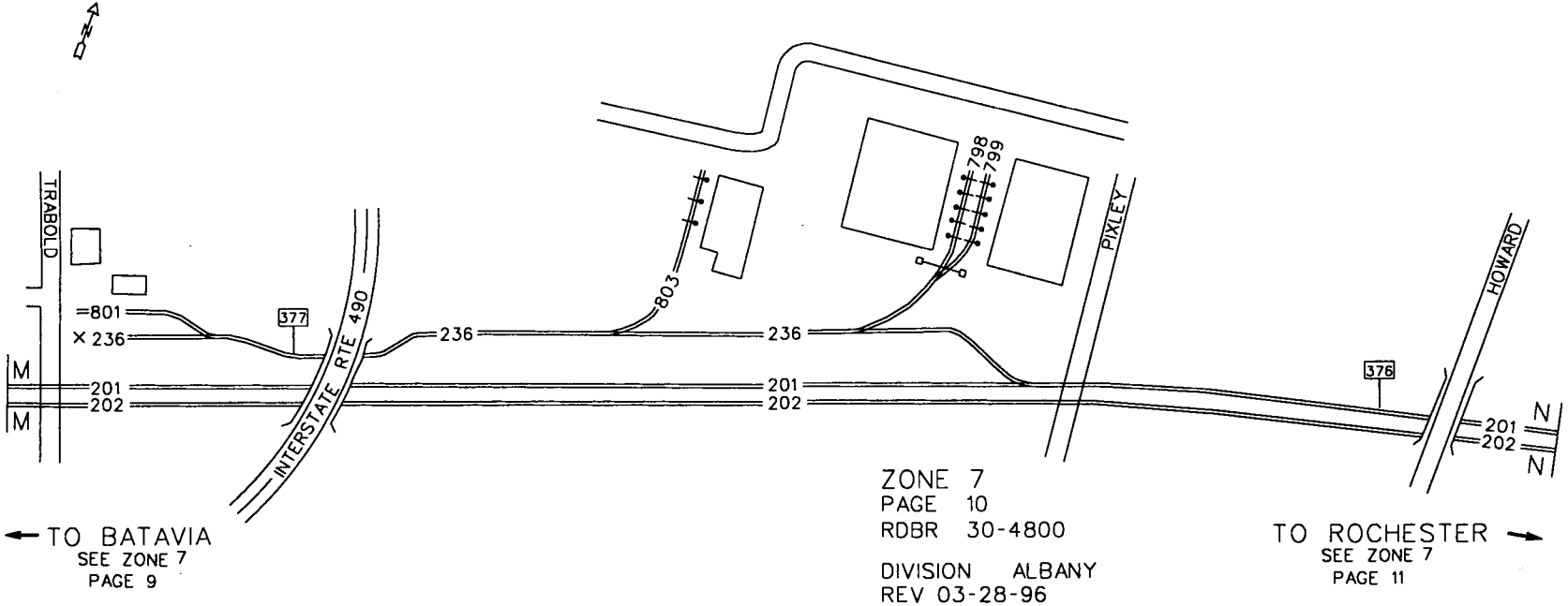

← TO BATAVIA  
SEE ZONE 7  
PAGE 9

ZONE 7  
PAGE 10  
RDBR 30-4800  
DIVISION ALBANY  
REV 03-28-96

TO ROCHESTER →  
SEE ZONE 7  
PAGE 11

ZONE 7

Rev 12/12/96

PAGE 11

|   |     |    |    |                        |
|---|-----|----|----|------------------------|
| 7 | 201 | 00 | 00 | Chicago - Line - Tk.#1 |
| 7 | 202 | 00 | 00 | Chicago - Line - Tk.#2 |
| 7 | 236 | 00 | 00 | Pixley - Siding East   |
| 7 | 238 | 00 | 00 | Long - Branch - Tk.    |
| 7 | 635 | 00 | 00 | (RSR) - I/C - Tk.      |
| 7 | 636 | 00 | 00 | (RSR) - I/C - Tk.      |
| 7 | 808 | 01 | 01 | Pennant Products       |

# ROCHESTER NY

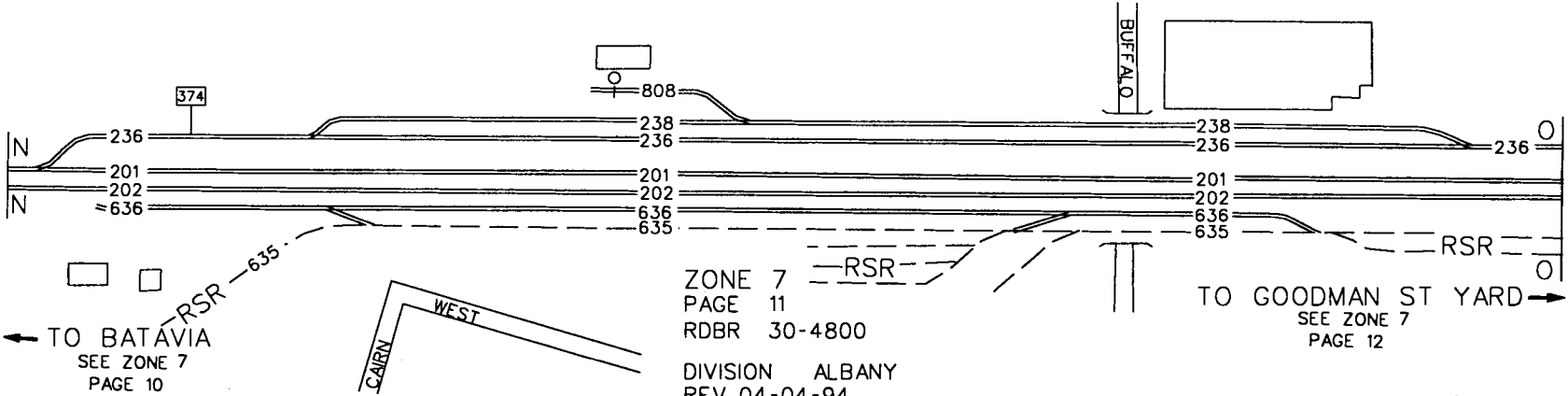

ZONE 7  
PAGE 11  
RDBR 30-4800

DIVISION ALBANY  
REV 04-04-94

TO GOODMAN ST YARD  
SEE ZONE 7  
PAGE 12

ZONE 7

Rev 12/26/96

PAGE 12

|   |     |    |    |                           |
|---|-----|----|----|---------------------------|
| 7 | 201 | 00 | 00 | Chicago - Line - Tk.#1    |
| 7 | 202 | 00 | 00 | Chicago - Line - Tk.#2    |
| 7 | 203 | 00 | 00 | Chicago - Line - Tk.#3    |
| 7 | 226 | 00 | 00 | Falls Road - Industrial   |
| 7 | 236 | 00 | 00 | Pixley - Siding - East    |
| 7 | 240 | 00 | 00 | Buffalo - Wye - Tk.       |
| 7 | 242 | 00 | 00 | Charlotte - Running - Tk. |
| 7 | 249 | 00 | 00 | Otis Yard Lead            |

# ROCHESTER NY

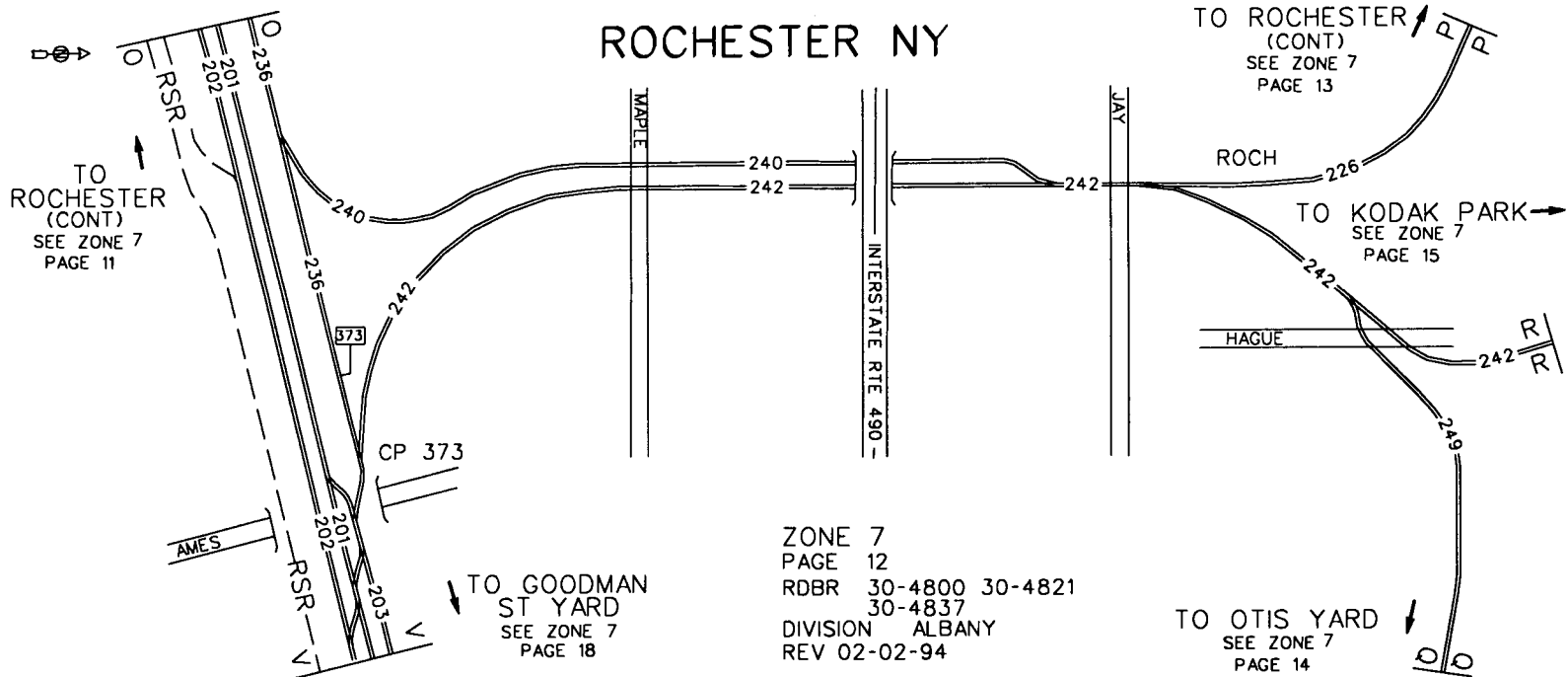

ZONE 7  
PAGE 12  
RDBR 30-4800 30-4821  
30-4837  
DIVISION ALBANY  
REV 02-02-94

TO OTIS YARD  
SEE ZONE 7  
PAGE 14

TO GOODMAN  
ST YARD  
SEE ZONE 7  
PAGE 18

TO ROCHESTER  
(CONT)  
SEE ZONE 7  
PAGE 13

TO ROCHESTER  
(CONT)  
SEE ZONE 7  
PAGE 11

TO KODAK PARK  
SEE ZONE 7  
PAGE 15



ZONE 7

Rev 12/26/96

PAGE 13

|   |     |    |    |                           |
|---|-----|----|----|---------------------------|
| 7 | 226 | 00 | 00 | Falls Road - Industrial   |
| 7 | 243 | 00 | 00 | Siding                    |
| 7 | 246 | 00 | 00 | Ind. Lead - Tk.           |
| 7 | 247 | 00 | 00 | Runaround                 |
| 7 | 550 | 00 | 00 | Flexi Flo - (Company Use) |
| 7 | 811 | 01 | 02 | Cantisano Food            |
| 7 | 812 | 99 | 99 | Genesee Scrap             |
| 7 | 813 | 99 | 99 | Genesee Scrap             |
| 7 | 816 | 01 | 05 | Ragu Foods - Old Tk.      |
| 7 | 817 | 99 | 99 | Ragu Foods - New Tk.      |
| 7 | 818 | 01 | 01 | Atlantic Refining         |
| 7 | 821 | 99 | 99 | RRT Recycle America       |
| 7 | 822 | 99 | 99 | Rochester Products        |
| 7 | 823 | 99 | 99 | Rochester Products        |
| 7 | 824 | 99 | 99 | Rochester Products        |
| 7 | 826 | 01 | 02 | Chemical Sales            |



ZONE 7

Rev 12/26/96

PAGE 14

- 7 249 00 00 Otis Yard Lead
- 7 830 01 03 Rendall Paper
- 7 834 99 99 Kleen Brite Chemical
- 7 835 99 99 Kleen Brite Chemical

# ROCHESTER NY

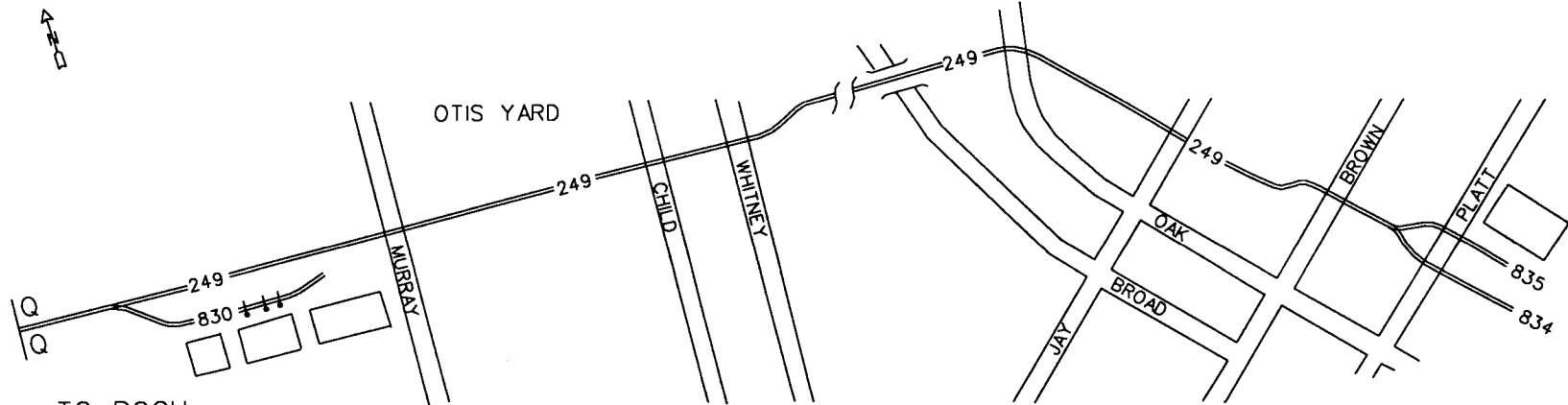

TO ROCH  
SEE ZONE 7  
PAGE 12

ZONE 7  
PAGE 14  
RDBR 30-4837

DIVISION ALBANY  
REV 12-06-96

ZONE 7

Rev 12/12/96

PAGE 15

|   |     |    |    |                           |
|---|-----|----|----|---------------------------|
| 7 | 242 | 00 | 00 | Charlotte - Running - Tk. |
| 7 | 254 | 00 | 00 | Short - Runaround - Tk.   |
| 7 | 255 | 00 | 00 | Long - Runaround - Tk.    |
| 7 | 841 | 99 | 99 | Marshall Box              |
| 7 | 843 | 99 | 99 | Eastman Kodak - Scale Tk. |
| 7 | 844 | 99 | 99 | Eastman Kodak - Main Tk.  |
| 7 | 845 | 99 | 99 | Eastman Kodak - Tk.#5     |
| 7 | 846 | 99 | 99 | Eastman Kodak - Tk.#6     |
| 7 | 847 | 99 | 99 | Eastman Kodak - Tk.#7     |
| 7 | 848 | 99 | 99 | Eastman Kodak - Tk.#8     |
| 7 | 849 | 99 | 99 | Eastman Kodak - Tk.#9     |
| 7 | 852 | 99 | 99 | Eastman Kodak - Tk.#2     |
| 7 | 853 | 99 | 99 | Eastman Kodak - Tk.#3     |
| 7 | 854 | 99 | 99 | Eastman Kodak - Tk.#4     |

# ROCHESTER NY

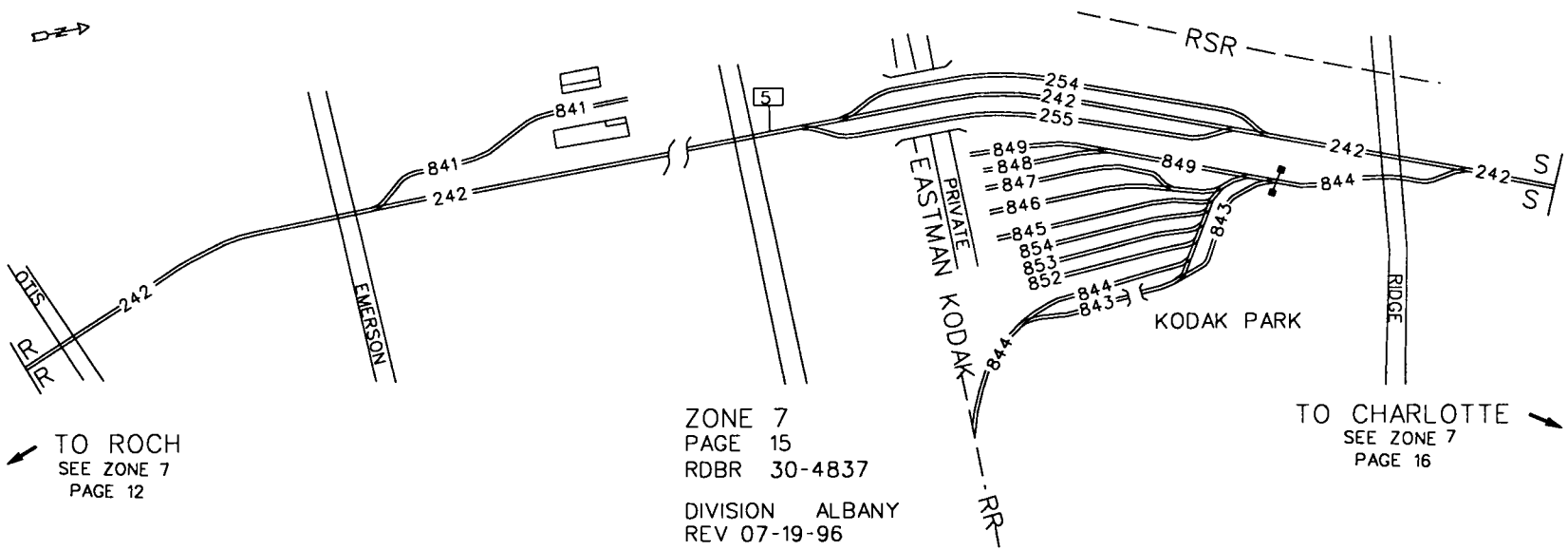

TO ROCH  
SEE ZONE 7  
PAGE 12

ZONE 7  
PAGE 15  
RDBR 30-4837

DIVISION ALBANY  
REV 07-19-96

TO CHARLOTTE  
SEE ZONE 7  
PAGE 16

ZONE 7

Rev 12/26/96

PAGE 16

7 242 00 00 Charlotte - Running - Tk.  
7 256 00 00 Charlotte - Ind. Tk.  
7 257 00 00 Runaround  
7 258 00 00 Ontario - Ind. Tk.  
7 551 00 00 Old Rail Station - Tk.  
7 855 01 04 Weyerhauser - Old Tk.

CHAR' OTTE NY

WINDSOR BEACH N.Y.



TO CHARLOTTE YARD  
SEE ZONE 7  
PAGE 17

TO ROCH  
SEE ZONE 7  
PAGE 15

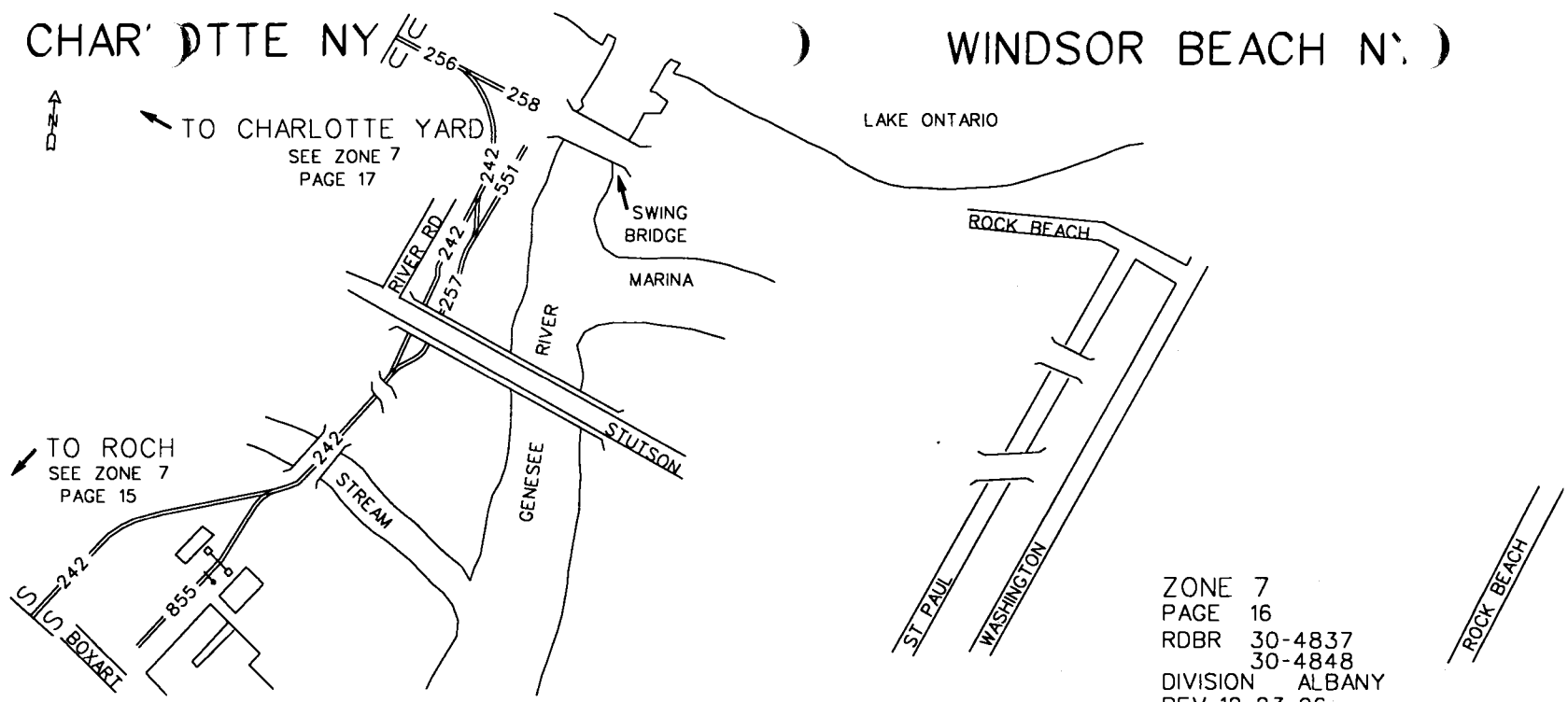

LAKE ONTARIO

SWING  
BRIDGE

MARINA

ROCK BEACH

GENESEE  
RIVER

STUTSON

STREAM

RIVER RD

ST PAUL

WASHINGTON

ROCK BEACH

ZONE 7  
PAGE 16  
RDBR 30-4837  
30-4848  
DIVISION ALBANY  
REV 12-23-96



ZONE 7

Rev 12/26/96

PAGE 17

|   |     |    |    |                                      |
|---|-----|----|----|--------------------------------------|
| 7 | 256 | 00 | 00 | Charlotte - Ind. Tk.                 |
| 7 | 265 | 00 | 00 | Ind. Lead - Tk.                      |
| 7 | 645 | 00 | 00 | Charlotte - Yd. Tk.#5                |
| 7 | 646 | 00 | 00 | Charlotte - Yd. Tk.#6                |
| 7 | 647 | 00 | 00 | Charlotte - Yd. Tk.#7                |
| 7 | 881 | 99 | 99 | Roch. Gas & Elec.- Russell New Tk.#1 |
| 7 | 882 | 99 | 99 | Roch. Gas & Elec.- Russell New Tk.#2 |
| 7 | 891 | 99 | 99 | Rochester Gas & Elec.- Russell Tk.#1 |
| 7 | 892 | 99 | 99 | Rochester Gas & Elec - Russell Tk.#2 |
| 7 | 893 | 99 | 99 | Rochester Gas & Elec - Russell Tk.#3 |
| 7 | 894 | 99 | 99 | Rochester Gas & Elec - Russell Tk.#4 |
| 7 | 895 | 99 | 99 | Rochester Gas & Elec - Russell Tk.#5 |
| 7 | 896 | 99 | 99 | Rochester Gas & Elec - Russell Tk.#6 |
| 7 | 897 | 01 | 02 | Rochester Gas & Elec - Russell Tk.#7 |

# CHARLOTTE NY

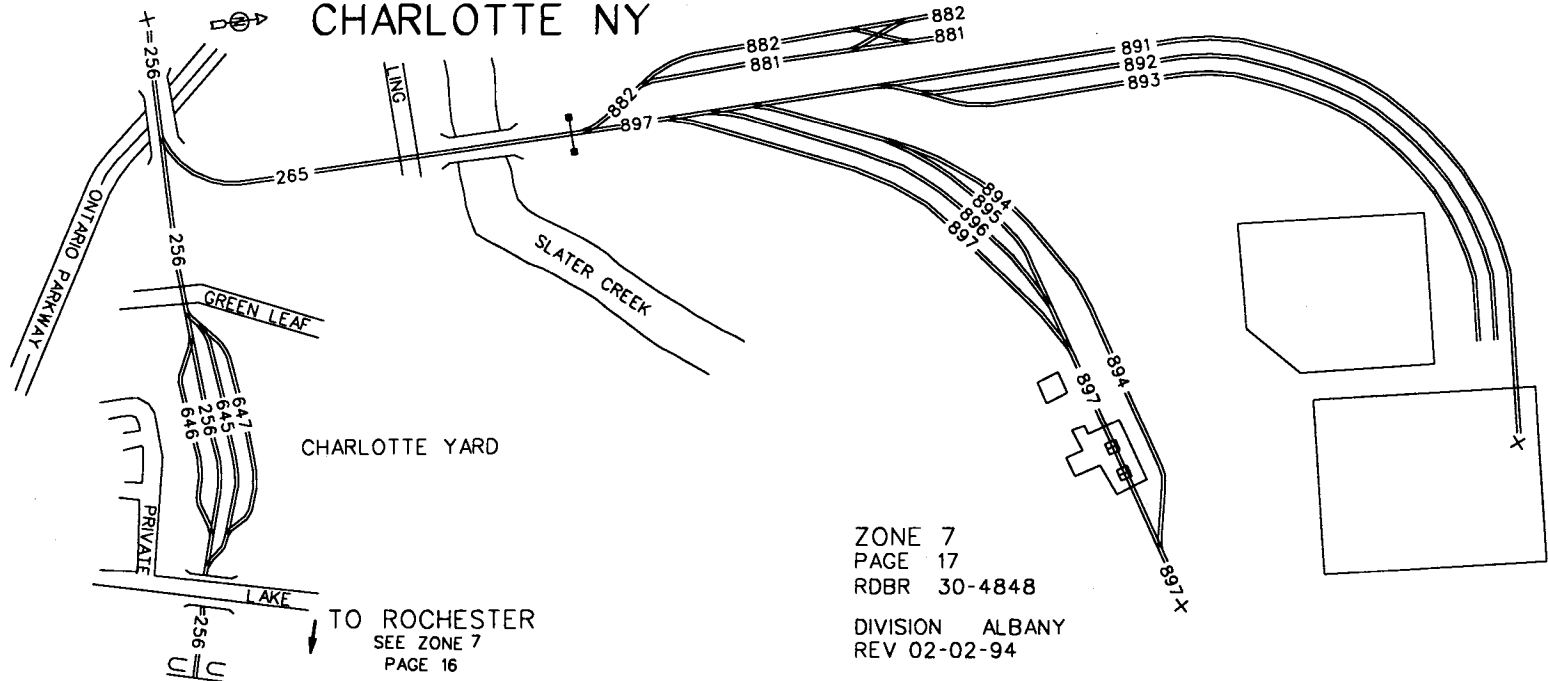

ZONE 7  
PAGE 17  
RDBR 30-4848

DIVISION ALBANY  
REV 02-02-94

ZONE 7

Rev 12/26/96

PAGE 18

|   |     |    |    |                             |
|---|-----|----|----|-----------------------------|
| 7 | 201 | 00 | 00 | Chicago - Line - Tk.#1      |
| 7 | 202 | 00 | 00 | Chicago - Line - Tk.#2      |
| 7 | 203 | 00 | 00 | Chicago - Line - Tk.#3      |
| 7 | 204 | 00 | 00 | Chicago - Line - Tk.#4      |
| 7 | 268 | 00 | 00 | Former - (Chicago Line #5)  |
| 7 | 901 | 01 | 04 | Genesee Brewing - (GFR) Tk. |
| 7 | 902 | 01 | 02 | Genesee Brewing - (GFR) Tk. |
| 7 | 903 | 01 | 01 | Genesee Brewing - (GFR) Tk. |
| 7 | 908 | 99 | 99 | Vacant                      |
| 7 | 909 | 01 | 02 | Liquitane                   |
| 7 | 910 | 99 | 99 | Otis Lumber                 |

# ROCHESTER NY

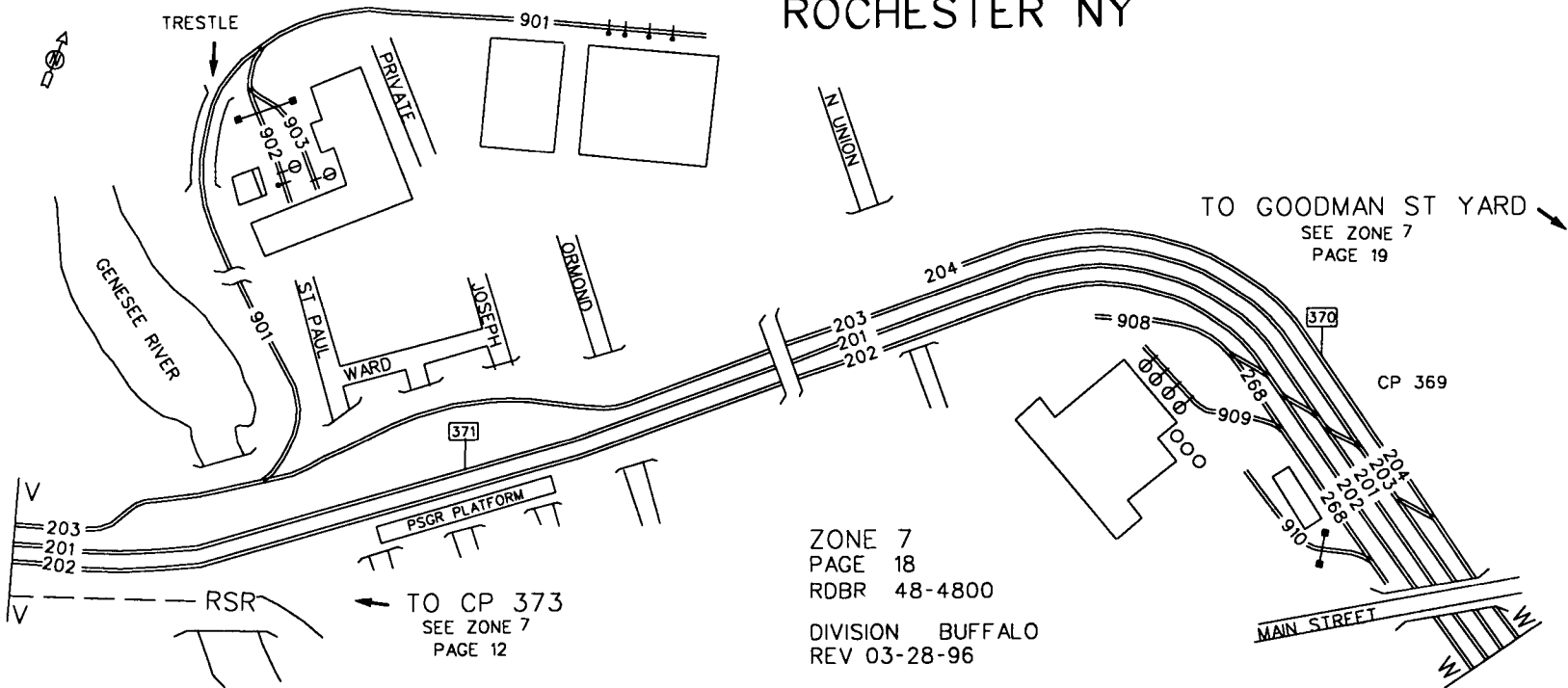

ZONE 7  
PAGE 18  
RDBR 48-4800

DIVISION BUFFALO  
REV 03-28-96

- 7 001 00 00 Rochester - Class. Yd. Tk.#1
- 7 002 00 00 Rochester - Class. Yd. Tk.#2
- 7 003 00 00 Rochester - Class. Yd. Tk.#3
- 7 004 00 00 Rochester - Class. Yd. Tk.#4
- 7 005 00 00 Rochester - Class. Yd. Tk.#5
- 7 006 00 00 Rochester - Class. Yd. Tk.#6
- 7 007 00 00 Rochester - Class. Yd. Tk.#7
- 7 008 00 00 Rochester - Class. Yd. Tk.#8
- 7 009 00 00 Rochester - Class. Yd. Tk.#9
- 7 010 00 00 Rochester - Class. Yd. Tk.#10
- 7 011 00 00 Rochester - Class. Yd. Tk.#11
- 7 201 00 00 Chicago - Line - Tk.#1
- 7 202 00 00 Chicago - Line - Tk.#2
- 7 203 00 00 Chicago - Line - Tk.#3
- 7 204 00 00 Chicago - Line - Tk.#4
- 7 274 00 00 Lead
- 7 301 00 00 Rochester - Rec. Yd. Tk.#1
- 7 302 00 00 Rochester - Rec. Yd. Tk.#2
- 7 303 00 00 Rochester - Rec. Yd. Tk.#3
- 7 304 00 00 Rochester - Rec. Yd. Tk.#4
- 7 305 00 00 Rochester - Rec. Yd. Tk.#5
- 7 306 00 00 Rochester - Rec. Yd. Tk.#6
- 7 501 00 00 Road Railer - Tk.#1
- 7 501 99 99 Triple Crown (Leased)
- 7 502 00 00 Road Railer - Tk.#2
- 7 502 99 99 Triple Crown (Leased)
- 7 570 00 00 M of W Track
- 7 571 00 00 M of W Track
- 7 573 00 00 West - Leg Wye - Tk.
- 7 574 00 00 East - Leg Wye - Tk.
- 7 575 00 00 South Leg Wye - Tk.
- 7 576 00 00 Eng. House - Tk.
- 7 577 00 00 Eng. House - Tk.
- 7 578 00 00 Sand Trap - Tk.
- 7 579 00 00 Stg. Tk.
- 7 580 00 00 North - Fuel - Tk.
- 7 581 00 00 South - Fuel - Tk.
- 7 582 00 00 Spur
- 7 583 00 00 Repair - Tk.
- 7 584 00 00 Chute - Tk.
- 7 585 00 00 Vacant
- 7 586 00 00 Vacant
- 7 651 00 00 Old Hole - Tk.
- 7 921 97 97 Chemreal
- 7 921 97 97 Severson Environment

ZONE 7

Rev 12/26/96

PAGE 19 (continued)

7 921 97 97 Rochester - (Team Tk).  
7 922 97 97 Rochester - (Team Tk).  
7 922 97 97 Flower City Produce  
7 922 97 97 J Kozel Son

# ROCHESTER NY

GOODMAN STREET YARD

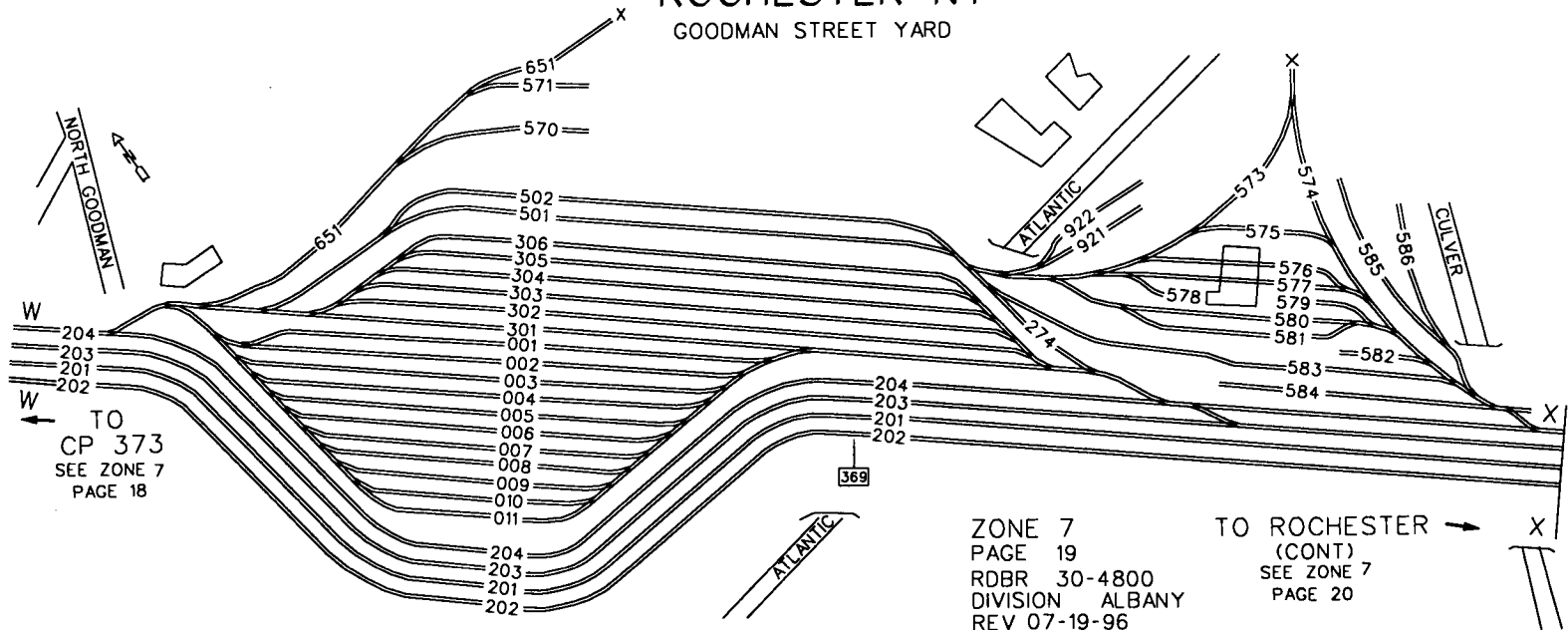

TO  
CP 373  
SEE ZONE 7  
PAGE 18

ZONE 7  
PAGE 19  
RDBR 30-4800  
DIVISION ALBANY  
REV 07-19-96

TO ROCHESTER →  
(CONT)  
SEE ZONE 7  
PAGE 20

ZONE 7

Rev 12/26/96

PAGE 20

|   |     |    |    |                        |
|---|-----|----|----|------------------------|
| 7 | 201 | 00 | 00 | Chicago - Line - Tk.#1 |
| 7 | 202 | 00 | 00 | Chicago - Line - Tk.#2 |
| 7 | 203 | 00 | 00 | Chicago - Line - Tk.#3 |
| 7 | 204 | 00 | 00 | Chicago - Line - Tk.#4 |
| 7 | 275 | 00 | 00 | Chicago - Line - Tk.#5 |
| 7 | 933 | 01 | 03 | Rochester Lumber       |



# ROCHESTER NY

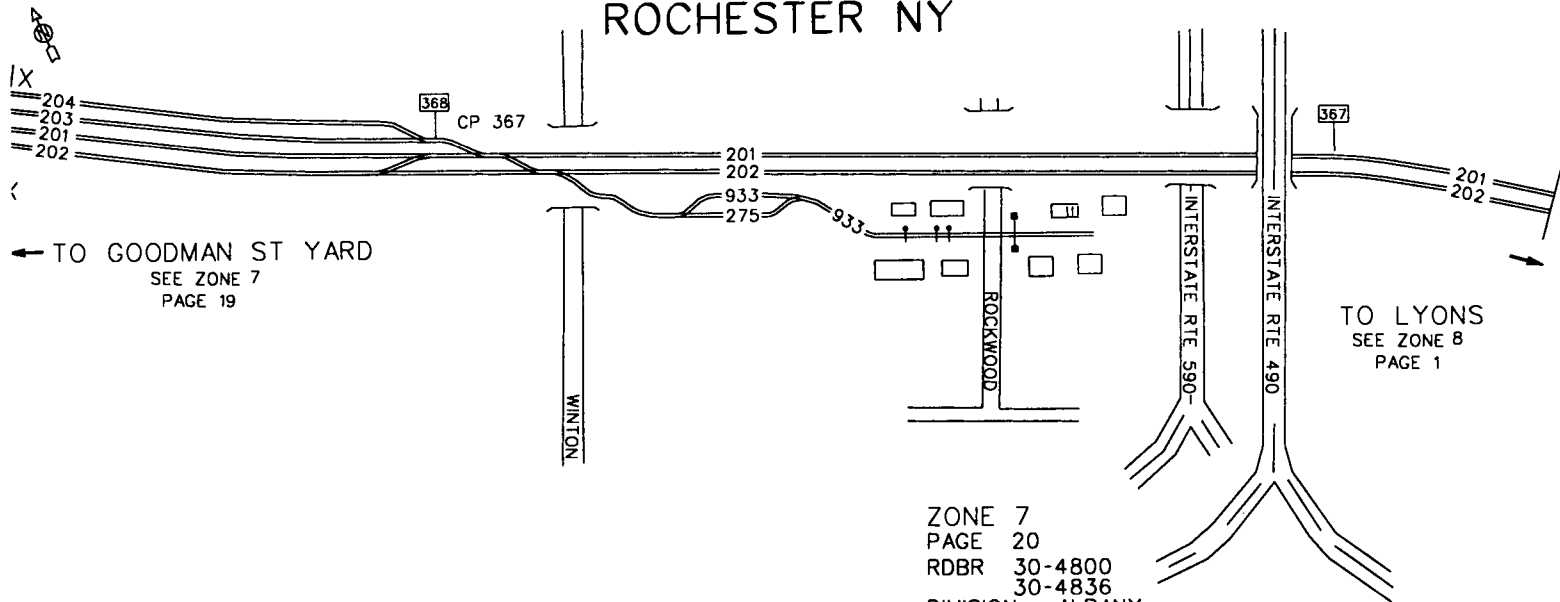

← TO GOODMAN ST YARD  
SEE ZONE 7  
PAGE 19

TO LYONS  
SEE ZONE 8  
PAGE 1

ZONE 7  
PAGE 20  
RDBR 30-4800  
30-4836  
DIVISION ALBANY  
REV 01-28-97

# LYONS ZONE 8



← TO ROCHESTER  
SEE ZONE 7  
PAGE 20

TO SYRACUSE →  
SEE ZONE 85  
PAGE 21

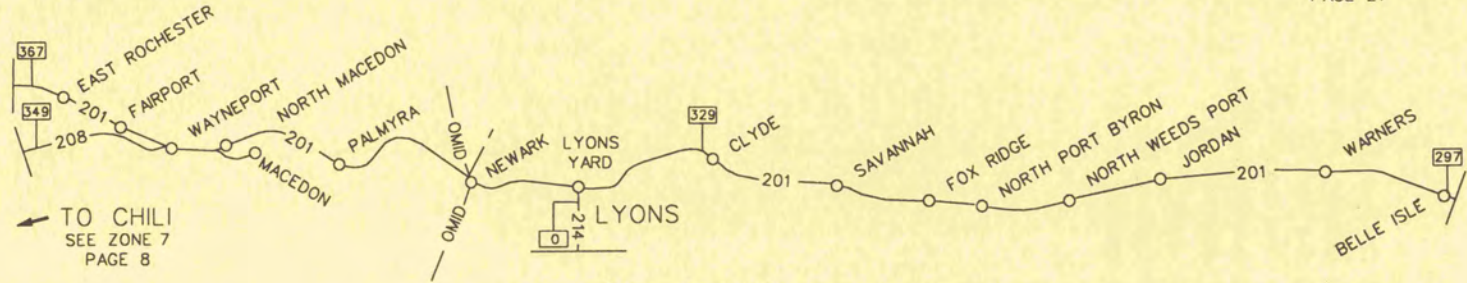

← TO CHILI  
SEE ZONE 7  
PAGE 8

↓ TO GENEVA  
SEE ZONE 9  
PAGE 1

| TRACK SEGMENT     | ZTS TRK |
|-------------------|---------|
| CHICAGO LINE      | 201     |
| WEST SHORE BRANCH | 208     |
| CORNING SECONDARY | 214     |

REV 12-12-96

ZONE 8

Rev 12/12/96

PAGE 1

|   |     |    |    |                        |
|---|-----|----|----|------------------------|
| 8 | 201 | 00 | 00 | Chicago - Line - Tk.#1 |
| 8 | 202 | 00 | 00 | Chicago - Line - Tk.#2 |
| 8 | 204 | 00 | 00 | The Dead - Tk.         |
| 8 | 208 | 00 | 00 | West Shore - Branch    |
| 8 | 706 | 01 | 02 | Guardian Purchasing    |
| 8 | 708 | 01 | 01 | Allied Plywood         |
| 8 | 709 | 01 | 03 | Vacant                 |
| 8 | 711 | 01 | 05 | Cantisano Foods        |
| 8 | 716 | 99 | 99 | Cantisano Foods        |

# EAST ROCHESTER NY

# FAIRPORT NY

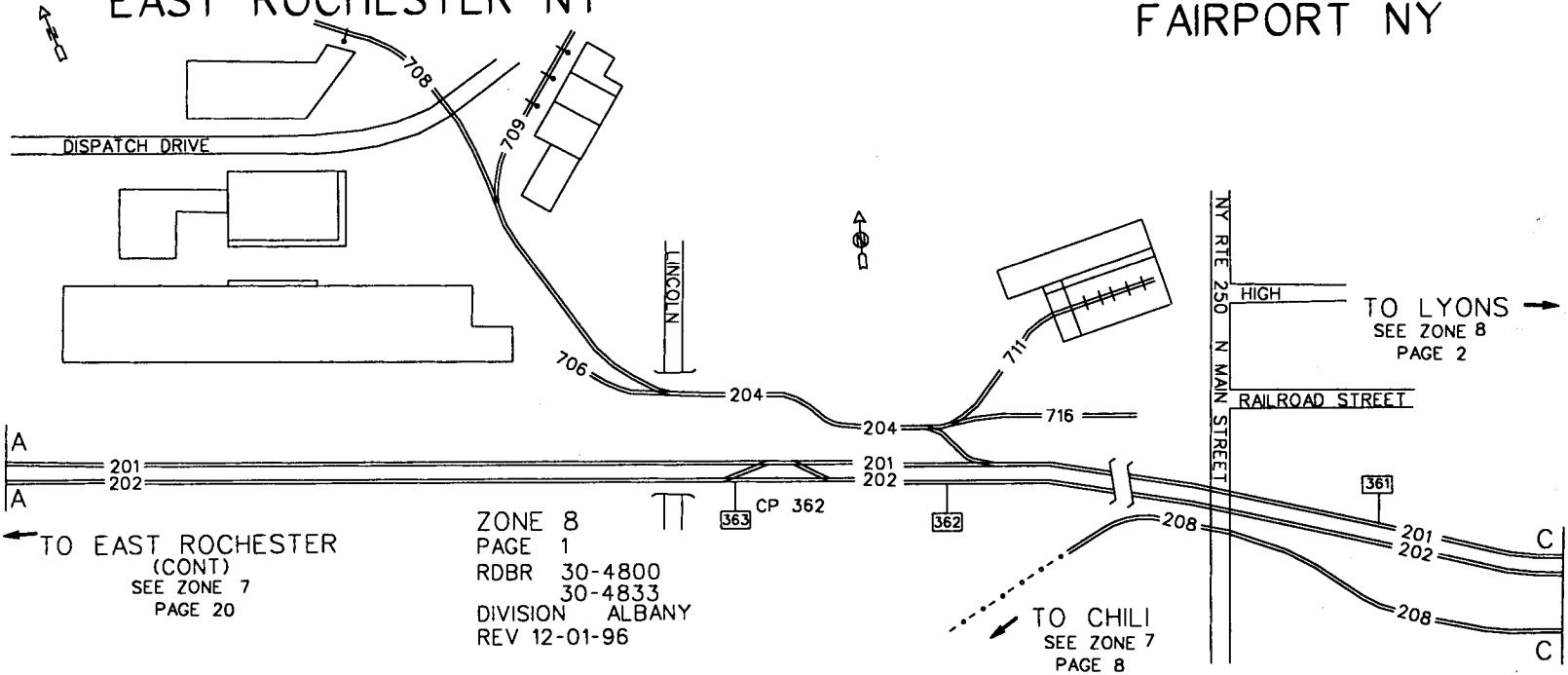

← TO EAST ROCHESTER  
(CONT)  
SEE ZONE 7  
PAGE 20

ZONE 8  
PAGE 1  
RDBR 30-4800  
30-4833  
DIVISION ALBANY  
REV 12-01-96

TO CHILI  
SEE ZONE 7  
PAGE 8

TO LYONS  
SEE ZONE 8  
PAGE 2

ZONE 08

Rev 04/01/94

PAGE 2

08 201 00 00 Chicago - Line - Tk.#1

08 202 00 00 Chicago - Line - Tk.#2

08 208 00 00 West Shore - Branch

08 224 00 00 Wayneport Siding

# WAYNEPORT NY

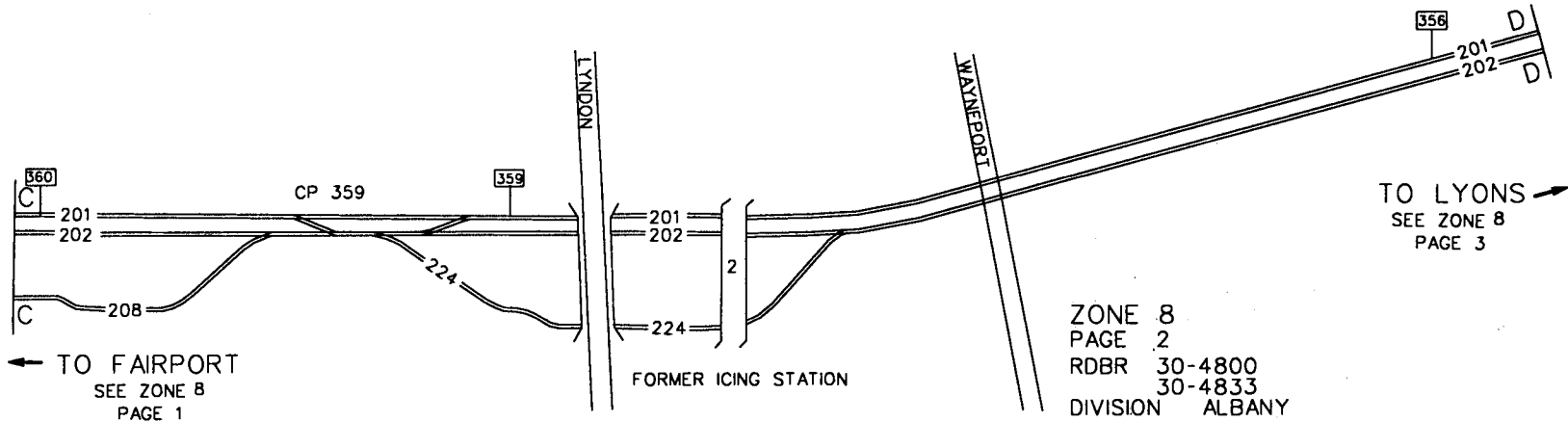

← TO FAIRPORT  
SEE ZONE 8  
PAGE 1

TO LYONS →  
SEE ZONE 8  
PAGE 3

ZONE 8  
PAGE 2  
RDBR 30-4800  
30-4833  
DIVISION ALBANY  
REV 04-04-94

ZONE 8

Rev 12/12/96

PAGE 3

|   |     |    |    |                            |
|---|-----|----|----|----------------------------|
| 8 | 201 | 00 | 00 | Chicago - Line - Tk.#1     |
| 8 | 202 | 00 | 00 | Chicago - Line - Tk.#2     |
| 8 | 219 | 00 | 00 | Mobil Chemical - Lead      |
| 8 | 222 | 00 | 00 | Lead                       |
| 8 | 720 | 01 | 05 | Mobil Chemical - Spur Tk.  |
| 8 | 721 | 01 | 13 | Mobil Chemical - North Tk. |
| 8 | 722 | 01 | 17 | Mobil Chemical - South Tk. |
| 8 | 723 | 99 | 99 | Outside - Runaround Tk.    |
| 8 | 726 | 01 | 03 | Agway - Palmyra            |
| 8 | 727 | 01 | 01 | Stanton AG Service         |
| 8 | 727 | 01 | 01 | Palmyra Builders Supply    |





ZONE 08

Rev 04/01/94

PAGE 4

08 201 00 00 Chicago - Line - Tk.#1

08 202 00 00 Chicago - Line - Tk.#2

08 227 00 00 Old Passing - Siding

08 229 00 00 Back Tk.

08 612 00 00 (OMID) - Connection - Tk.

08 613 00 00 (OMID) - I/C - Tk.



# NEWARK NY

TO LYONS  
SEE ZONE 8  
PAGE 5

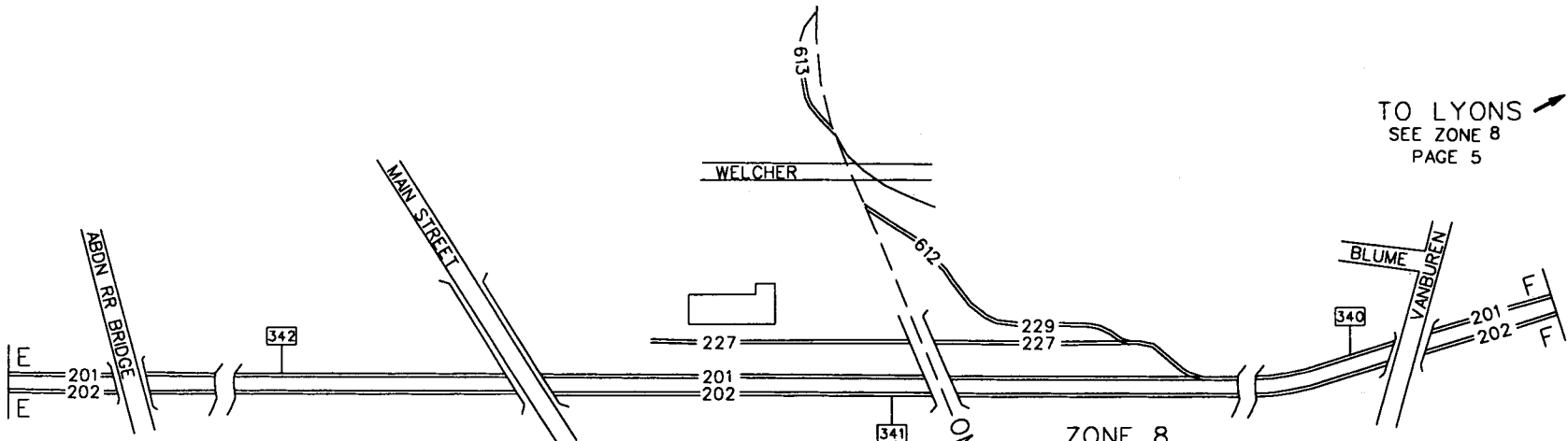

← TO WAYNEPORT  
SEE ZONE 8  
PAGE 3

ZONE 8  
 PAGE 4  
 RDBR 30-2319 30-4819  
 30-4800  
 DIVISION ALBANY  
 REV 01-28-97

|   |     |    |    |                                     |
|---|-----|----|----|-------------------------------------|
| 8 | 201 | 00 | 00 | Chicago - Line - Tk.#1              |
| 8 | 202 | 00 | 00 | Chicago - Line - Tk.#2              |
| 8 | 214 | 00 | 00 | Corning - Secondary                 |
| 8 | 215 | 00 | 00 | Corning - Running Track - South Leg |
| 8 | 232 | 00 | 00 | Lyons - Yd. Lead                    |
| 8 | 233 | 00 | 00 | Controlled - Siding                 |
| 8 | 238 | 00 | 00 | Lead - Tk.#N 80                     |
| 8 | 240 | 00 | 00 | Ind. Lead - Tk.                     |
| 8 | 546 | 00 | 00 | M of W - Camp Car Tk.               |
| 8 | 547 | 00 | 00 | M of W - Pit Tk.                    |
| 8 | 601 | 00 | 00 | Lyons - Yd. Tk.#1                   |
| 8 | 601 | 01 | 63 | Mobil Chemical (Lease 3500 Ft)      |
| 8 | 602 | 00 | 00 | Lyons - Yd. Tk.#2                   |
| 8 | 603 | 00 | 00 | Lyons - Yd. Tk.#3                   |
| 8 | 604 | 00 | 00 | Lyons - Yd. Tk.#4                   |
| 8 | 605 | 00 | 00 | Lyons - Yd. Tk.#5 - (Outside Track) |
| 8 | 607 | 00 | 00 | Lyons - Yd. Tk.#7                   |
| 8 | 608 | 00 | 00 | Lyons - Yd. Tk.#8                   |
| 8 | 609 | 00 | 00 | Lyons - Yd. Tk.#9                   |
| 8 | 615 | 00 | 00 | Lyons - Yd. Tk.#15                  |
| 8 | 731 | 97 | 97 | Brisky Supply Co.                   |
| 8 | 731 | 97 | 97 | Lyons - (Team Tk.)                  |
| 8 | 731 | 97 | 97 | AMG Resources                       |
| 8 | 731 | 97 | 97 | Oberdorfer Foundries                |
| 8 | 731 | 97 | 97 | Besse Forest Products               |
| 8 | 734 | 01 | 02 | J.E.Laird Farms                     |
| 8 | 735 | 01 | 01 | J.E.Laird Farms                     |
| 8 | 736 | 01 | 06 | Lyons Dist. Center                  |



ZONE 8

Rev 12/12/96

PAGE 6

|   |     |    |    |                        |
|---|-----|----|----|------------------------|
| 8 | 201 | 00 | 00 | Chicago - Line - Tk.#1 |
| 8 | 202 | 00 | 00 | Chicago - Line - Tk.#2 |
| 8 | 233 | 00 | 00 | Controlled - Siding    |
| 8 | 238 | 00 | 00 | Lead - Tk.#N 80        |
| 8 | 240 | 00 | 00 | Ind. Lead - Tk.        |
| 8 | 737 | 01 | 02 | La Roche Chemicals     |
| 8 | 738 | 01 | 02 | Hydro Kirby            |
| 8 | 739 | 01 | 04 | Hydro Kirby            |
| 8 | 741 | 01 | 08 | Agway - Fertilizer     |
| 8 | 742 | 01 | 02 | Agway - Fertilizer     |
| 8 | 743 | 01 | 05 | Agway - Fertilizer     |

LYONS NY

CLYDE NY

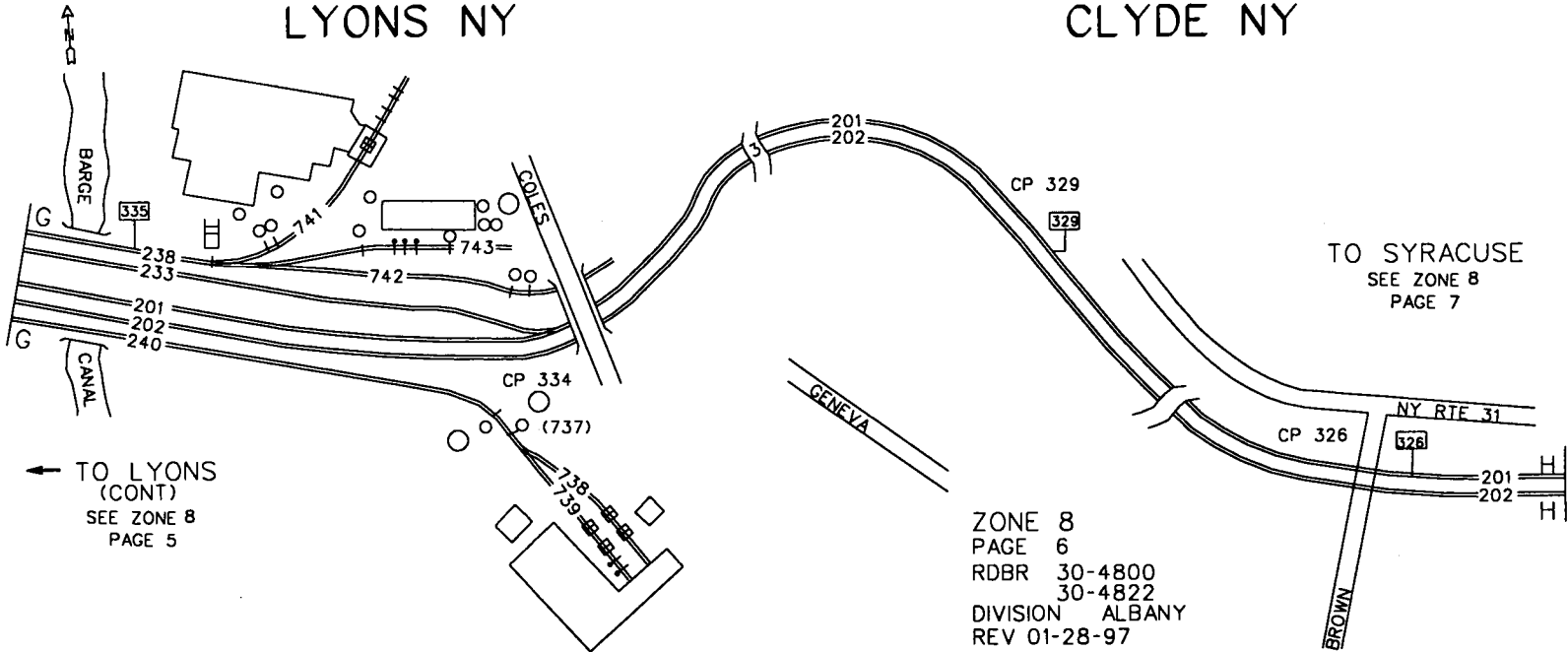

ZONE 08

Rev 04/01/94

PAGE 7

08 201 00 00 Chicago - Line - Tk.#1  
08 202 00 00 Chicago - Line - Tk.#2  
08 244 00 00 North - Controlled - Siding  
08 549 00 00 Bridge & Building Department  
08 748 01 01 Vacant

# SAVANNAH NY

AS-2

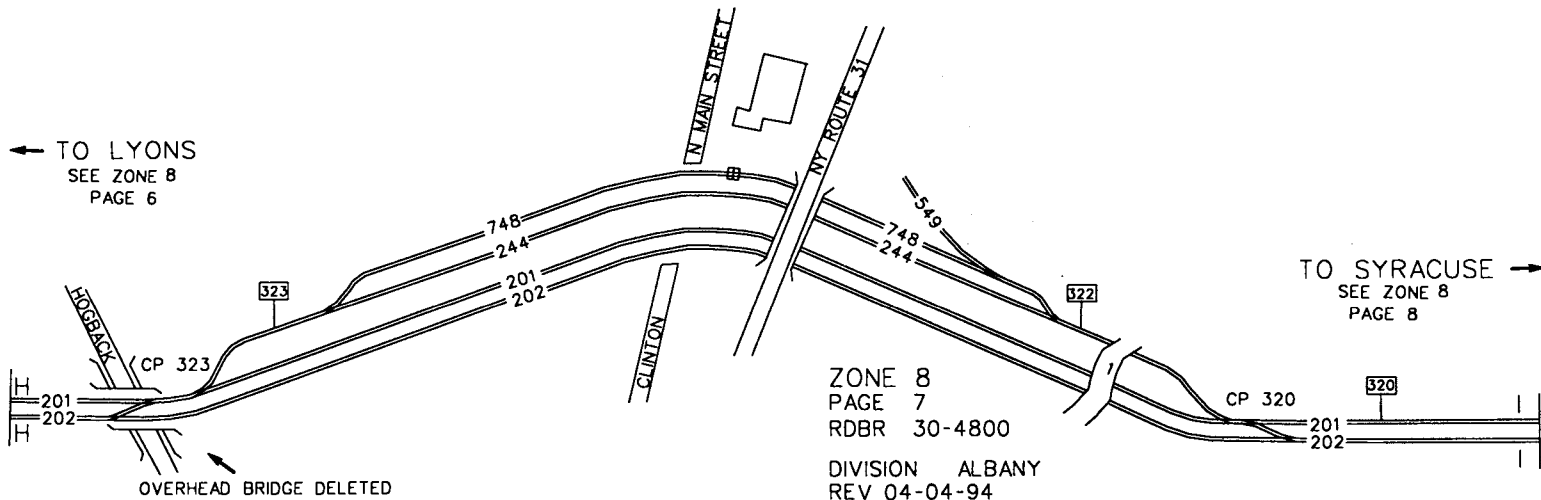

← TO LYONS  
SEE ZONE 8  
PAGE 6

TO SYRACUSE →  
SEE ZONE 8  
PAGE 8

ZONE 8  
PAGE 7  
RDBR 30-4800  
DIVISION ALBANY  
REV 04-04-94



ZONE 8

Rev 12/12/96

PAGE 8

- 8 201 00 00 Chicago - Line - Tk.#1
- 8 202 00 00 Chicago - Line - Tk.#2
- 8 250 00 00 Ind. Lead - Tk.
- 8 252 00 00 A.D.M. Lead
- 8 253 00 00 A.D.M. Lead
- 8 751 99 99 A.D.M. Tk.#1
- 8 752 99 99 A.D.M. Tk.#2
- 8 753 99 99 A.D.M. Tk.#3
- 8 754 99 99 A.D.M. Tk.#4
- 8 755 99 99 A.D.M. Scale Tk.
- 8 761 99 99 A.D.M. Syrup - Yd. Tk.#1
- 8 762 99 99 A.D.M. Syrup - Yd. Tk.#2
- 8 763 99 99 A.D.M. Syrup - Yd. Tk.#3
- 8 764 99 99 A.D.M. Syrup - Yd. Tk.#4
- 8 765 99 99 A.D.M. Syrup - Yd. Tk.#5



# FOXRIDGE NY

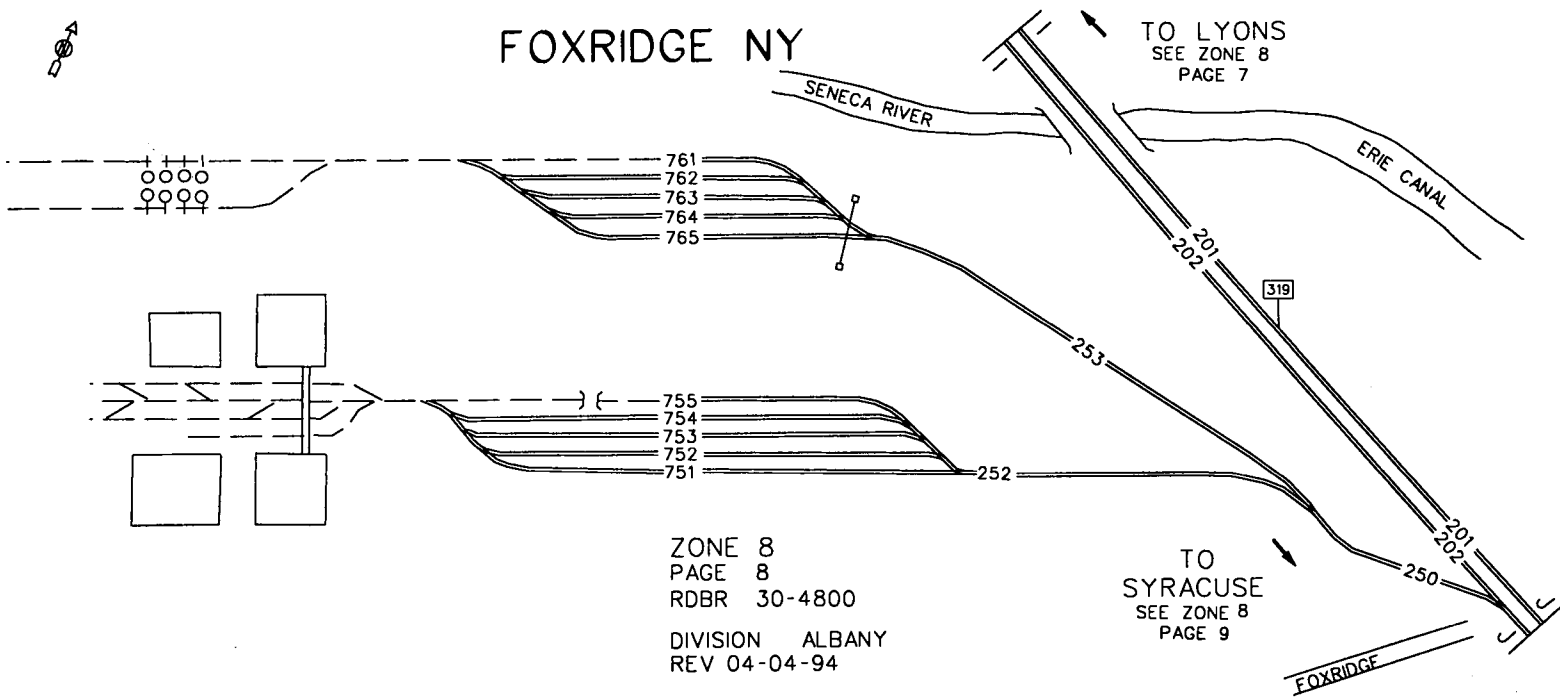

TO LYONS  
SEE ZONE 8  
PAGE 7

761  
762  
763  
764  
765

755  
754  
753  
752  
751

319

ZONE 8  
PAGE 8  
RDBR 30-4800  
DIVISION ALBANY  
REV 04-04-94

TO SYRACUSE  
SEE ZONE 8  
PAGE 9

FOXRIDGE

ZONE 8

Rev 12/12/96

PAGE 9

8 201 00 00 Chicago - Line - Tk.#1

8 202 00 00 Chicago - Line - Tk.#2

NORTH PORT BYRON NY

NORTH WEEDSPORT NY

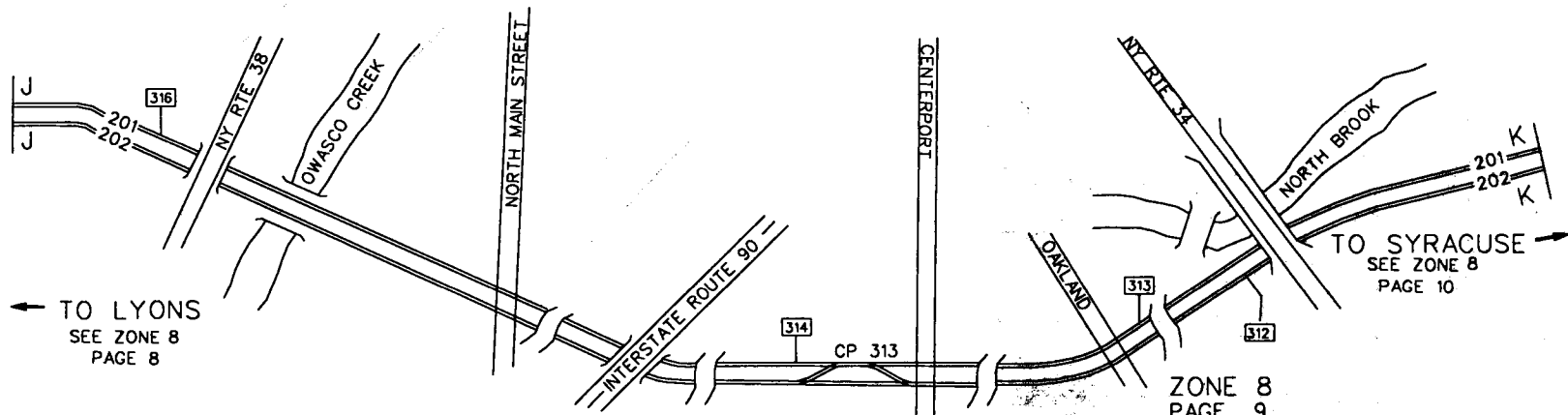

ZONE 8  
PAGE 9  
RDBR 48-4800  
DIVISION ALBANY  
REV 03-27-96

**ZONE 8**

**Rev 12/12/96**

**PAGE 10**

8 201 00 00 Chicago - Line - Tk.#1  
8 202 00 00 Chicago - Line - Tk.#2  
8 255 00 00 Controlled - Siding  
8 770 97 97 Plainville Turkey Farm  
8 770 97 97 Phillip Keller  
8 770 97 97 Georgia Pacific  
8 770 97 97 (Team Tk.)  
8 771 01 04 Wheeler Agway

# JORDAN NY



← TO LYONS  
SEE ZONE 8  
PAGE 9

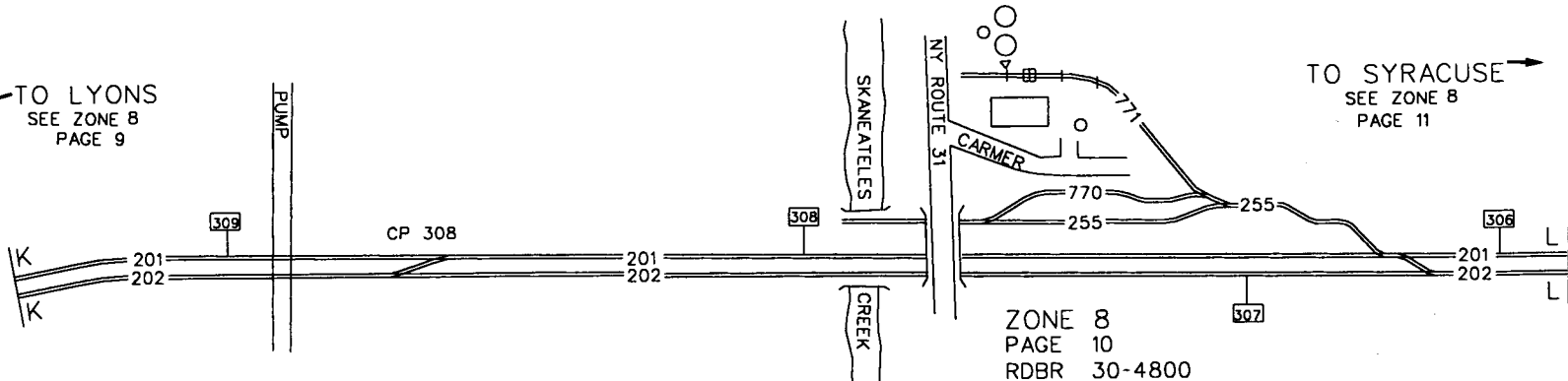

→ TO SYRACUSE  
SEE ZONE 8  
PAGE 11

ZONE 8  
PAGE 10  
RDBR 30-4800

DIVISION ALBANY  
REV 04-04-94

ZONE 8

Rev 12/12/96

PAGE 11

- 8 201 00 00 Chicago - Line - Tk.#1
- 8 202 00 00 Chicago - Line - Tk.#2
- 8 283 00 00 Controlled - Siding

WARNERS NY

BELLE ISLE NY

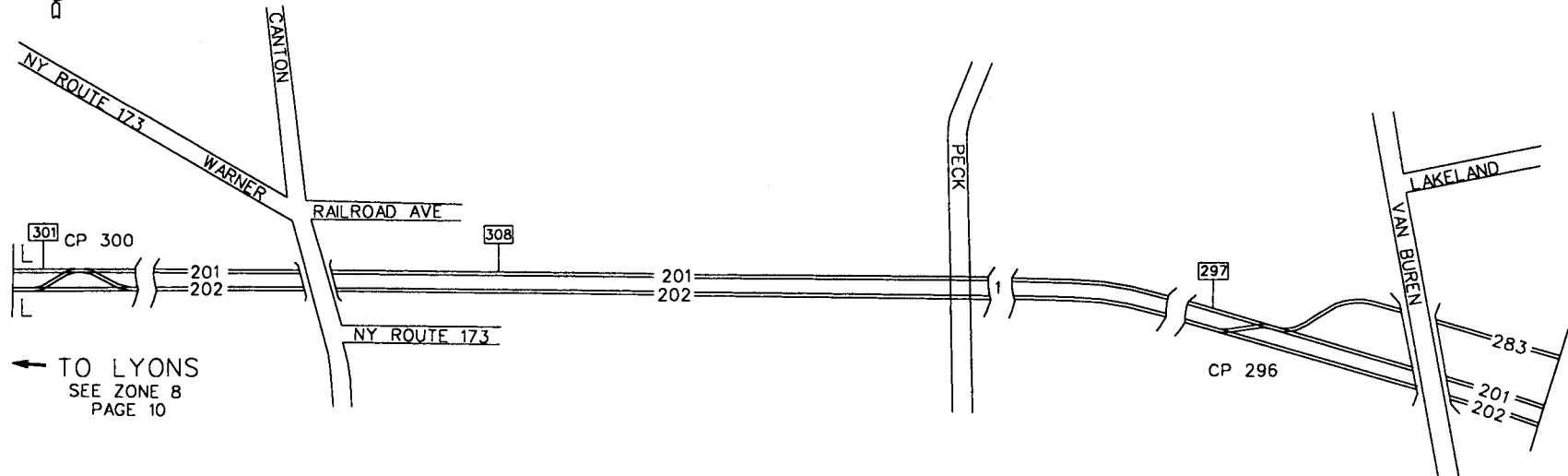

← TO LYONS  
SEE ZONE 8  
PAGE 10

ZONE 8  
PAGE 11  
RDBR 30-4800

TO SYRACUSE →  
SEE ZONE 85  
PAGE 21

DIVISION ALBANY  
REV 11-01-96





# GENEVA ZONE 9

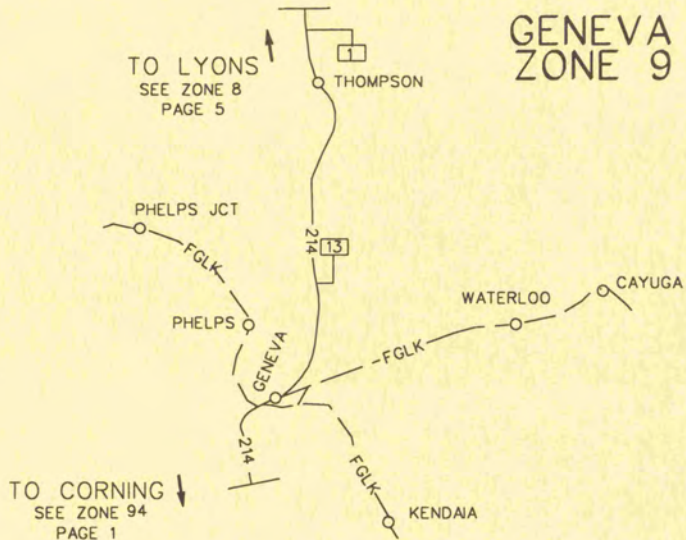

| TRACK SEGMENT     | ZTS TRK |
|-------------------|---------|
| CORNING SECONDARY | 214     |

REV 12-12-96

ZONE 9

Rev 12/26/96

PAGE 1

9 210 00 00 Passing - Siding  
9 212 00 00 Doves - Siding  
9 214 00 00 Coming - Secondary  
9 215 00 00 Coming - Running Track - South Leg  
9 711 01 01 Vacant - (Former A.J. Decoster)  
9 712 01 01 Vacant - (Former A.J. Decoster)

THOMPSON NY

GENEVA NY

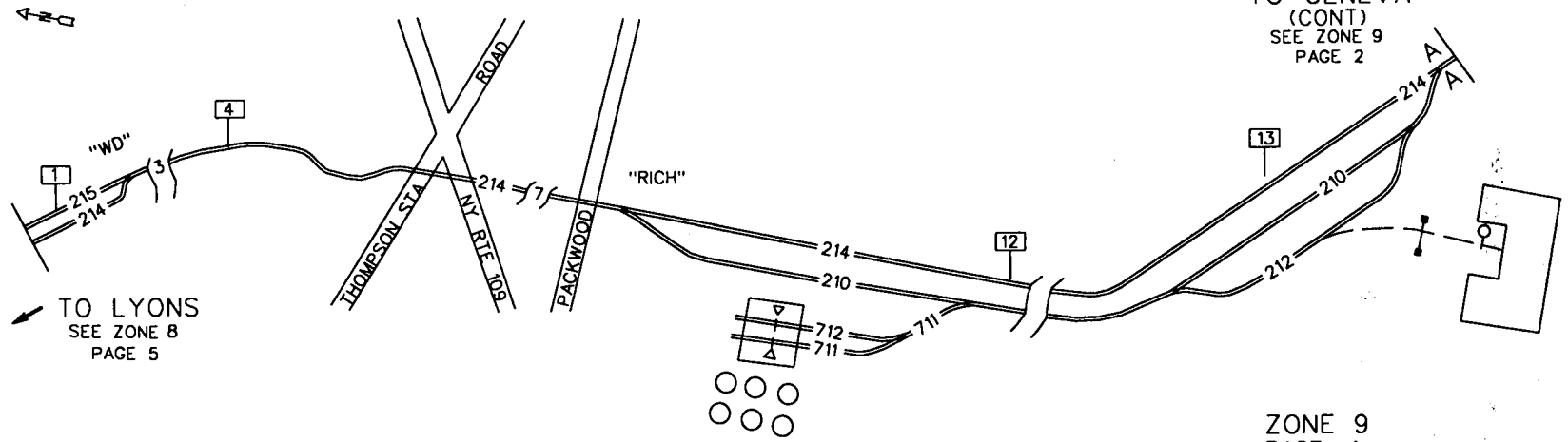

TO GENEVA  
(CONT)  
SEE ZONE 9  
PAGE 2

TO LYONS  
SEE ZONE 8  
PAGE 5

ZONE 9  
PAGE 1  
RDBR 30-4822

DIVISION ALBANY  
REV 12-06-96

**ZONE 9**

**Rev 12/12/96**

**PAGE 2**

**9 214 00 00 Coming - Secondary**

GENEVA NY

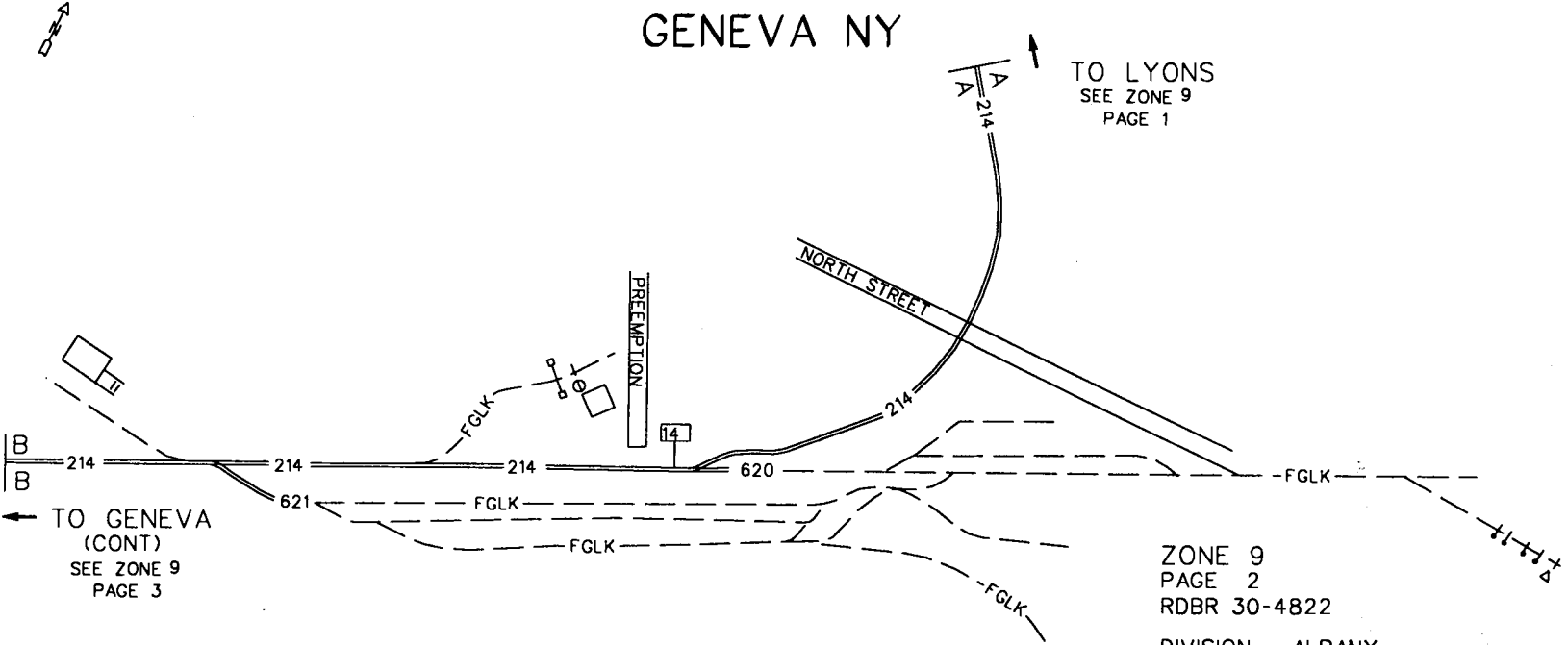

↑  
TO LYONS  
SEE ZONE 9  
PAGE 1

← TO GENEVA  
(CONT)  
SEE ZONE 9  
PAGE 3

ZONE 9  
PAGE 2  
RDBR 30-4822

DIVISION ALBANY  
REV 07-22-96

ZONE 9

Rev 12/12/96

PAGE 3

9 214 00 00 Coming - Secondary

# GENEVA NY

TO GENEVA  
(CONT)  
SEE ZONE 9  
PAGE 2

"CANA"

TO HIMROD JCT  
SEE ZONE 94  
PAGE 1

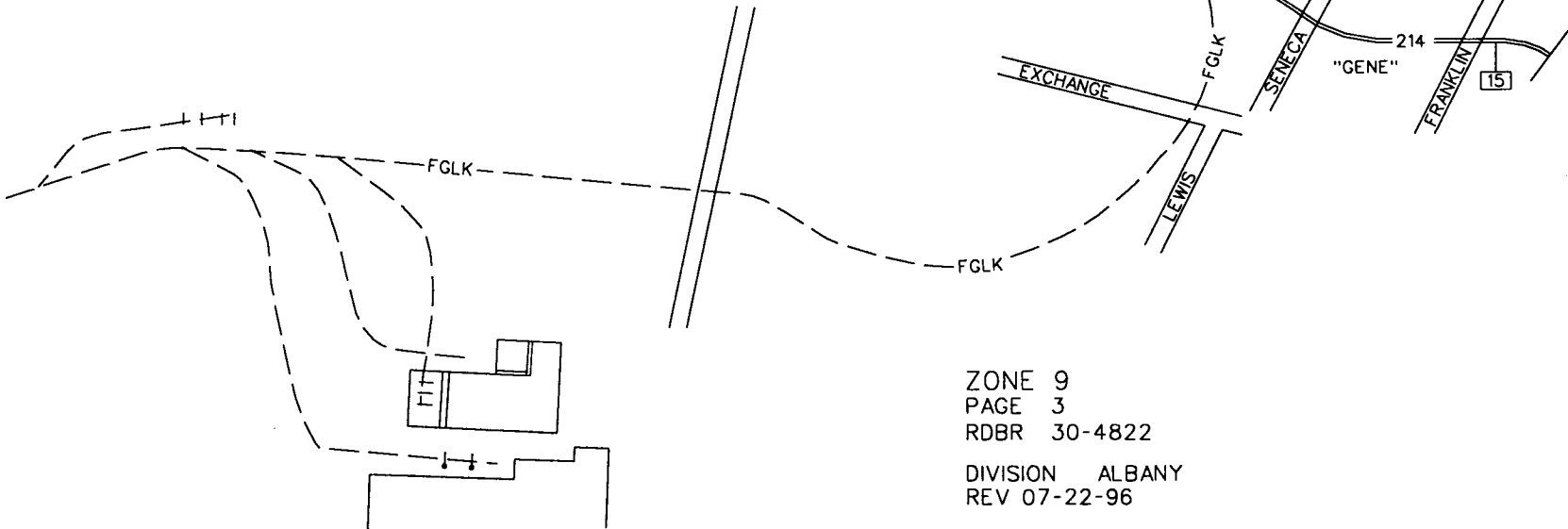

ZONE 9  
PAGE 3  
RDBR 30-4822

DIVISION ALBANY  
REV 07-22-96

D-27

# ERIE - ZONE 26

ERIE

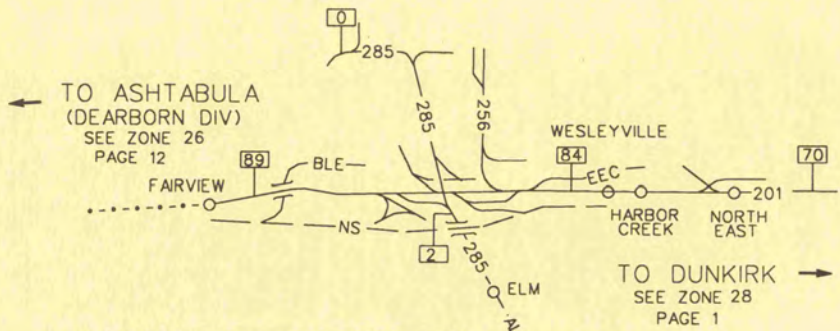

TO ASHTABULA  
(DEARBORN DIV)  
SEE ZONE 26  
PAGE 12

TO DUNKIRK  
SEE ZONE 28  
PAGE 1

TO EMPORIUM  
(VIA ALY)  
SEE ZONE 68  
PAGE 3

| TRACK SEGMENT        | ZTS TRK |
|----------------------|---------|
| CHICAGO LINE         | 201     |
| HAMMERMILL LEAD      | 256     |
| ERIE YARD INDUSTRIAL | 285     |

REV 12-27-96



ZONE 26

Rev 12/18/96

PAGE 1

|    |     |    |    |                        |
|----|-----|----|----|------------------------|
| 26 | 201 | 00 | 00 | Chicago - Line - Tk.#1 |
| 26 | 202 | 00 | 00 | Chicago - Line - Tk.#2 |
| 26 | 207 | 00 | 00 | Pyramid - Tk. Lead     |
| 26 | 208 | 00 | 00 | Runner - Tk.#42        |
| 26 | 702 | 01 | 10 | General Polymers       |

FAIRVIEW PA

ERIE PA

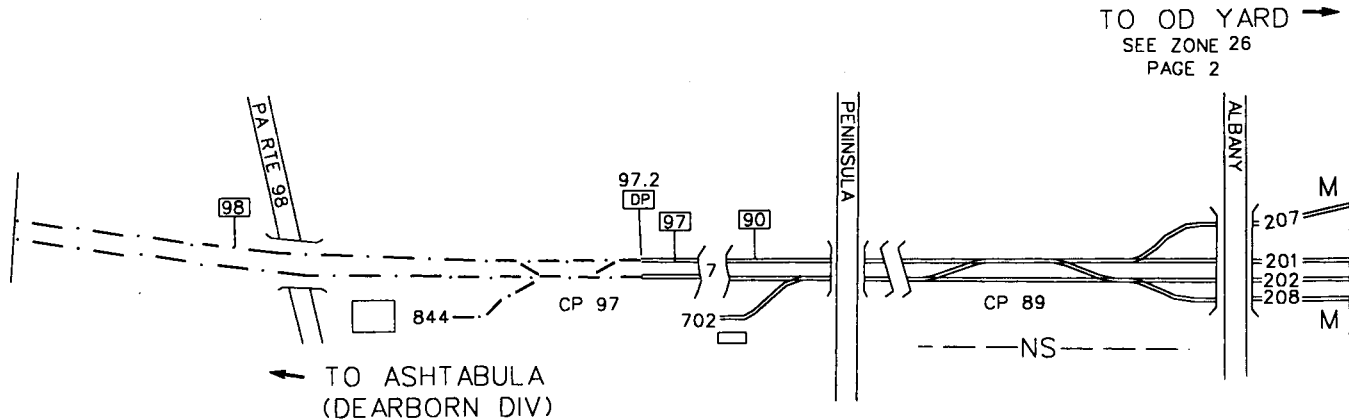

← TO ASHTABULA  
 (DEARBORN DIV)  
 SEE ZONE 26  
 PAGE 12

TO OD YARD →  
 SEE ZONE 26  
 PAGE 2

ZONE 26  
 PAGE 1  
 RDBR 30-3500  
 DIVISION ALBANY  
 REV 10-10-96

ZONE 26

Rev 12/17/96

PAGE 2

|    |     |    |    |                            |
|----|-----|----|----|----------------------------|
| 26 | 201 | 00 | 00 | Chicago - Line - Tk.#1     |
| 26 | 202 | 00 | 00 | Chicago - Line - Tk.#2     |
| 26 | 207 | 00 | 00 | Pyramid - Tk. Lead         |
| 26 | 208 | 00 | 00 | Runner - Tk.#42            |
| 26 | 210 | 00 | 00 | North - Runner - Tk.       |
| 26 | 212 | 00 | 00 | Forge - Tk. Lead           |
| 26 | 601 | 00 | 00 | (BLE) - I/C - Tk.          |
| 26 | 703 | 01 | 03 | Pyramid - Industries - Tk. |
| 26 | 704 | 01 | 02 | Erie Concrete              |
| 26 | 705 | 01 | 02 | Hamilton Lumber            |
| 26 | 710 | 99 | 99 | Erie Forge Steel           |
| 26 | 712 | 01 | 04 | Riley Stoker Corp          |
| 26 | 713 | 01 | 03 | Riley Stoker Corp          |
| 26 | 714 | 99 | 99 | Riley Stoker Corp          |
| 26 | 715 | 01 | 02 | Riley Stoker Corp          |
| 26 | 716 | 01 | 01 | Riley Stoker Corp          |
| 26 | 717 | 99 | 99 | Riley Stoker Corp          |



# ERIE PA

TO ERIE  
(CONT)  
SEE ZONE 26  
PAGE 1

TO OD YARD →  
SEE ZONE 26  
PAGE 3

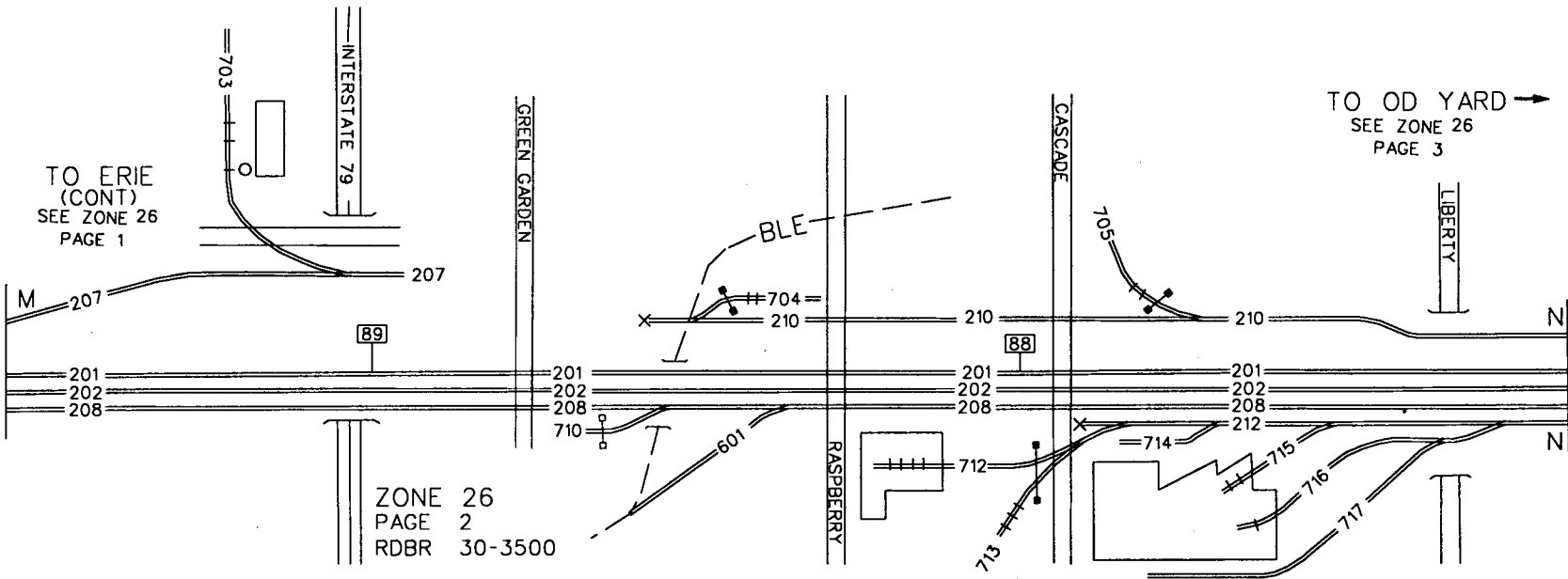

ZONE 26  
PAGE 2  
RDBR 30-3500

DIVISION ALBANY  
REV 01-01-92

ZONE 26

Rev 12/17/96

PAGE 3

|    |     |    |    |                                     |
|----|-----|----|----|-------------------------------------|
| 26 | 201 | 00 | 00 | Chicago - Line - Tk.#1              |
| 26 | 202 | 00 | 00 | Chicago - Line - Tk.#2              |
| 26 | 208 | 00 | 00 | Runner - Tk.#42                     |
| 26 | 210 | 00 | 00 | North - Runner - Tk.                |
| 26 | 212 | 00 | 00 | Forge - Tk. Lead                    |
| 26 | 214 | 00 | 00 | Ind. Lead - Tk.                     |
| 26 | 216 | 00 | 00 | Ind. Lead - Tk.                     |
| 26 | 540 | 00 | 00 | M of W Track                        |
| 26 | 541 | 00 | 00 | M of W Track                        |
| 26 | 602 | 00 | 00 | Erie - Yd. Tk.#2                    |
| 26 | 606 | 00 | 00 | Erie - Yd. Tk.#6                    |
| 26 | 607 | 00 | 00 | Erie - Yd. Tk.#7                    |
| 26 | 720 | 01 | 02 | Times Publishing                    |
| 26 | 721 | 01 | 04 | Rapid Transit                       |
| 26 | 722 | 01 | 13 | Plastek Industries (Leased 750 Ft.) |
| 26 | 725 | 01 | 09 | Plastek Industries (Leased 500 Ft.) |
| 26 | 726 | 01 | 01 | United Erie                         |



# ERIE PA

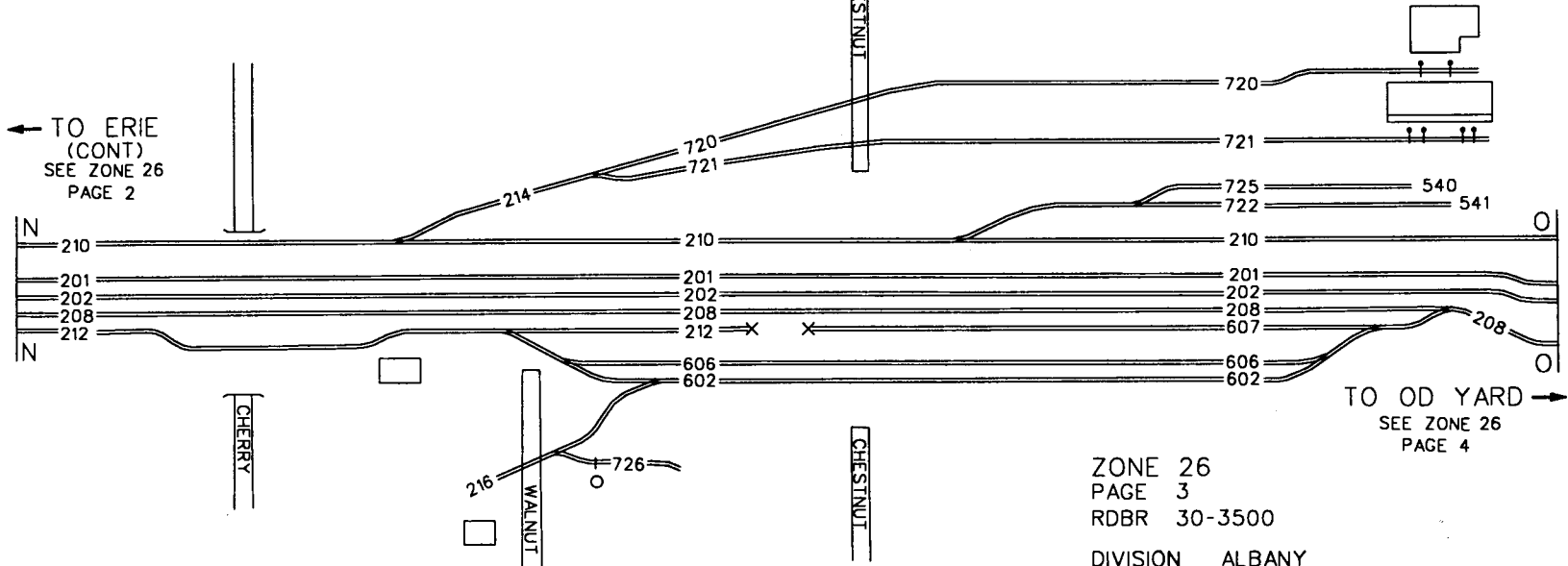

← TO ERIE  
(CONT)  
SEE ZONE 26  
PAGE 2

TO OD YARD →  
SEE ZONE 26  
PAGE 4

ZONE 26  
PAGE 3  
RDBR 30-3500  
DIVISION ALBANY  
REV 12-01-96

ZONE 26

Rev 12/17/96

PAGE 4

|    |     |    |    |                        |
|----|-----|----|----|------------------------|
| 26 | 201 | 00 | 00 | Chicago - Line - Tk.#1 |
| 26 | 202 | 00 | 00 | Chicago - Line - Tk.#2 |
| 26 | 208 | 00 | 00 | Runner - Tk.#42        |
| 26 | 210 | 00 | 00 | North - Runner - Tk.   |
| 26 | 219 | 00 | 00 | Lead                   |
| 26 | 733 | 01 | 02 | Vacant                 |
| 26 | 734 | 99 | 99 | Vacant                 |
| 26 | 735 | 01 | 01 | Vacant                 |
| 26 | 736 | 01 | 04 | Vacant                 |
| 26 | 737 | 01 | 04 | Vacant                 |
| 26 | 738 | 99 | 99 | Vacant                 |

# ERIE PA

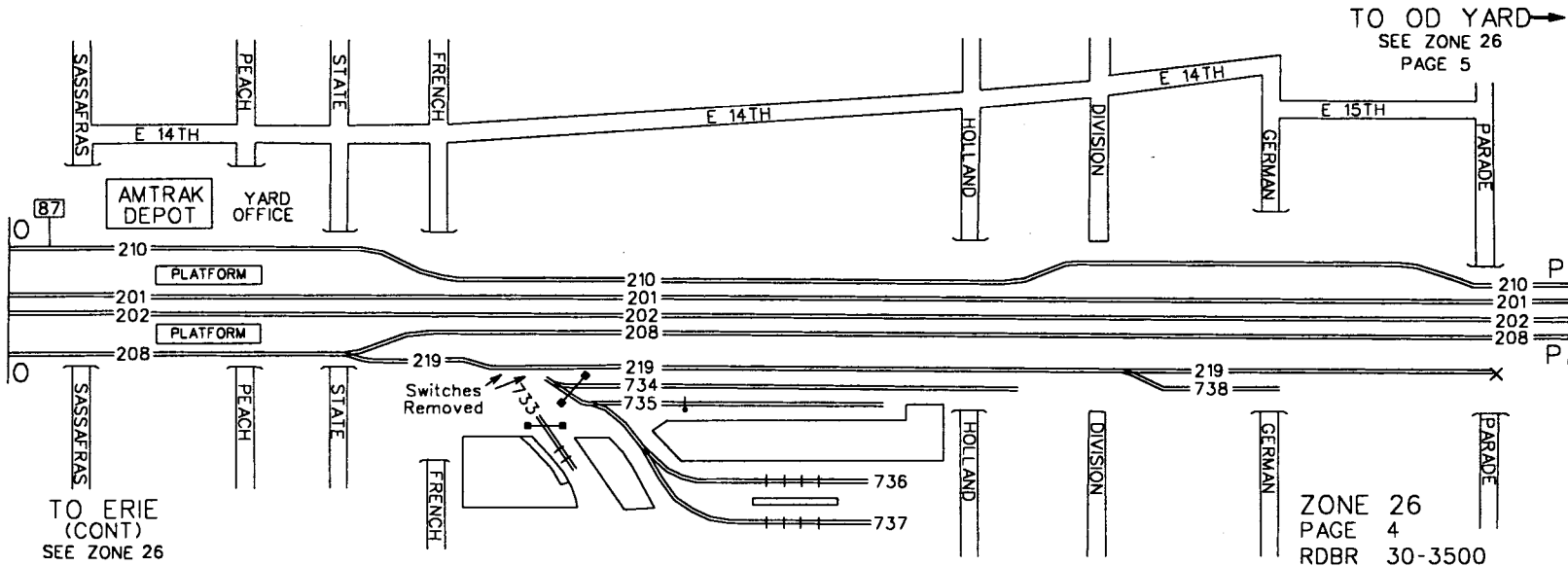

TO OD YARD →  
SEE ZONE 26  
PAGE 5

TO ERIE  
(CONT)  
SEE ZONE 26  
PAGE 3

ZONE 26  
PAGE 4  
RDBR 30-3500

DIVISION ALBANY  
REV 01-01-92



- 26 201 00 00 Chicago - Line - Tk.#1
- 26 202 00 00 Chicago - Line - Tk.#2
- 26 208 00 00 Runner - Tk.#42
- 26 210 00 00 North - Runner - Tk.
- 26 223 00 00 Liberty Iron - Tk. Lead
- 26 224 00 00 O D - Yd. Tk. Lead
- 26 226 00 00 West - Leg of - Wye - Tk.
- 26 230 00 00 O D - Yd. Tk. Lead
- 26 237 00 00 Ind. Lead - Tk.
- 26 285 00 00 Erie - Yd. Ind. Tk.
- 26 620 00 00 O D - Tk.#10
- 26 625 00 00 O D - Tk.#5
- 26 627 00 00 O D - Tk.#7
- 26 739 99 99 Erie City Iron - Tk. (I/B & O/B)
- 26 741 99 99 Liberty Iron Metal - Extension
- 26 747 99 99 Liberty Iron Metal - Pokey - Tk.
- 26 748 99 99 Liberty Iron Metal
- 26 749 99 99 Liberty Iron Metal - Coal - Tk.
- 26 751 99 99 Erie City Iron - Tk. (O/B)

# ERIE PA

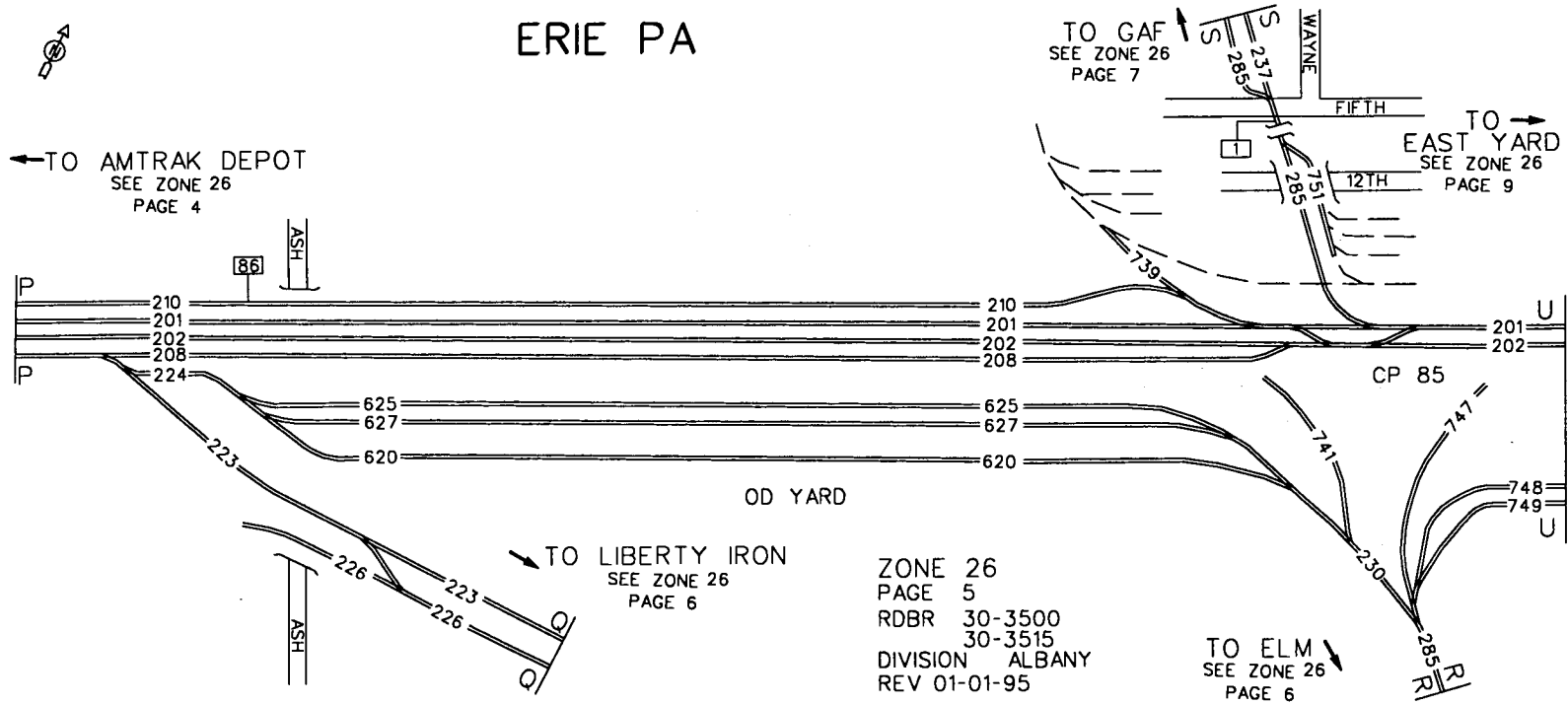

← TO AMTRAK DEPOT  
SEE ZONE 26  
PAGE 4

↑ TO GAF  
SEE ZONE 26  
PAGE 7

→ TO EAST YARD  
SEE ZONE 26  
PAGE 9

OD YARD

→ TO LIBERTY IRON  
SEE ZONE 26  
PAGE 6

ZONE 26  
PAGE 5  
RDBR 30-3500  
30-3515  
DIVISION ALBANY  
REV 01-01-95

↓ TO ELM  
SEE ZONE 26  
PAGE 6

ZONE 26

Rev 12/17/96

PAGE 6

26 223 00 00 Liberty Iron - Tk. Lead  
26 226 00 00 West - Leg of - Wye - Tk.  
26 227 00 00 E. Leg of Wye - S.Liberty Iron Lead  
26 232 00 00 Ind. Lead - Tk.  
26 285 00 00 Erie - Yd. Ind. Tk.  
26 743 99 99 Liberty Iron - Tk.  
26 745 00 00 Vacant



TO  
OD YARD  
SEE ZONE 26  
PAGE 5

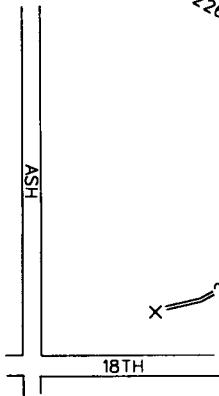

ERIE PA

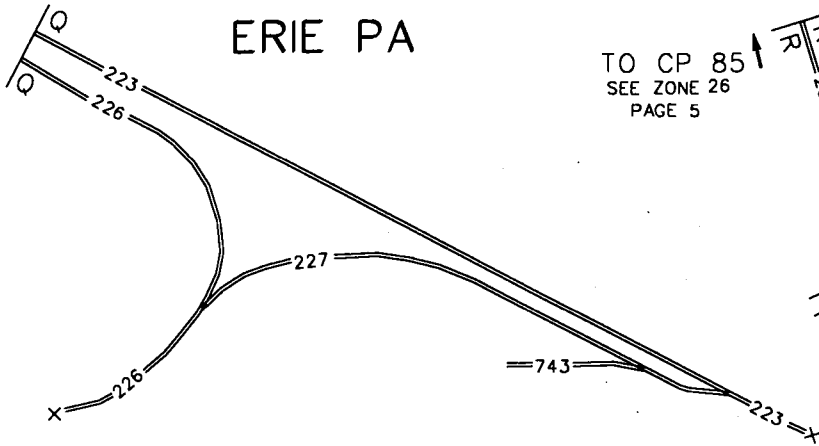

TO CP 85  
SEE ZONE 26  
PAGE 5

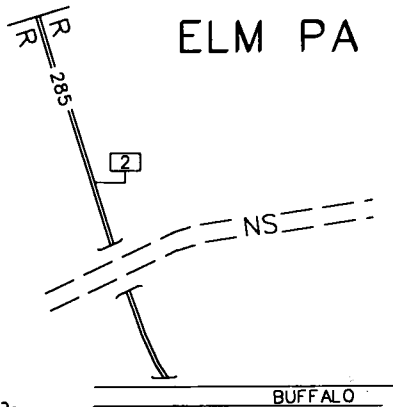

ELM PA

ZONE 26  
PAGE 6  
RDBR 30-3500  
30-3515  
DIVISION ALBANY  
REV 01-01-95

TO EMPORIUM  
(VIA ALY)  
SEE ZONE 68  
PAGE 3

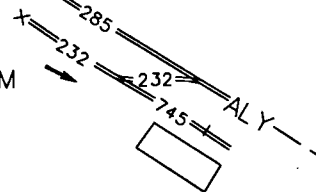

|    |     |    |    |                                    |
|----|-----|----|----|------------------------------------|
| 26 | 237 | 00 | 00 | Ind. Lead - Tk.                    |
| 26 | 239 | 00 | 00 | Whalen - Tk.#1                     |
| 26 | 240 | 00 | 00 | Whalen - Tk.#2                     |
| 26 | 242 | 00 | 00 | Codan - Lead - Tk.                 |
| 26 | 244 | 00 | 00 | Runner - Tk.#50                    |
| 26 | 285 | 00 | 00 | Erie - Yd. Ind. Tk.                |
| 26 | 631 | 00 | 00 | Southside - Tk.#1                  |
| 26 | 632 | 00 | 00 | Southside - Tk.#2                  |
| 26 | 633 | 00 | 00 | Thorofare - Tk.                    |
| 26 | 757 | 99 | 99 | Erie Coke - Ore - I/B - Tk.        |
| 26 | 758 | 99 | 99 | Erie Coke - Coal - I/B - Tk.       |
| 26 | 759 | 99 | 99 | Erie Coke - Coke - O/B - Tk.       |
| 26 | 760 | 99 | 99 | Erie Coke - Backcourse - I/B - Tk. |
| 26 | 762 | 01 | 01 | Erie Waste                         |
| 26 | 763 | 01 | 01 | Erie Waste                         |
| 26 | 764 | 01 | 01 | Erie Waste                         |
| 26 | 766 | 99 | 99 | Mount Fort Terminal                |
| 26 | 767 | 01 | 02 | Mount Fort Terminal                |

# ERIE PA

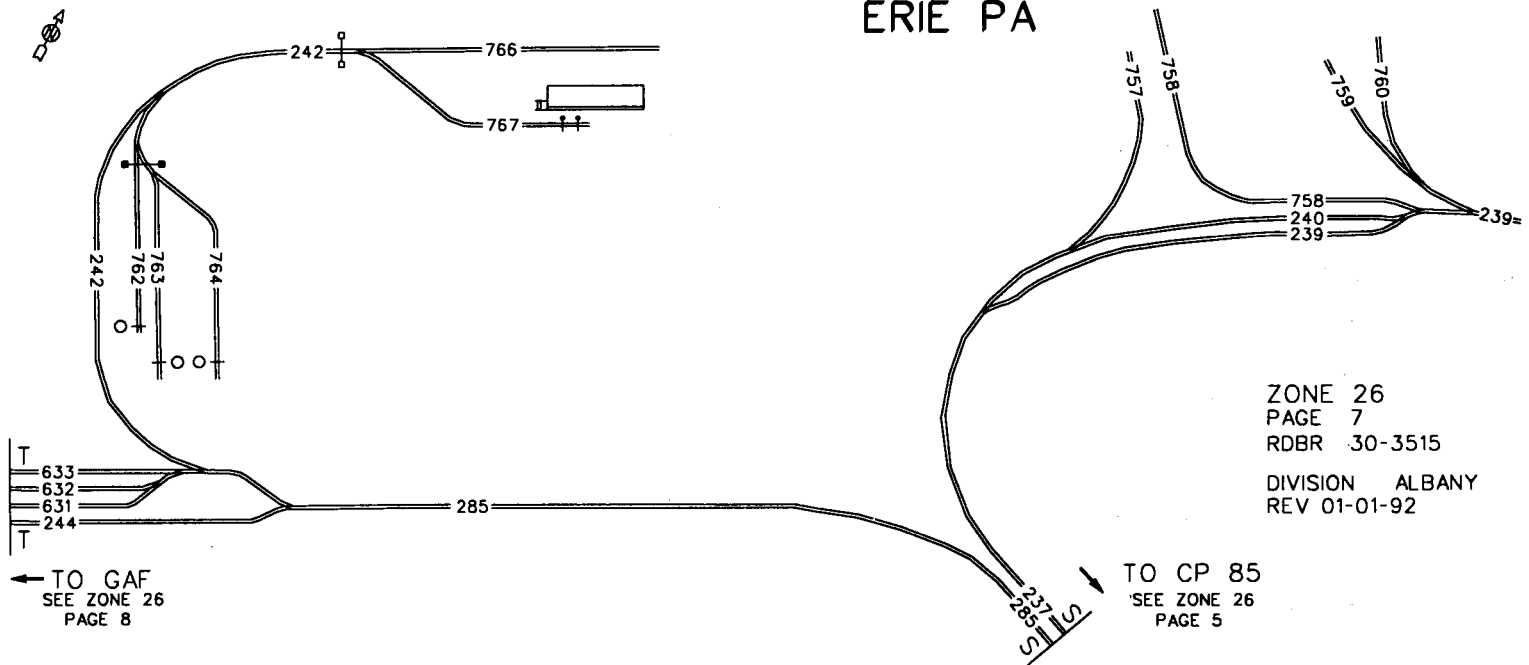

ZONE 26  
PAGE 7  
RDBR 30-3515

DIVISION ALBANY  
REV 01-01-92

← TO GAF  
SEE ZONE 26  
PAGE 8

TO CP 85  
SEE ZONE 26  
PAGE 5

ZONE 26

Rev 12/17/96

PAGE 8

|    |     |    |    |                   |
|----|-----|----|----|-------------------|
| 26 | 244 | 00 | 00 | Runner - Tk.#50   |
| 26 | 246 | 00 | 00 | Runner - Tk.#20   |
| 26 | 631 | 00 | 00 | Southside - Tk.#1 |
| 26 | 632 | 00 | 00 | Southside - Tk.#2 |
| 26 | 633 | 00 | 00 | Thorofare - Tk.   |
| 26 | 770 | 99 | 99 | GAF - Tk. Lead    |
| 26 | 771 | 01 | 04 | GAF - Tk.#1       |
| 26 | 773 | 99 | 99 | GAF - Tk.#3       |
| 26 | 774 | 01 | 01 | GAF - Tk.#4       |
| 26 | 775 | 99 | 99 | Vacant            |

ERIE PA

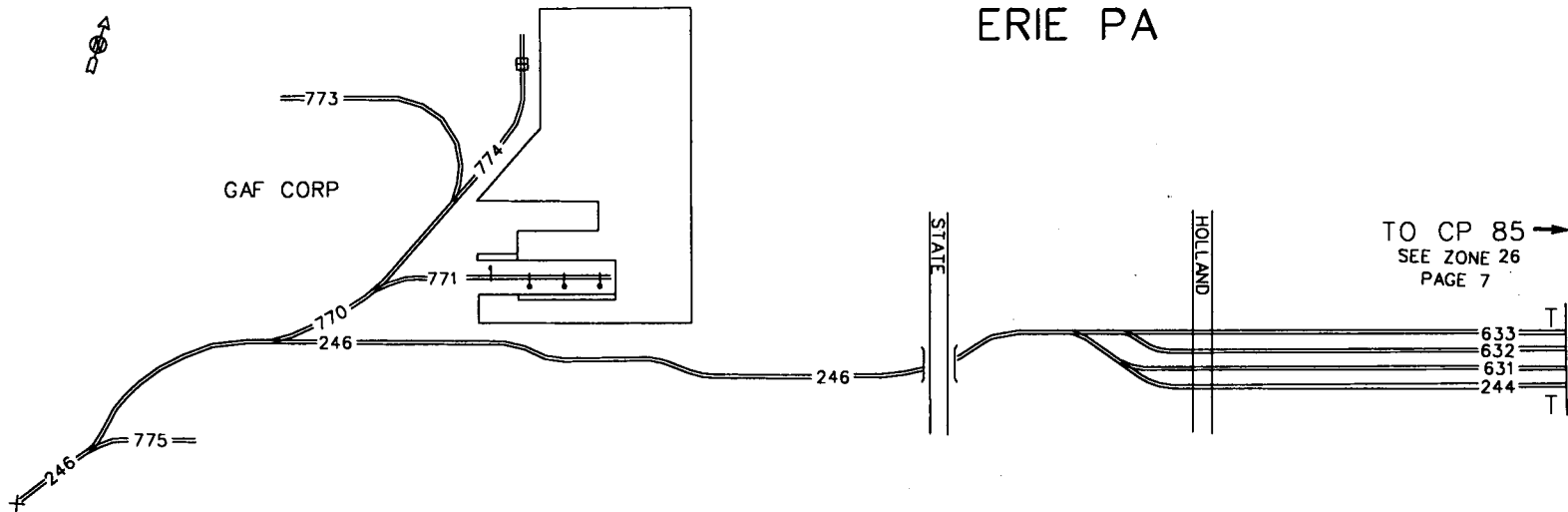

TO CP 85 →  
SEE ZONE 26  
PAGE 7

ZONE 26  
PAGE 8  
RDBR 30-3515  
DIVISION ALBANY  
REV 01-01-92



ZONE 26

Rev 12/17/96

PAGE 9

26 201 00 00 Chicago - Line - Tk.#1  
26 202 00 00 Chicago - Line - Tk.#2  
26 252 00 00 S. Controlled - Siding - Tk.  
26 253 00 00 Old - Tk.#3  
26 254 00 00 Scale - Tk.  
26 256 00 00 Hammermill Paper - Tk. Lead  
26 640 00 00 Erie - East - Yd. Rip Tk.  
26 641 00 00 Erie - East - Yd. Tk.#1  
26 642 00 00 Erie - East - Yd. Tk.#2  
26 643 00 00 Erie - East - Yd. Tk.#3  
26 644 00 00 Erie - East - Yd. Tk.#4  
26 646 00 00 Erie - East - Yd. Tk.#6  
26 646 97 97 Penn Electric  
26 647 00 00 (NS) - I/C - Tk.#7  
26 748 99 99 Liberty Iron Metal - Main - Tk.  
26 749 99 99 Liberty Iron Metal - Coal - Tk.



# ERIE PA

TO HAMMERMILL  
SEE ZONE 26  
PAGE 10



← TO OD YARD  
SEE ZONE 26  
PAGE 5

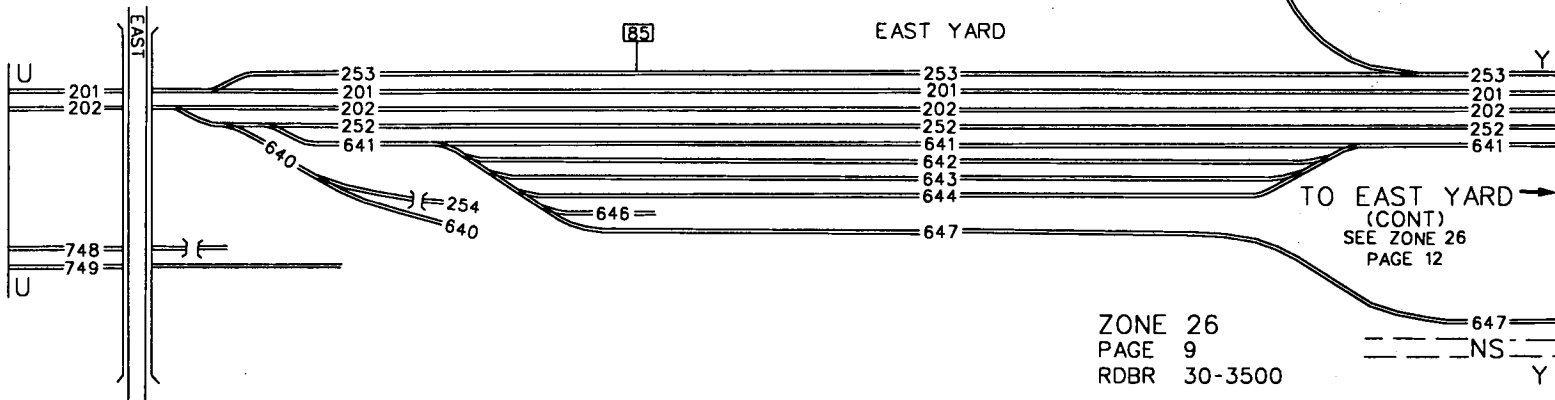

TO EAST YARD →  
(CONT)  
SEE ZONE 26  
PAGE 12

ZONE 26  
PAGE 9  
RDBR 30-3500

DIVISION ALBANY  
REV 01-01-92

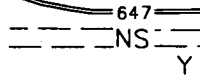

ZONE 26

Rev 12/17/96

PAGE 10

|    |     |    |    |                             |
|----|-----|----|----|-----------------------------|
| 26 | 256 | 00 | 00 | Hammermill Paper - Tk. Lead |
| 26 | 258 | 00 | 00 | 10th St. Lead - Tk.         |
| 26 | 807 | 01 | 04 | Inland Container            |
| 26 | 809 | 01 | 02 | Downing Cold Storage        |
| 26 | 811 | 01 | 02 | Erie Crate                  |

# ERIE PA

ZONE 26  
PAGE 10  
RDBR 30-3500

DIVISION ALBANY  
REV 01-01-92



↑ TO  
HAMMERMILL  
SEE ZONE 26  
PAGE 11

↓ TO EAST YARD  
SEE ZONE 26  
PAGE 9

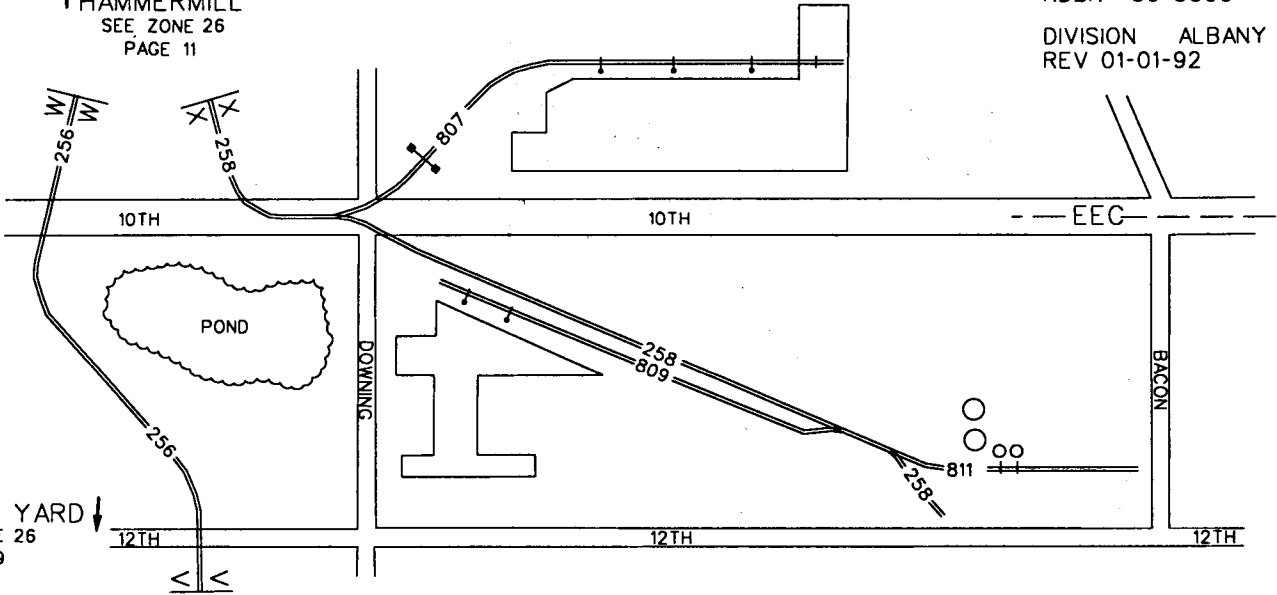

- 26 256 00 00 International Paper Tk. Lead
- 26 258 00 00 10th St. Lead - Tk.
- 26 784 99 99 International Paper Tk. Caustic Storage
- 26 785 99 99 International Paper Tk. Lead
- 26 786 99 99 International Paper Tk. Storage
- 26 787 99 99 International Paper Tk. S.E. - Mian
- 26 788 99 99 International Paper Tk# 12.
- 26 789 99 99 International Paper Tk# 28.
- 26 790 99 99 International Paper Tk# 27.
- 26 791 99 99 International Paper Tk# 11.
- 26 792 99 99 International Paper Tk# 10 1/2.
- 26 793 99 99 International Paper Tk# 10.
- 26 794 99 99 International Paper Tk E. Chlorine.
- 26 795 99 99 International Paper Tk W. Chlorine.
- 26 799 99 99 International Paper Tk# 19.
- 26 800 99 99 International Paper Tk# 20.
- 26 801 99 99 International Paper Tk# 21.
- 26 803 99 99 International Paper Tk S. Bnd Runaround.
- 26 804 99 99 International Paper Warehouse Tk#1.
- 26 805 01 08 International Paper Warehouse Tk#2.

# ERIE PA

(HAMMERMILL PAPER CO)



← TO EAST YARD  
SEE ZONE 26  
PAGE 10

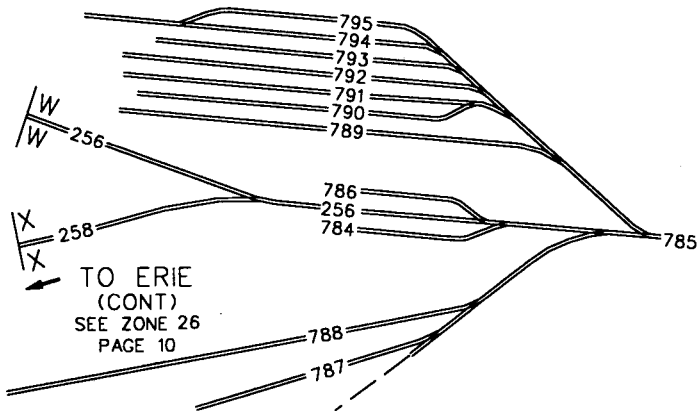

EAST LAKE

785

803

804

805



ZONE 26  
PAGE 11  
RDBR 30-3500

DIVISION ALBANY  
REV 01-01-92

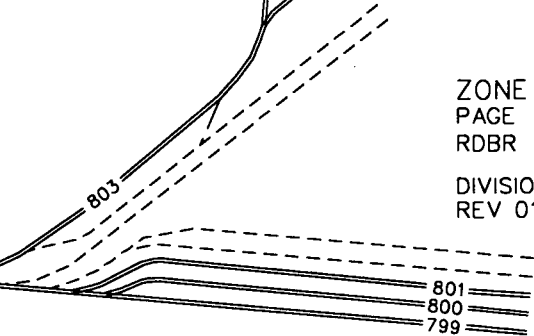

801

800

799

ZONE 26

Rev 12/17/96

PAGE 12

26 201 00 00 Chicago - Line - Tk.#1  
26 202 00 00 Chicago - Line - Tk.#2  
26 252 00 00 S. Controlled - Siding - Tk.  
26 253 00 00 Old - Tk.#3  
26 641 00 00 Erie - East - Yd. Tk.#1  
26 647 00 00 (NS) - I/C - Tk.  
26 651 00 00 (EEC RR) - I/C - S. Tk.  
26 652 00 00 (EEC RR) - I/C - N. Tk.  
26 653 00 00 (EEC RR) - I/C - Tk.



# ERIE PA

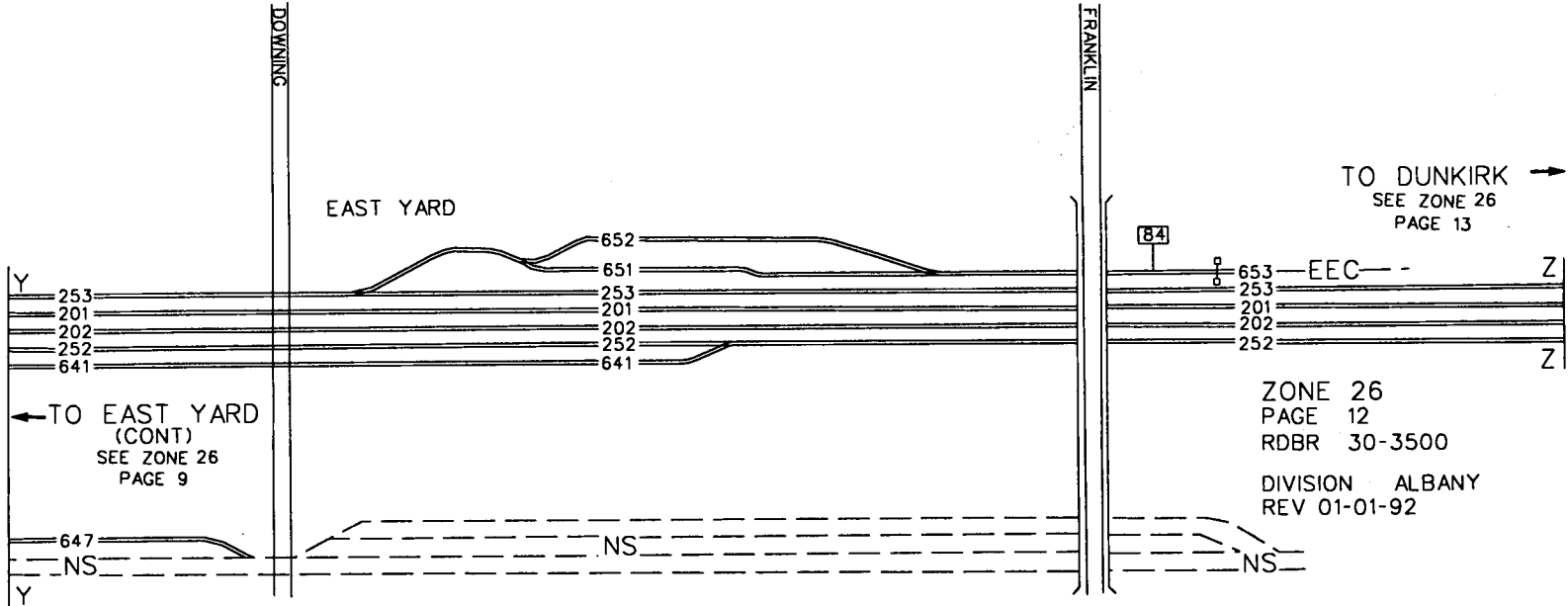

TO DUNKIRK →  
SEE ZONE 26  
PAGE 13

ZONE 26  
PAGE 12  
RDBR 30-3500

DIVISION ALBANY  
REV 01-01-92

← TO EAST YARD  
(CONT)  
SEE ZONE 26  
PAGE 9



ZONE 26

Rev 12/17/96

PAGE 13

|    |     |    |    |                              |
|----|-----|----|----|------------------------------|
| 26 | 201 | 00 | 00 | Chicago - Line - Tk.#1       |
| 26 | 202 | 00 | 00 | Chicago - Line - Tk.#2       |
| 26 | 252 | 00 | 00 | S. Controlled - Siding - Tk. |
| 26 | 253 | 00 | 00 | Old - Tk.#3                  |
| 26 | 660 | 00 | 00 | (NS) - Connection - Tk.      |



# WESLEYVILLE PA

# HARBOR CREEK PA

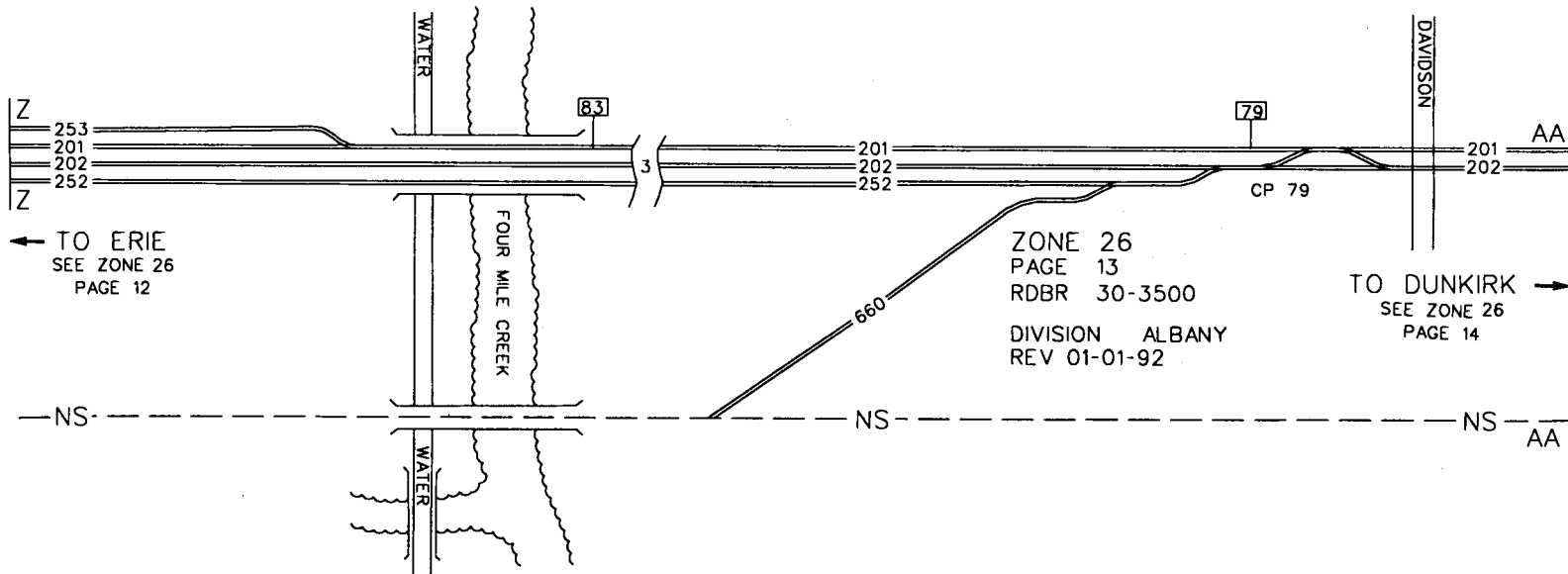

← TO ERIE  
SEE ZONE 26  
PAGE 12

ZONE 26  
PAGE 13  
RDBR 30-3500  
DIVISION ALBANY  
REV 01-01-92

TO DUNKIRK →  
SEE ZONE 26  
PAGE 14

ZONE 26

Rev 12/17/96

PAGE 14

|    |     |    |    |                            |
|----|-----|----|----|----------------------------|
| 26 | 201 | 00 | 00 | Chicago - Line - Tk.#1     |
| 26 | 202 | 00 | 00 | Chicago - Line - Tk.#2     |
| 26 | 266 | 00 | 00 | Ind. Lead - Tk.            |
| 26 | 815 | 97 | 97 | North East PA - (Team Tk.) |
| 26 | 817 | 01 | 03 | Customs Foods Limited      |
| 26 | 819 | 99 | 99 | Lake Shore RR Assoc. Tk.   |
| 26 | 820 | 99 | 99 | Lake Shore RR Assoc. Tk.   |
| 26 | 821 | 99 | 99 | Lake Shore RR Assoc. Tk.   |
| 26 | 822 | 99 | 99 | Lake Shore RR Assoc. Tk.   |
| 26 | 823 | 99 | 99 | Lake Shore RR Assoc. Tk.   |
| 26 | 824 | 99 | 99 | Lake Shore RR Assoc. Tk.   |



ZONE 26

Rev 12/17/96

PAGE 15

- 26 201 00 00 Chicago - Line - Tk.#1
- 26 202 00 00 Chicago - Line - Tk.#2
- 26 266 00 00 Ind. Lead - Tk.
- 26 267 00 00 Former - (Industrial - Lead)
- 26 826 01 05 Electric Materials
- 26 827 99 99 Electric Materials
- 26 829 99 99 84 Lumber



# NORTH EAST PA

← TO NORTHEAST  
(CONT)  
SEE ZONE 26  
PAGE 14

TO DUNKIRK →  
SEE ZONE 28  
PAGE 1

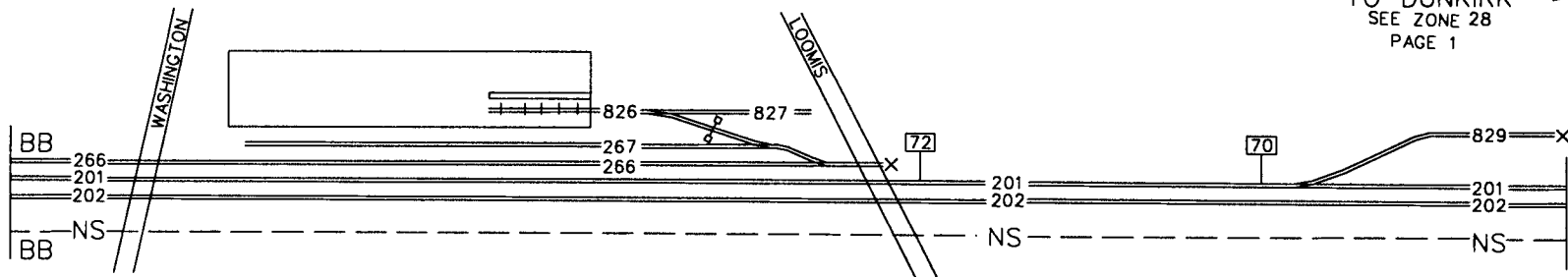

ZONE 26  
PAGE 15  
RDBR 30-3500  
DIVISION ALBANY  
REV 01-01-92

# DUNKIRK - ZONE 28

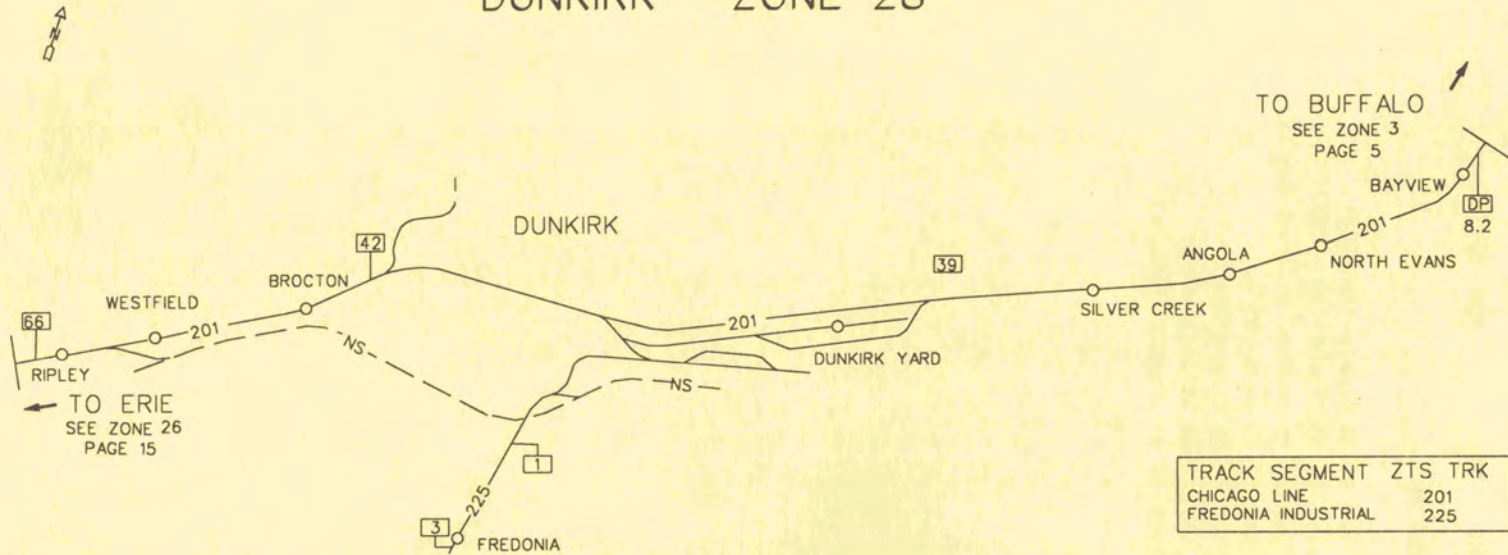

| TRACK SEGMENT       | ZTS | TRK |
|---------------------|-----|-----|
| CHICAGO LINE        | 201 |     |
| FREDONIA INDUSTRIAL | 225 |     |

ZONE 28

Rev 12/17/96

PAGE 1

28 201 00 00 Chicago - Line - Tk.#1  
28 202 00 00 Chicago - Line - Tk.#2  
28 210 00 00 Westfield - S. Control - Sdg. Tk.  
28 540 00 00 Camp Car - Tk.  
28 701 01 02 Growers Coop.  
28 703 01 03 Mogan David Wine  
28 705 97 97 Westfield - (Team Tk.)



# RIPLEY NY

# WESTFIELD NY

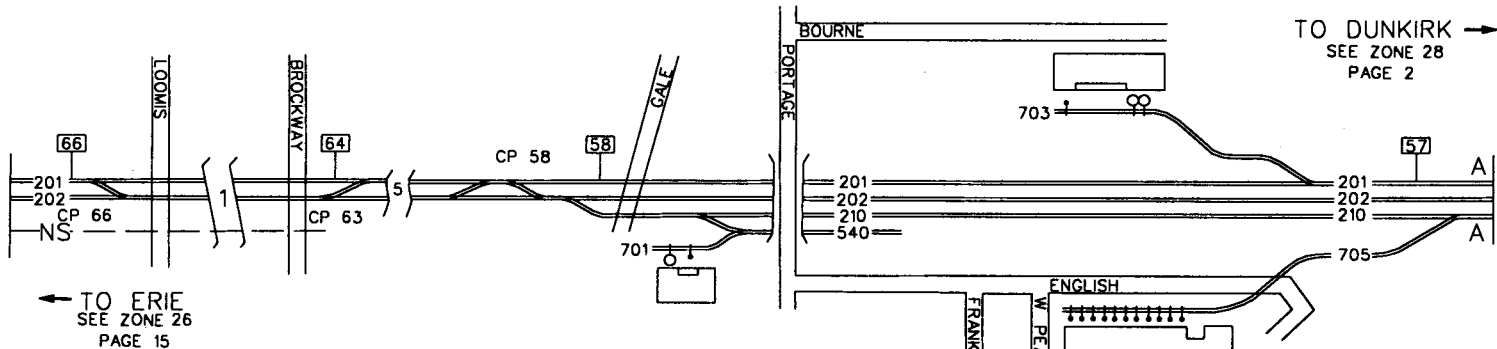

← TO ERIE  
SEE ZONE 26  
PAGE 15

TO DUNKIRK →  
SEE ZONE 28  
PAGE 2

ZONE 28  
PAGE 1  
RDBR 30-3500

DIVISION ALBANY  
REV 01-01-92

ZONE 28

Rev 01/01/95

PAGE 2

28 201 00 00 Chicago - Line - Tk.#1  
28 202 00 00 Chicago - Line - Tk.#2  
28 210 00 00 Westfield - S. Control - Sdg. Tk.  
28 601 00 00 (NS) - Connection - Tk.



WESTFIELD NY

BROCTON NY

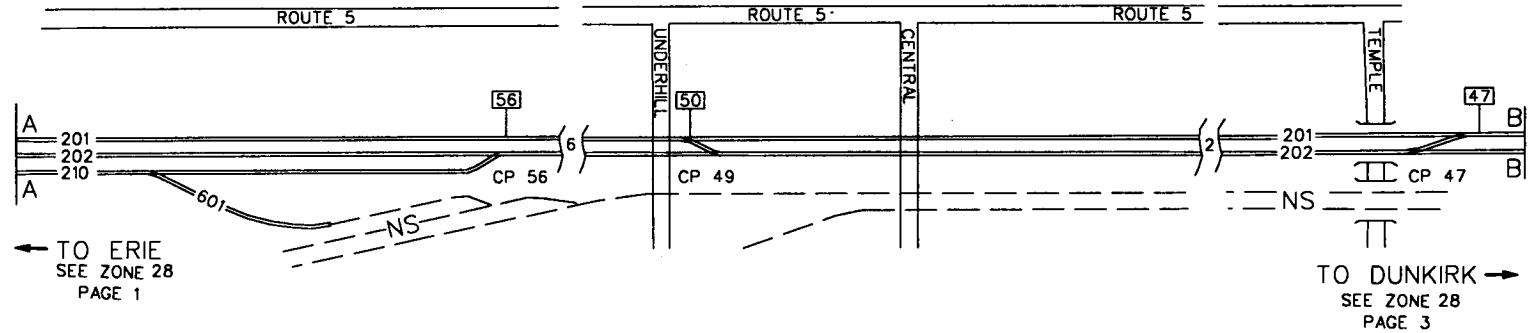

ZONE 28  
 PAGE 2  
 RDBR 30-3500  
 DIVISION ALBANY  
 REV 01-01-95

28 201 00 00 Chicago - Line - Tk.#1  
28 202 00 00 Chicago - Line - Tk.#2  
28 215 00 00 Runner - Tk.#39  
28 720 99 99 Niagara Mohawk Power - Lead  
28 721 99 99 Niagara Mohawk Power - Tk.#1  
28 722 99 99 Niagara Mohawk Power - Tk.#2  
28 723 99 99 Niagara Mohawk Power - Tk.#3  
28 724 99 99 Niagara Mohawk Power - Tk.#4

# DUNKIRK NY

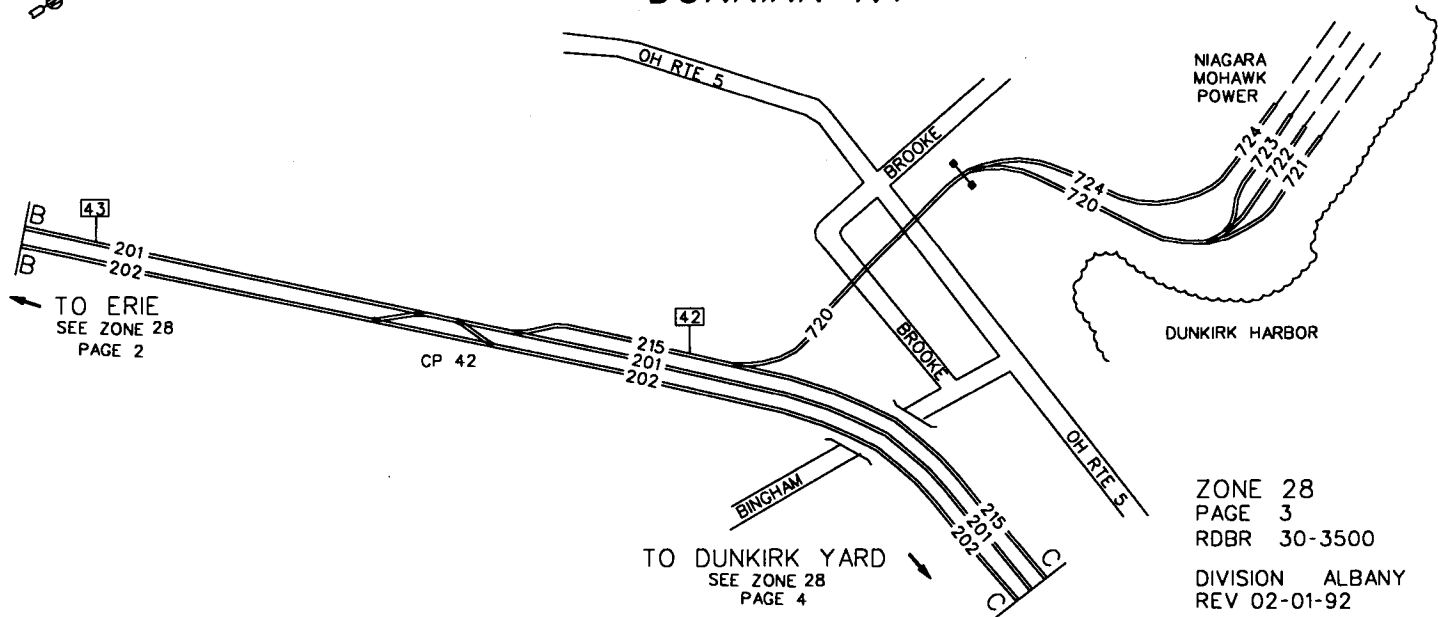

ZONE 28  
PAGE 3  
RDBR 30-3500  
DIVISION ALBANY  
REV 02-01-92

28 201 00 00 Chicago - Line - Tk.#1  
28 202 00 00 Chicago - Line - Tk.#2  
28 215 00 00 Runner - Tk.#39  
28 216 00 00 S. Controlled - Siding - Tk.  
28 217 00 00 N. Controlled - Siding - Tk.  
28 218 00 00 Dunkirk IT  
28 221 00 00 Old - Yd. Lead  
28 222 00 00 Industrial Lead  
28 223 00 00 Former - (EL - I/C - Tk.)  
28 225 00 00 Fredonia - Ind. Tk.  
28 235 00 00 N. Firm - Tk. Lead  
28 611 00 00 Old - Yd. Tk.#1  
28 612 00 00 Old - Yd. Tk.#2  
28 612 01 01 Cargill (Lease 100 Ft.)  
28 614 00 00 Old - Yd. Tk.#4  
28 616 00 00 Old - Yd. Tk.#6  
28 621 00 00 New - Yd. Tk.#1  
28 621 97 97 C B Giardini  
28 622 00 00 New - Yd. Tk.#2  
28 624 00 00 New - Yd. Tk.#4  
28 625 00 00 New - Yd. Tk.#5  
28 626 00 00 New - Yd. Tk.#6  
28 627 00 00 New - Yd. Tk.#7

# DUNKIRK NY

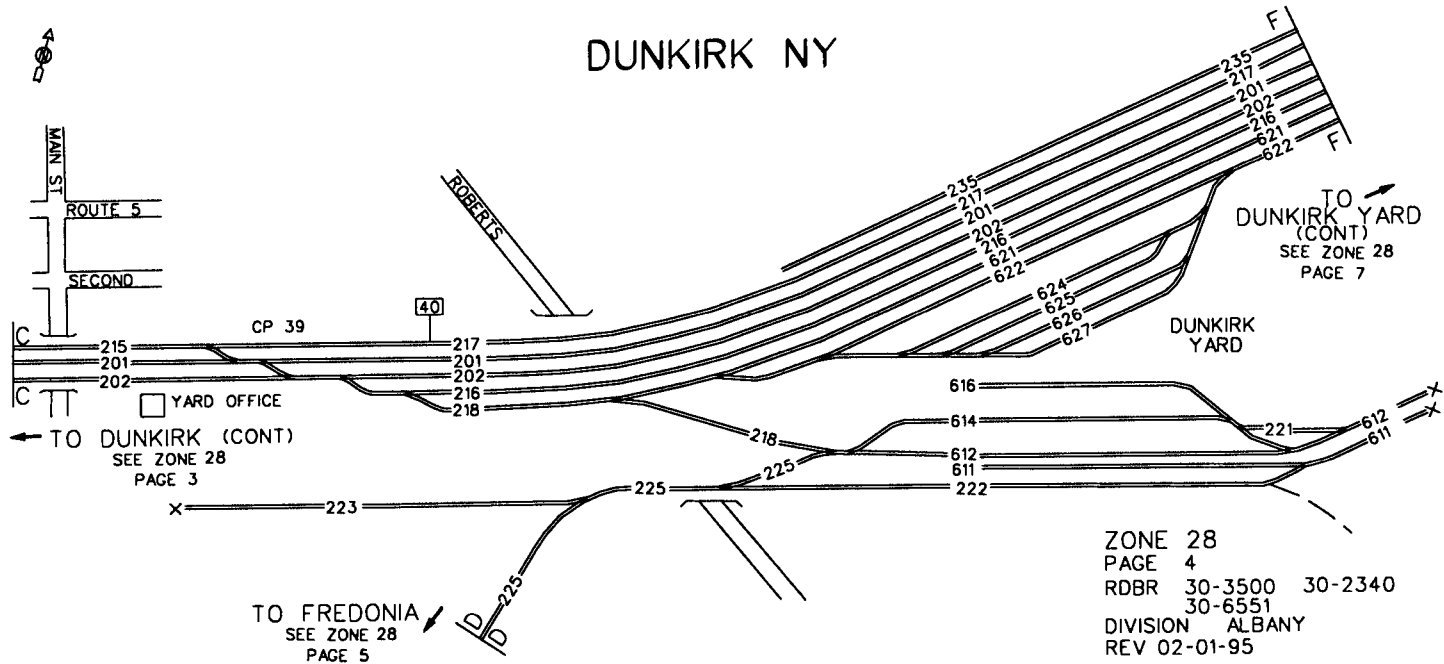

ZONE 28  
PAGE 4  
RDBR 30-3500 30-2340  
30-6551  
DIVISION ALBANY  
REV 02-01-95

ZONE 28

Rev 12/17/96

PAGE 5

|    |     |    |    |                        |
|----|-----|----|----|------------------------|
| 28 | 225 | 00 | 00 | Fredonia - Ind. Tk.    |
| 28 | 634 | 00 | 00 | (NS) - I/C - Tk.       |
| 28 | 741 | 01 | 04 | Lakeside Whse. - Tk.#1 |
| 28 | 742 | 01 | 03 | Lakeside Whse. - Tk.#2 |
| 28 | 743 | 01 | 02 | Lakeside Whse. - Tk.#3 |
| 28 | 744 | 99 | 99 | Lakeside Whse. - Tk.#4 |
| 28 | 749 | 01 | 03 | Vacant                 |
| 28 | 749 | 04 | 06 | Cliffstar              |





ZONE 28

Rev 01/01/95

PAGE 6

28 225 00 00 Fredonia - Ind. Tk.

28 758 01 02 Dunkirk Ice Cream

28 761 01 01 Redwing

28 762 01 03 Redwing

DUNKIRK NY

FREDONIA NY



TO DUNKIRK  
YARD  
SEE ZONE 28  
PAGE 5

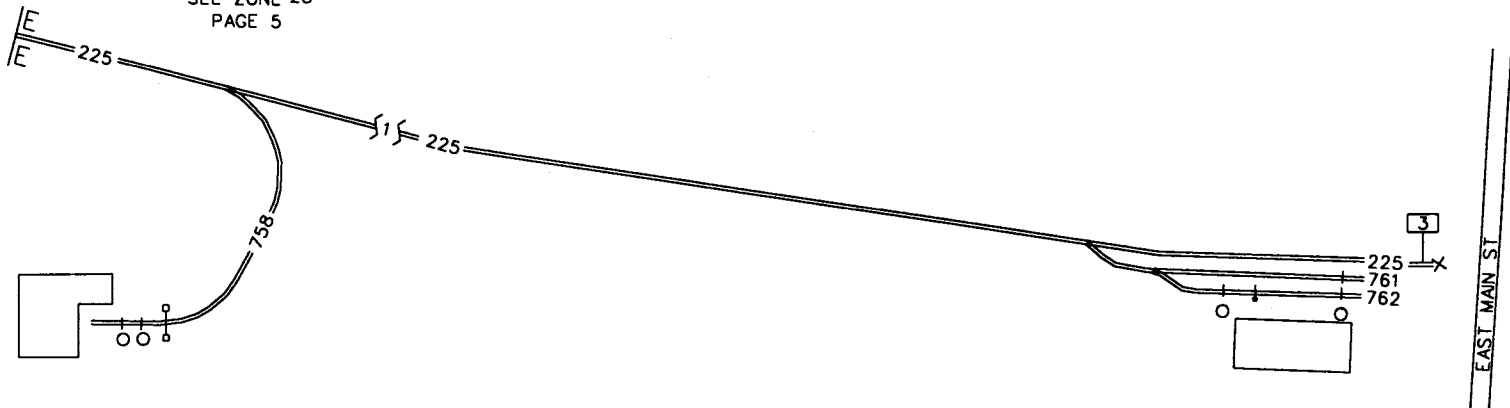

ZONE 28  
PAGE 6  
RDBR 30-2340

DIVISION ALBANY  
REV 01-01-95

ZONE 28

Rev 12/17/96

PAGE 7

28 201 00 00 Chicago - Line - Tk.#1  
28 202 00 00 Chicago - Line - Tk.#2  
28 216 00 00 S. Controlled - Siding - Tk.  
28 217 00 00 N. Controlled - Siding - Tk.  
28 235 00 00 N. Firm - Tk. Lead  
28 612 01 01 Cargill (Lease 100 Ft.)  
28 621 00 00 New - Yd. Tk.#1  
28 621 97 97 C B Giardini  
28 622 00 00 New - Yd. Tk.#2  
28 780 01 03 Lakeside Whse.  
28 782 01 04 Great Lakes Color & Print  
28 783 01 03 Great Lakes Color & Print  
28 791 01 05 Ralston Purina - Tk.#(A)  
28 792 01 08 Ralston Purina - Tk.#(C)  
28 793 01 01 Ralston Purina - Tk.#(D)  
28 794 01 02 Ralston Purina - Tk.#(E)  
28 795 99 99 True Temper

# DUNKIRK NY

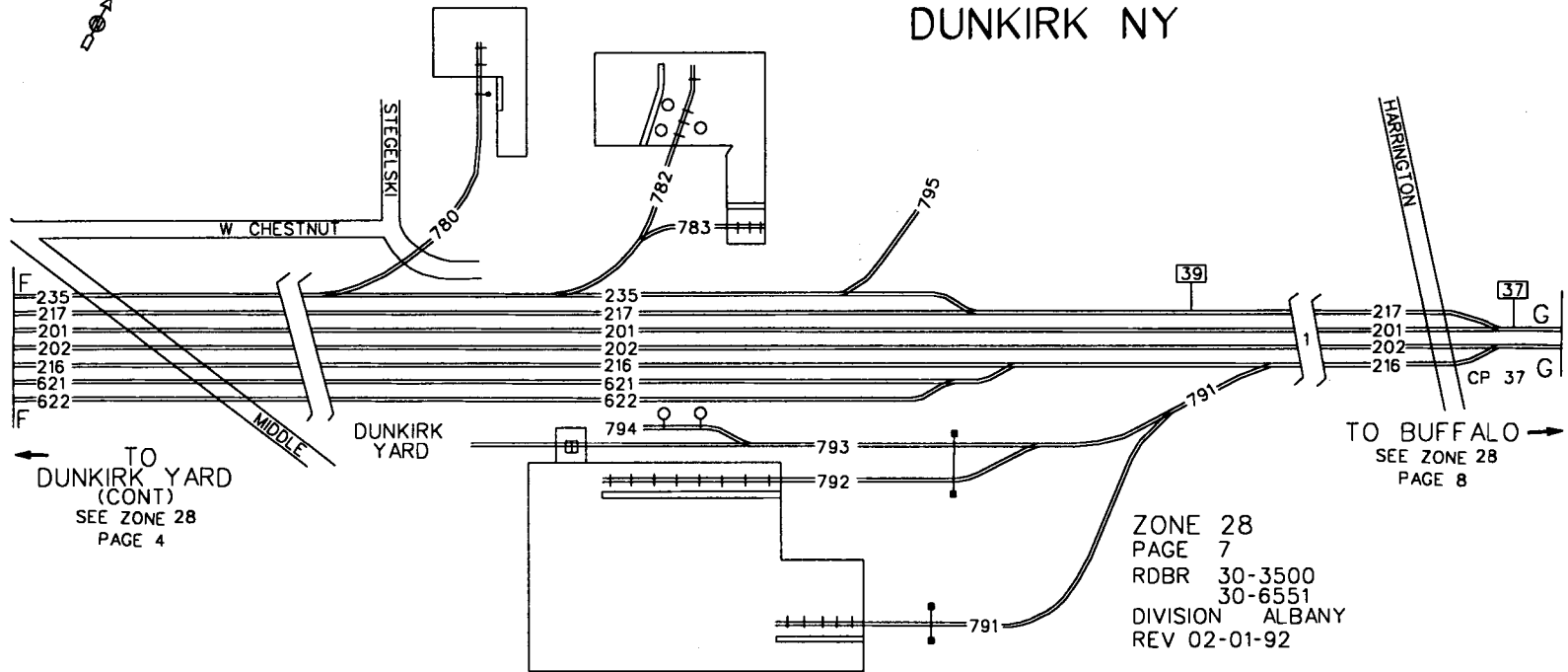

← TO  
DUNKIRK YARD  
(CONT)  
SEE ZONE 28  
PAGE 4

TO BUFFALO →  
SEE ZONE 28  
PAGE 8

ZONE 28  
PAGE 7  
RDBR 30-3500  
30-6551  
DIVISION ALBANY  
REV 02-01-92

ZONE 28

Rev 01/01/95

PAGE 8

28 201 00 00 Chicago - Line - Tk.#1

28 202 00 00 Chicago - Line - Tk.#2

28 240 00 00 Silver Creek - Tk. So. Control - Sdg

28 242 00 00 Silver Creek - Tk. Stub



ZONE 28

Rev 01/01/95

PAGE 9

28 201 00 00 Chicago - Line - Tk.#1

28 202 00 00 Chicago - Line - Tk.#2

28 203 00 00 Chicago - Line - Tk.#3

28 251 00 00 Angola - Tk. Stub





ANGOLA NY

NORTH EVANS NY

BAYVIEW NY

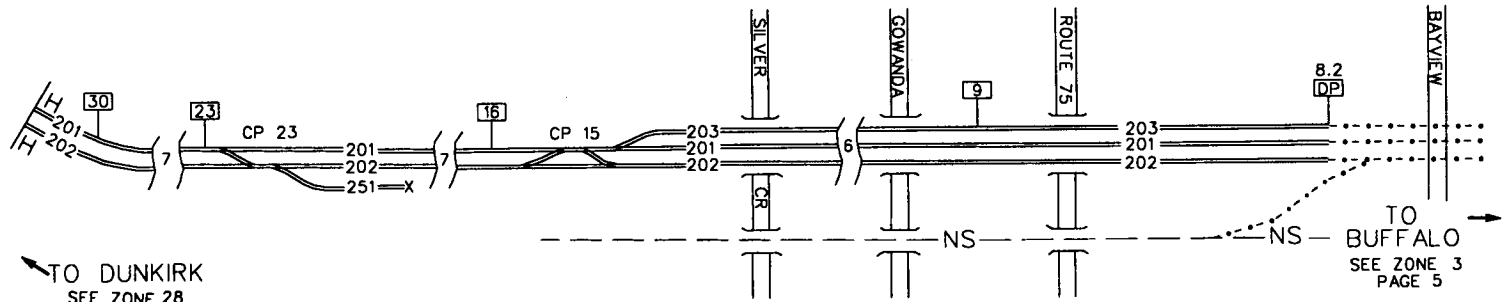

TO DUNKIRK  
 SEE ZONE 28  
 PAGE 8

ZONE 28  
 PAGE 9  
 RDBR 30-3500  
 DIVISION ALBANY  
 REV 02-01-92

TO BUFFALO  
 SEE ZONE 3  
 PAGE 5

